

THIS DRAWING IS UNPUBLISHED. RELEASED FOR PUBLICATION  
 (C) COPYRIGHT BY TYCO ELECTRONICS CORPORATION. ALL RIGHTS RESERVED.

LOC	DIST	REVISIONS					
AA	22	P	LTR	DESCRIPTION	DATE	DWN	APVD
		B1		REV PER ECR-09-004284	16APR2009	TY	SY

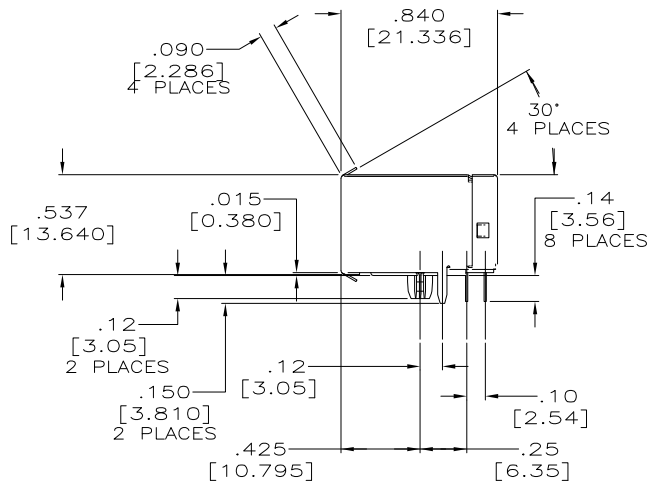

- MATERIAL: HOUSING-PCT POLYESTER, BLACK, IR REFLOW COMPATIBLE, UL 94V-0. TERMINALS-.013[0.33] THICK PHOS BRONZE PLATED WITH .000050[1.27μm] MINIMUM THICK HARD GOLD IN LOCALIZED AREA AND .000150 [3.81μm] MINIMUM THICK MATTE TIN IN SOLDER AREA OVER .000050[1.27μm] MINIMUM THICK NICKEL UNDERPLATE. SHIELDS-.010[0.254] THICK COPPER ALLOY PLATED WITH .000050[1.27μm] MINIMUM NICKEL AND .000080 [2.03 μm] MINIMUM HOT TIN DIP ON PCB GROUND TABS.
- JACK CAVITY CONFORMS TO FCC RULES AND REGULATIONS, PART 68 SUBPART F.
- ALL DIMENSIONS SHOWN ARE NOMINAL UNLESS OTHERWISE SPECIFIED.
- ALL DIMENSIONS SHOWN IN BRACKETS [ ] ARE IN MILLIMETERS.
- SHORT IS REMOVED BY INSERTION OF MODULAR PLUG.
- USE #30 DRILL BIT OR 3.25mm DRILL BIT WHEN PRODUCING THESE PCB HOLES.

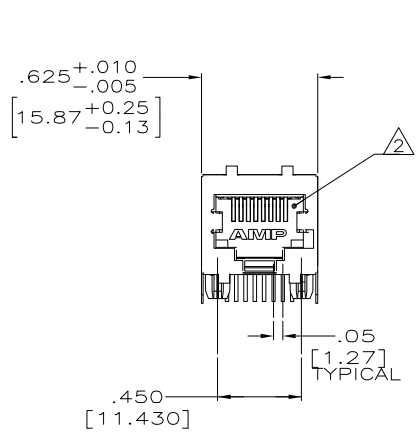
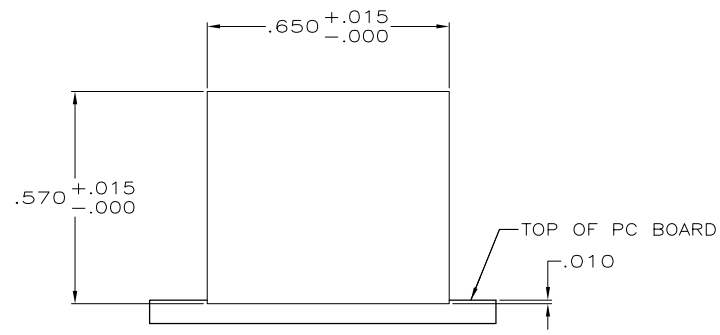
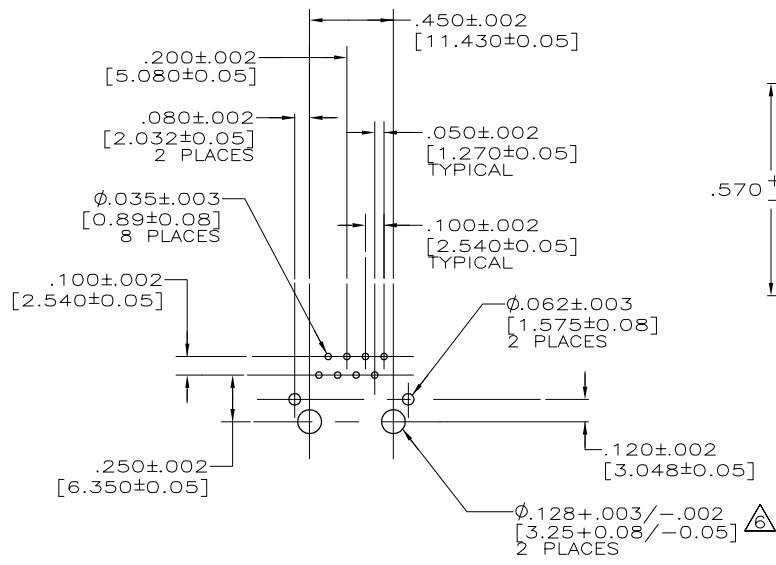

SUGGESTED PANEL CUTOUT  
SCALE 4:1



SHORTING FEATURE

SUGGESTED PC BOARD LAYOUT  
COMPONENT SIDE

5557791-1  
PART NUMBER

THIS DRAWING IS A CONTROLLED DOCUMENT.		DWN V. SLACK/L.A. MAYER 25MAY2005	Tyco Electronics Corporation Harrisburg, Pa 17105-3608	
DIMENSIONS: INCHES		CHK J. WESTMAN 25MAY2005	APVD S. FLICKINGER 25MAY2005	
TOLERANCES UNLESS OTHERWISE SPECIFIED:		NAME		RESTRICTED TO
0 PLC ± -	1 PLC ± -	PRODUCT SPEC		SIZE
2 PLC ± .01[0.254]	3 PLC ± .005[0.127]	108-1163		CAGE CODE
4 PLC ± -	ANGLES ± -	APPLICATION SPEC		DRAWING NO
MATERIAL		114-2048		RESTRICTED TO
SEE NOTE 1		WEIGHT		SCALE
SEE NOTE 1		A2 00779 C=5557791		SHEET
		CUSTOMER DRAWING		1 OF 1
				REV B1