



Tsi350A™ PCI-to-PCI Bridge Product Brief

Device Overview

The IDT Tsi350A is a PCI-to-PCI bridge that is fully compliant with *PCI Local Bus Specification, Revision 2.3*. The Tsi350A has sufficient clock and arbitration pins to support nine PCI bus master devices directly on its secondary interface.

The Tsi350A allows the two PCI buses to operate concurrently. This means that a master and a target on the same PCI bus can communicate while the other PCI bus is busy. This traffic isolation may increase system performance in applications such as multimedia.

The Tsi350A makes it possible to extend a system's load capability limit beyond that of a single PCI bus by allowing motherboard designers to add more PCI devices or more PCI option card slots than a single PCI bus can support.

The Tsi350A has two identical PCI Interfaces that each handle PCI transactions for its respective bus, and, depending on the type of transaction, can act as either a bus master or a bus slave. These interfaces transfer data and control information flowing to and from the blocks shown below.

Block Diagram

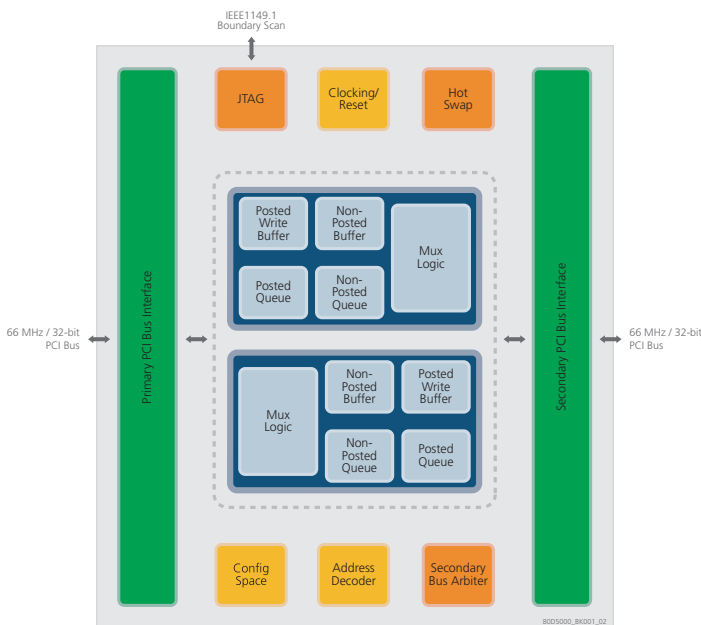

Features

- Industry-standard 32-bit, 66-MHz PCI bridge
- Fully *PCI Local Bus Specification, Revision 2.3* compliant
- Supports up to nine PCI bus masters on the secondary interface
- Ten independent secondary clock outputs to the secondary slots
- Primary and secondary interfaces can be operated using asynchronous clocks
- Secondary clock can either be derived from the input primary clock or supplied by an external clock source
- Secondary clocks can be masked through the GPIO interface during power up
- Supports four independent delayed transactions in each direction
- Supports up to nine secondary requests and grants
- External arbiter support on the secondary bus
- Supports CompactPCI Hot Swap functionality
- CI Power management with D3Hot support with option to disable clocks during D3Hot state
- Supports Bus Locking mechanism
- VGA/Palette memory and I/O decoding options
- Optional non-posted entry flush upon posted writes traveling the same direction
- Compatible with existing solutions from Intel, TI, PLX, and Pericom

Physical

- 208 PQFP and 256 PBGA packages
- 3.3 V I/O, 5 V tolerant

Benefits

- Extend PCI load capability
- Straightforward system design through the Tsi350A's highly configurable features

Typical Applications

- Industrial PC's (IPC) backplanes
- Video capture cards
- Embedded video recorders (EVRs)
- Multi-function printers
- Storage host bus adapters (HBAs)
- Network interface cards (NICs)
- Firewall and security gateways
- Printers, graphics and imaging systems

Option card designers can use Tsi350A to implement multiple-device PCI option cards. Without a PCI-to-PCI bridge, PCI loading rules would limit option cards to one device. The *PCI Local Bus Specification* loading rules limit PCI option cards to a single connection per PCI signal in the option card connector. The Tsi350A overcomes this restriction by providing, on the option card, an independent PCI bus to which up to nine devices can be attached.

The following figure shows how the Tsi350A enables the design of a multi-component option card or expand existing PCI buses.

Application Diagram

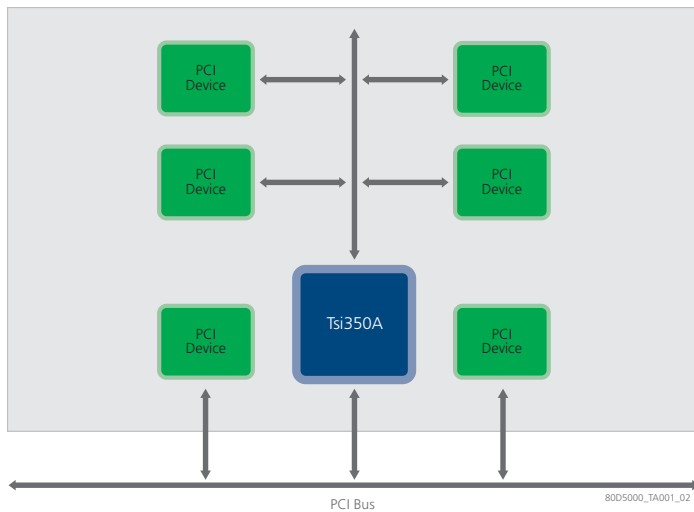

NOT AN OFFER FOR SALE

The information presented herein is subject to a Non-Disclosure Agreement and is for planning purposes only. Nothing contained in this presentation, whether verbal or written, is intended as, or shall have the effect of, a sale or an offer for sale that creates a contractual power of acceptance.



CORPORATE HEADQUARTERS
 6024 Silver Creek Valley Road
 San Jose, CA 95138

for SALES:
 800-345-7015 or 408-284-8200
 fax: 408-284-2775
 www.idt.com

for Tech Support:
 email: ssdhelp@idt.com
 phone: 408-284-8208
 document: 80D5000_FB001_07