

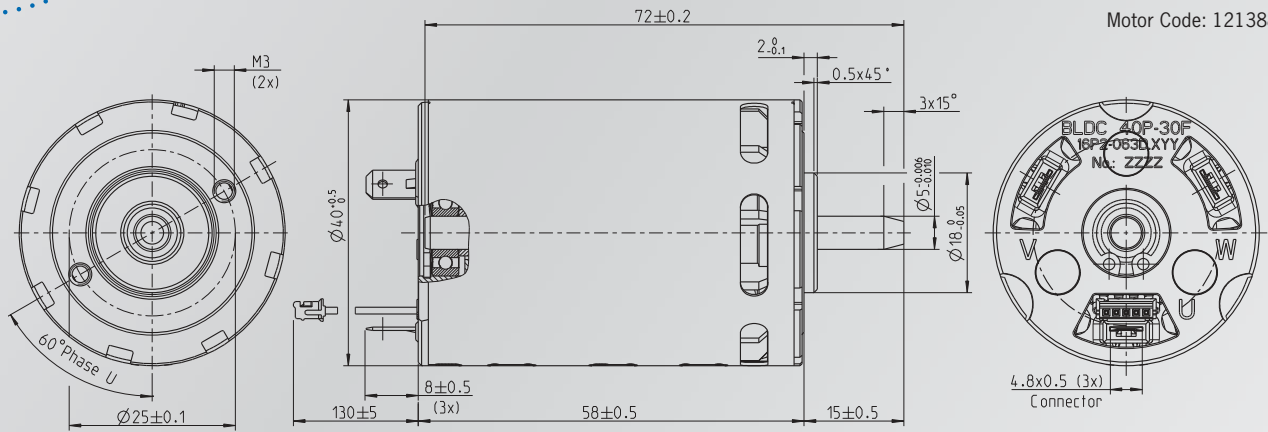

# BLDC 40P30F

11P2.071D

Rated Voltage	No Load Speed	Rated Speed	Cont. Power	Rated Torque	Current at rated Speed	Efficiency at Duty Point
[ V ]	[ rpm ]	[ rpm ]	[ W ]	[ mNm ]	[ A ]	[ % ]
12	18.545	12.655	241	182	26,3	82



## General informations

- **Class of protection:** IP20
- **Mounting position:** free
- **Duty cycle:** up to 100 %
- **Bearing system:** Ball Bearings
- **Torque Constant:** 5,8 mNm/A
- **Weight:** 0,285 kg
- **Rotor Inertia:** 40 gcm<sup>2</sup>
- **Oper. Temp. Range:** -20 °C to +45 °C
- **Max. Temp. Rise:** 70 K
- **Direction of Rotation:** CW / CCW
- **Class of Insulation:** H
- **Shaft Material:** Steel, not hardened
- **Number of Poles:** 8

## Options

- **Integrated Drive Electro.:** Yes
- **Planetary Gearbox:** Yes
- **Sensorless Operation:** Yes
- **Shaft hardened (Surface):** Yes

## Features

- High power-to-volume ratio
- High efficiency at duty point
- Extremely reliable

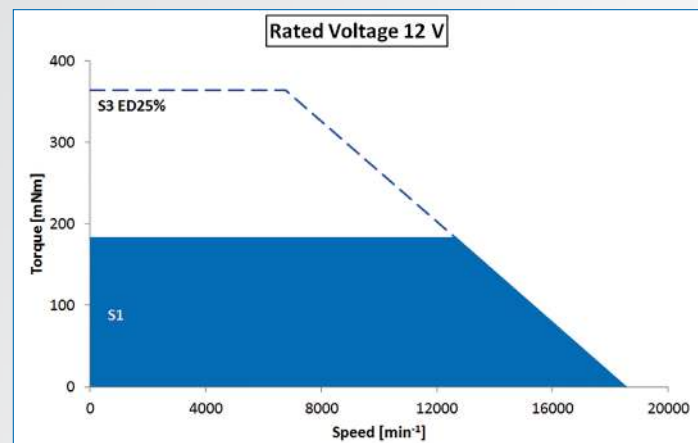

# PM DM

Minebea Group of Companies  
 Minebea-Weg 1  
 78052 Villingen-Schwenningen  
 GERMANY  
 www.pmdm.de  
 Phone: +49 (0)7721 997-100  
 E-Mail: sales@pmdm.de

**Minebea**  
 Passion to Exceed Precision

# Sample Request Form Brushless DC

Customer		Contact	
Adress		Telephone	
Enduser		Email	
Project No.		Project Name	
Customer Part No.		NMB Part No.	
<b>Commercial Information</b>			
Sample Qty.		Competitor	
Sample Price		Part No.	
Annual Qty.		Application	
Target Price		Application Details	
Time Schedule			
<b>Technical Specification</b>			
Drive Condition	Drive	Torque	Rated Torque
	Source		Max. Torque
Voltage	Rated Voltage	Life	No. of Cycles per Hour
	Operating Voltage		Duty Cycle
Speed	No Load Speed	Shaft Rotation	CW
	Rated Speed		CCw
Current	Rated Current		Both
	Stall Current	Ambient Temp. Range	
<b>Mechanical Dimensions</b>			
Motor Diameter		Shaft Diameter	
Motor Length		Shaft Length	
<b>Special Requirements</b>			