

REVISIONS					
P	LTR	DESCRIPTION	DATE	DWN	APVD
	K1	ECN-22-171534	30AUG2022	RK	JO

NOTE:  
FINISH

- △1 .000030 GOLD OVER NICKEL SELECTIVE ON CONTACT AREA.
- △2 .000015 GOLD OVER .000050 NICKEL SELECTIVE ON CONTACT AREA.
- △3 GOLD FLASH OR TIN PLATE OVER NICKEL ON SOLDER TAB.
- △4 GOLD PLATING THICKNESS TO BE MEASURED WITH A MASK HAVING A .012 APERTURE LOCATED .156 FROM THE NOSE OF CONTACT
- △5 .000100/.000200 BRIGHT TIN LEAD PLATING ALL OVER, NICKEL UNDER PLATE ALL OVER.
- △6 GOLD FLASH OR MATTE TIN PLATE OVER NICKEL ON SOLDER TAB.

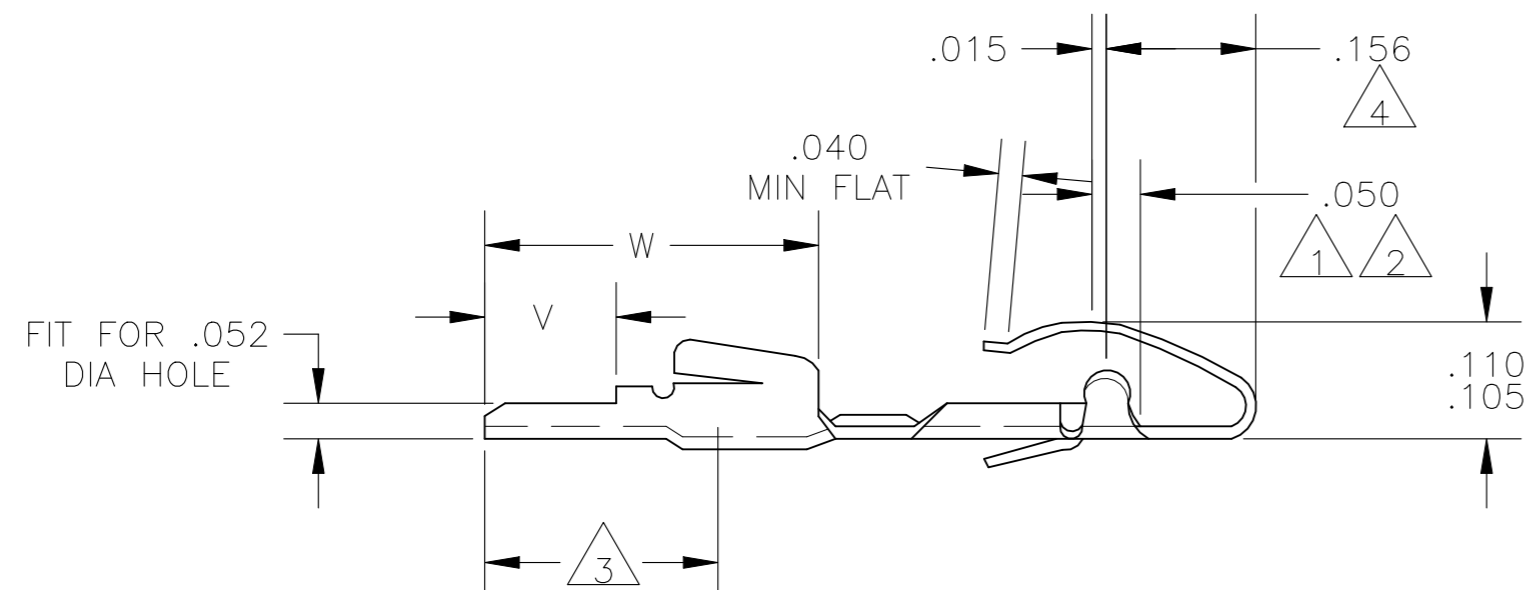
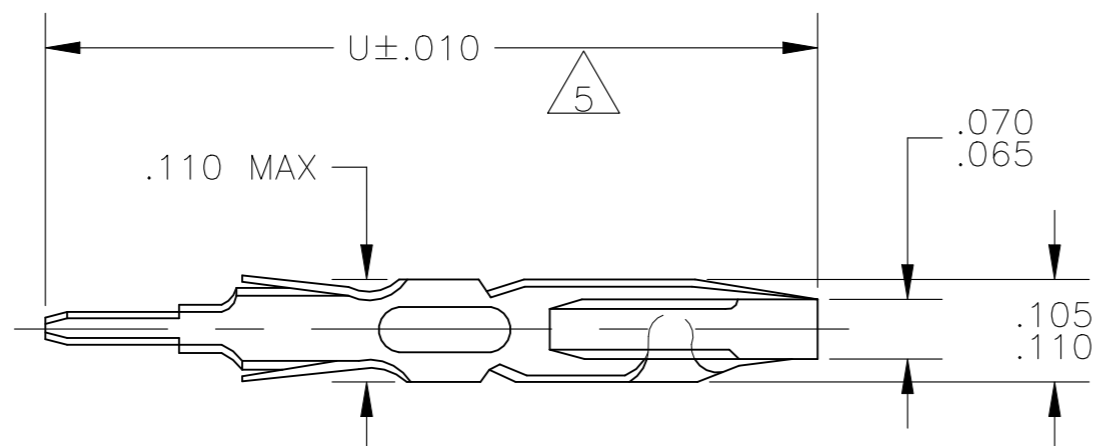

	1/16	△2 △6	.345	.120	.810	5-583294-2
	1/16	△1 △6	.345	.120	.810	5-583294-1
OBSOLETE	1/16	△5	.345	.120	.810	583294-8
OBSOLETE	3/32	△2	.375	.150	.840	583294-4
OBSOLETE	3/32	△1	.375	.150	.840	583294-3
OBSOLETE	1/16	△2	.345	.120	.810	583294-2
	1/16	△1	.345	.120	.810	583294-1
	BOARD THK	FINISH	W	V	U	PART NO.

THIS DRAWING IS A CONTROLLED DOCUMENT.		DWN	26SEP67	<b>TE</b> TE Connectivity	
		CHK	14SEP67		
DIMENSIONS: INCHES		TOLERANCES UNLESS OTHERWISE SPECIFIED:		NAME	
		0 PLC ± -		PRODUCT SPEC	
		1 PLC ± -		APPLICATION SPEC	
		2 PLC ± -		WEIGHT	
		3 PLC ± -		SCALE	
4 PLC ± -		ANGLES ± -		SIZE	
MATERIAL PHOSPHOR BRONZE		FINISH SEE TABLE		CAGE CODE	
				DRAWING NO	
				RESTRICTED TO	
				A2 00779 C=583294	
		CUSTOMER DRAWING		SHEET 1 OF 1	
				REV K1	