

PART NUMBER	REV	FIRST USED	POWER UNIT	FEED TYPE
1852690-1	A	122500-1	LEADMAKER & BENCH MODEL G	POST FEED
1852690-2	A	565435-5	BENCH MODEL K	POST FEED
7-1852690-7	A	-	SPARE PARTS	-

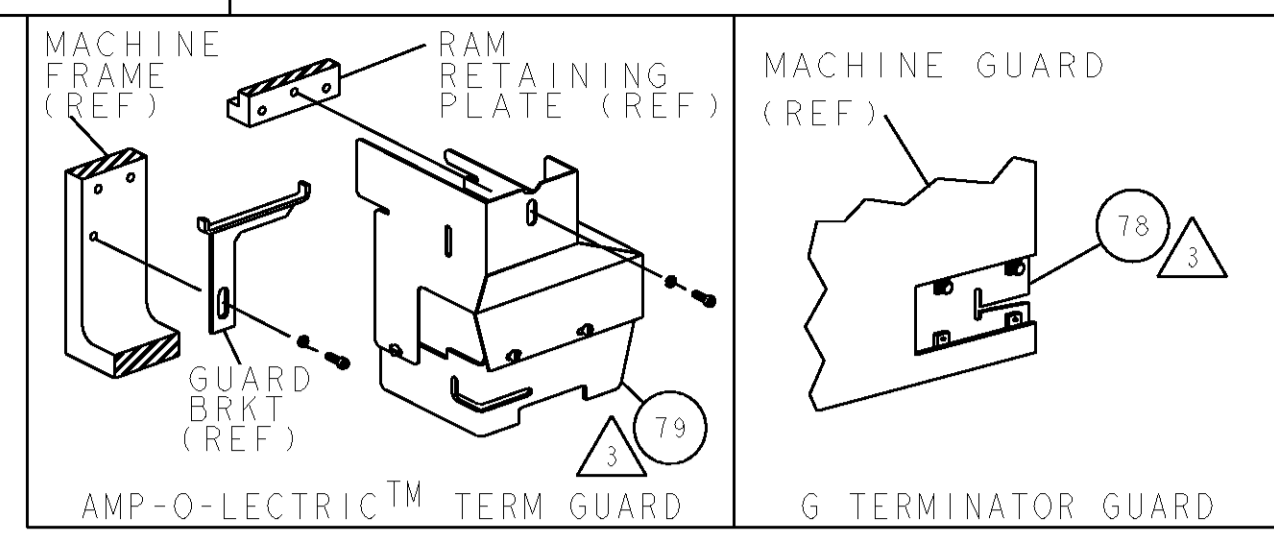

TERMINAL NAME: POINT TERMINAL		INARCA		INARCA TERMINAL - TE CRIMP SPECS	
1949677-1	0010278001	PAD LTR			
1949677-2	0010278201			CRIMP HEIGHT	WIRE SIZE
1949677-3	0110278001	A		1.30±0.05mm [.051±.002]	1mm2
1949677-4	0110278201	B		1.20±0.05mm [.047±.002]	0.75mm2
-	-	C		1.16±0.05mm [.046±.002]	19AWG BRAIDED
-	-	D		1.09±0.05mm [.043±.002]	0.5mm2
-	-			CRIMP	SIZE
-	-			WIRE	2.03mm [.080]
-	-			INSUL	3.05mm [.120]
				TYPE	RANGE
				F	0.5-1mm2
				F	∅ 1.9-2.5mm
WIRE STRIP LENGTH	TERM APPL SPEC	FEED	APPL INSTRUCTIONS	SET UP GAGE	
5.9 - 6.7mm	NONE	11.2mm	408-8039	458638-1	

- △ RECOMMENDED SPARE PARTS
- △ GREASE LIGHTLY
- △ GUARD MUST BE IN PLACE WHEN OPERATING APPLICATOR IN A BENCH MACHINE
- △ CUSTOMER SUPPLIED WIRE.

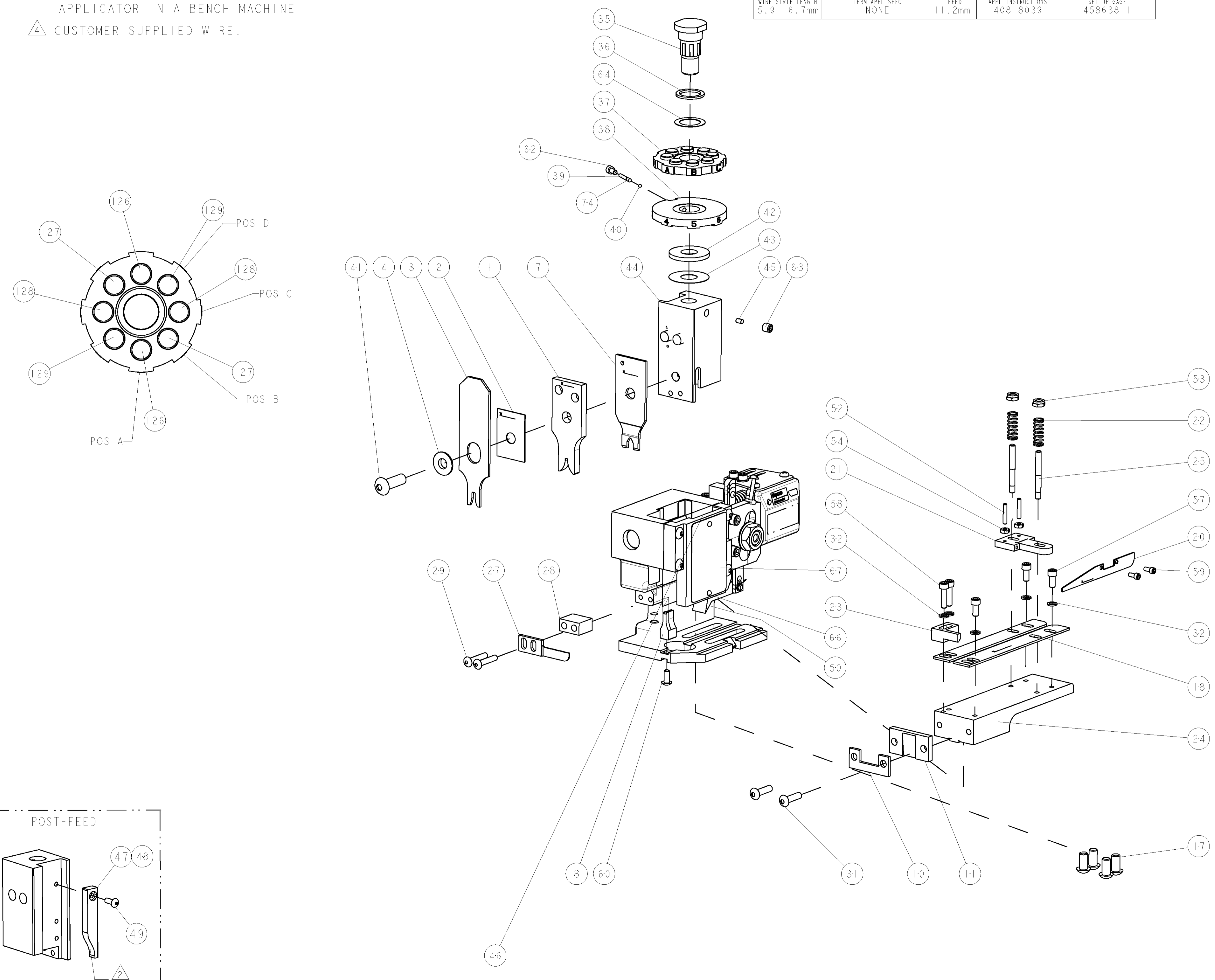

LOC	DIST	REVISIONS			
A	66	P LTR	DESCRIPTION	DATE	DWN
		A	RELEASED	03JUN2008	RK

-	2	2	-	6-354779-4	PIN, WIRE DISC, .3310	129
-	2	2	-	5-354779-8	PIN, WIRE DISC, .3280	128
-	2	2	-	5-354779-3	PIN, WIRE DISC, .3255	127
-	2	2	-	4-354779-2	PIN, WIRE DISC, .3200	126
△	REF	-	-	455745-1	GUARD WINDOW	79
△	-	REF	-	679532-1	INSERT, GUARD	78
-	1	1	-	690603-1	SPRING ASSIST AMP-O-MATOR APPLICATOR	74
-	1	1	-	217238-1	GENERAL INSTRUCTION PKG	72
-	1	1	-	4088039	EF APPL INST 408-8039	71
-	1	1	-	461264-1	PLATE, IDENTIFICATION	67
-	2	2	-	21017-2	SCREW, DRIVE	66
-	1	1	-	986950-1	WASHER, FLAT PRECISION	64
-	1	1	-	21009-2	SCR, SET, SELF LOCKING 1/4-20 X .250	63
-	1	1	-	23030-1	SCR, SKT HD CAP 6-32 X .25	62
-	1	1	-	22733-8	SCR, BHSC, SELF-LOCKING, 8-32 X .375	60
-	2	2	-	1-21000-3	SCR, SKT HD CAP 4-40 X .250	59
-	2	2	-	2-21000-8	SCR, SKT HD CAP 8-32 X .625	58
-	3	3	-	2-21000-6	SCR, SKT HD CAP 8-32 X .375	57
-	2	2	-	21018-4	NUT, HEX, REG 4-40	54
-	2	2	-	21022-2	NUT, LOCK, HEX, TORQUE, 8-32	53
-	2	2	-	2-21006-6	SCR, SET, CUP POINT 4-40 X .625	52
-	1	1	-	240635-1	FINGER, FEED	50
-	1	1	-	1-21002-7	SCR, BTN SKT CAP 6-32 X .375	49
-	1	1	-	690501-3	CAM, POST FEED, 1 1/8	48
-	-	1	-	690501-4	CAM, POST FEED, 1 5/8	47
-	1	1	-	1-458980-0	SUB ASSY, APPLICATOR FRAME	46
-	1	1	-	690191-1	PLUG, NYLON	45
-	1	1	-	455674-5	RAM	44
-	1	1	-	690125-1	SHIM SUB-ASSY	43
-	1	1	-	690124-1	WASHER, RAM (.115)	42
-	1	1	-	7-21002-9	SCR, BTN SKT HD CAP 5/16-24 X 1.00	41
-	1	1	-	23241-6	BALL, STEEL	40
-	1	1	-	690170-1	SPRING, COMPRESSION	39
-	1	1	-	690142-1	DISC, INSULATION	38
-	1	1	-	354777-1	WIRE DISC, ASSEMBLY	37
-	1	1	-	22480-5	SPRING, COMPRESSION	36
-	1	1	-	690212-1	POST, RAM	35
-	5	5	-	21024-4	WASHER, SPRG LOCK, REG NO 8	32
-	2	2	-	2-21002-9	SCR, BTN SKT HD CAP 10-32 X .750	31
-	2	2	-	9-21002-6	SCR, BTN SKT HD CAP 8-32 X .875	29
-	1	1	-	2-690451-7	SPACER, STRIPPER	28
-	1	1	-	240639-2	STRIPPER (MACHINING)	27
-	2	2	-	22354-8	STUD, THREADED	25
-	1	1	-	455678-3	PLATE, STRIP GUIDE	24
-	1	1	-	240825-1	PLATE, STRIP HOLD DOWN	23
-	2	2	-	2-22281-6	SPRING, COMPRESSION	22
-	1	1	-	464451-1	ARM, STOCK DRAG	21
-	1	1	-	464452-1	DRAG, STOCK	20
-	2	2	-	454204-1	GUIDE, LOWER STRIP	18
-	4	4	-	3-21002-3	SCR, BTN SKT HD CAP 1/4-20 X .500	17
△	1	1	-	240644-5	PLATE, REAR SHEAR	11
△	1	1	-	1633668-1	SPACER, SHEAR PLATE	10
△	1	1	-	1633667-1	ANVIL, COMBINATION	8
△	1	1	-	2-459722-0	BLADE, SHEAR	7
-	-	-	-	-	-	6
-	-	-	-	-	-	5
-	1	1	-	1-238009-2	BLOCK, FL CRIMPER SPACER	4
△	1	1	-	7-456134-3	CRIMPER, INSULATION F PREMIUM	3
△	1	1	-	455888-5	SPACER, CRIMPER	2
△	1	1	-	1633664-2	CRIMPER, WIRE	1

ITEM NO	U/M	PART NO	DESCRIPTION	ITEM NO
-77	-2	-1	U/M PART NO	

DIMENSIONS: INCHES 0 PLC ±.01 1 PLC ±.01 2 PLC ±.01 3 PLC ±.001 4 PLC ±.0001 ANGLES ±.001		TOLERANCES UNLESS OTHERWISE SPECIFIED: ±.01 ±.01 ±.001 ±.0001	
MATERIAL		FINISH	
WEIGHT		SCALE 3:5	
CUSTOMER DRAWING		SHEET 1 OF 1	

DWN	R. KNEPPER	01MAY2008	
CHK	T. ELBIN	03JUN2008	
APVD	N. DEMING	03JUN2008	
NAME		END FEED HDM APPLICATOR	
PRODUCT SPEC		-	
APPLICATION SPEC		-	
SIZE		A1	
CAGE CODE		00779	
DRAWING NO		1852690	
REV		A	