

REV	ECN	APP'D
-	4158	

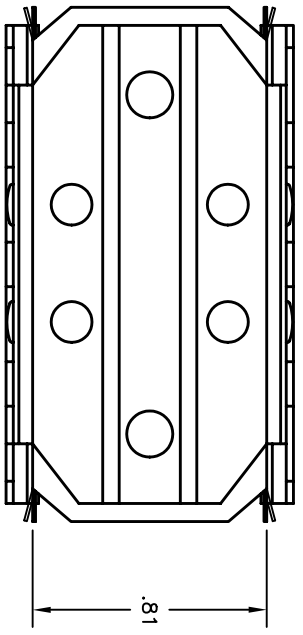
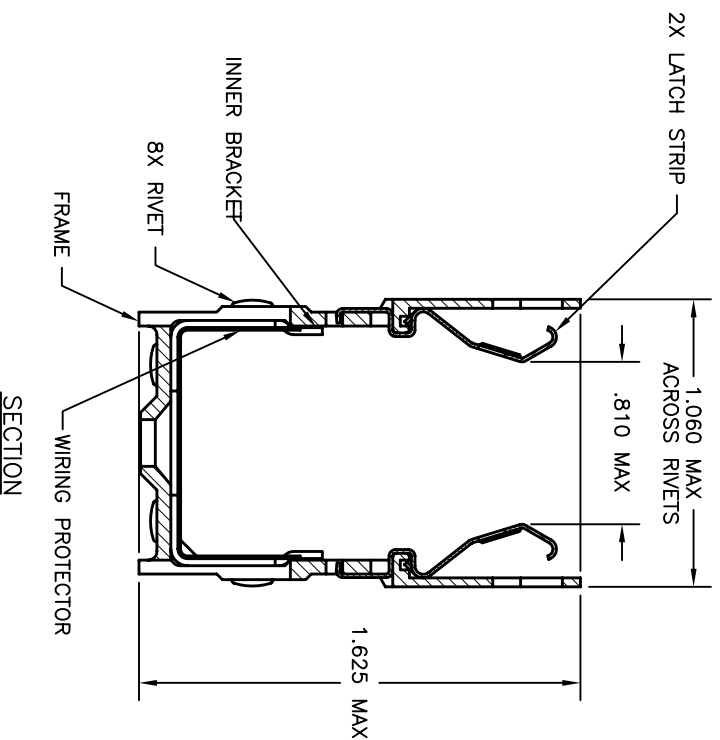
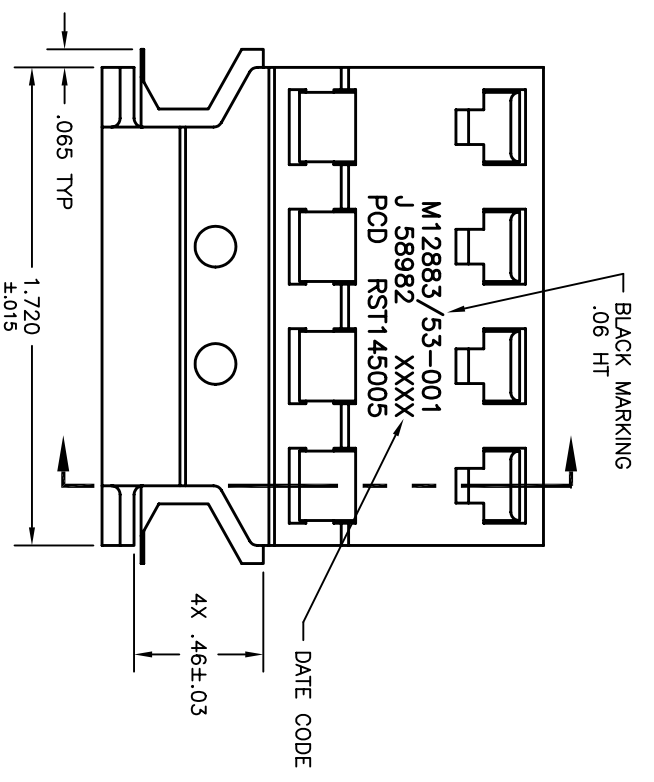

- NOTES:
- MATERIALS:
 OUTER TRACK: ALUMINUM ALLOY PER QQ-A-225. CHEMICAL COATING PER MIL-C-5541, CLASS 3
 INNER BRACKETS AND RIVETS: STAINLESS STEEL PER QQ-S-766, PASSIVATED
 LATCH: BERYLLIUM COPPER #172 PER QQ-C-535, BRIGHT FINISH
 WIRING PROTECTOR: ARAMID PAPER PER MIL-I-24202
 PERFORMANCE SPECIFICATIONS:
 OPERATING TEMPERATURE: -65 TO 125 DEG C
 FOR USE WITH PCD SOCKET PART NO'S RSE116175, RSE116185, AND RSE116195

DIMENSIONS	ANSI Y14.5M	TOLERANCES	.XX ±.01	PROJECTION						
	UNITS: INCHES	.XXX ±.005	ANGLES ±2°							
ACAD FILE	ORIGINAL	THIS DOCUMENT CONTAINS PROPRIETARY INFORMATION WHICH IS THE CONFIDENTIAL PROPERTY OF PCD, INC. PEABODY, MA, USA		CHKD	SPECIFICATION DRAWING		TITLE	MOUNTING TRACK RELAY SOCKET M12883/53-001	REV	-
ENGR	MEL	10/25/00	APPD	SIZE	DWG NO.		RST145005	SCALE:	NONE	SHEET
CODE:	58982	SCALE:	NONE	SHEET	1 OF 1					