

THIS DRAWING IS UNPUBLISHED. RELEASED FOR PUBLICATION, 19 .
 © COPYRIGHT 19 BY AMP INCORPORATED. ALL INTERNATIONAL RIGHTS RESERVED.

LOC	DIST	P	F	ZONE	LTR	DESCRIPTION	DATE	APPD
G	14				G	REVISED PER 0L20-0148-96	10DEC96	OKS MJ5

METRIC
 DIMENSIONS LISTED IN mm [INCHES]

AMP WIRE RANGE	UL E13288 Listed
22-16 AWG SOLID OR STRANDED	NOT APPLICABLE
SR LR7189 Certified	MILITARY P/N AND CLASS
NOT APPLICABLE	NOT APPLICABLE

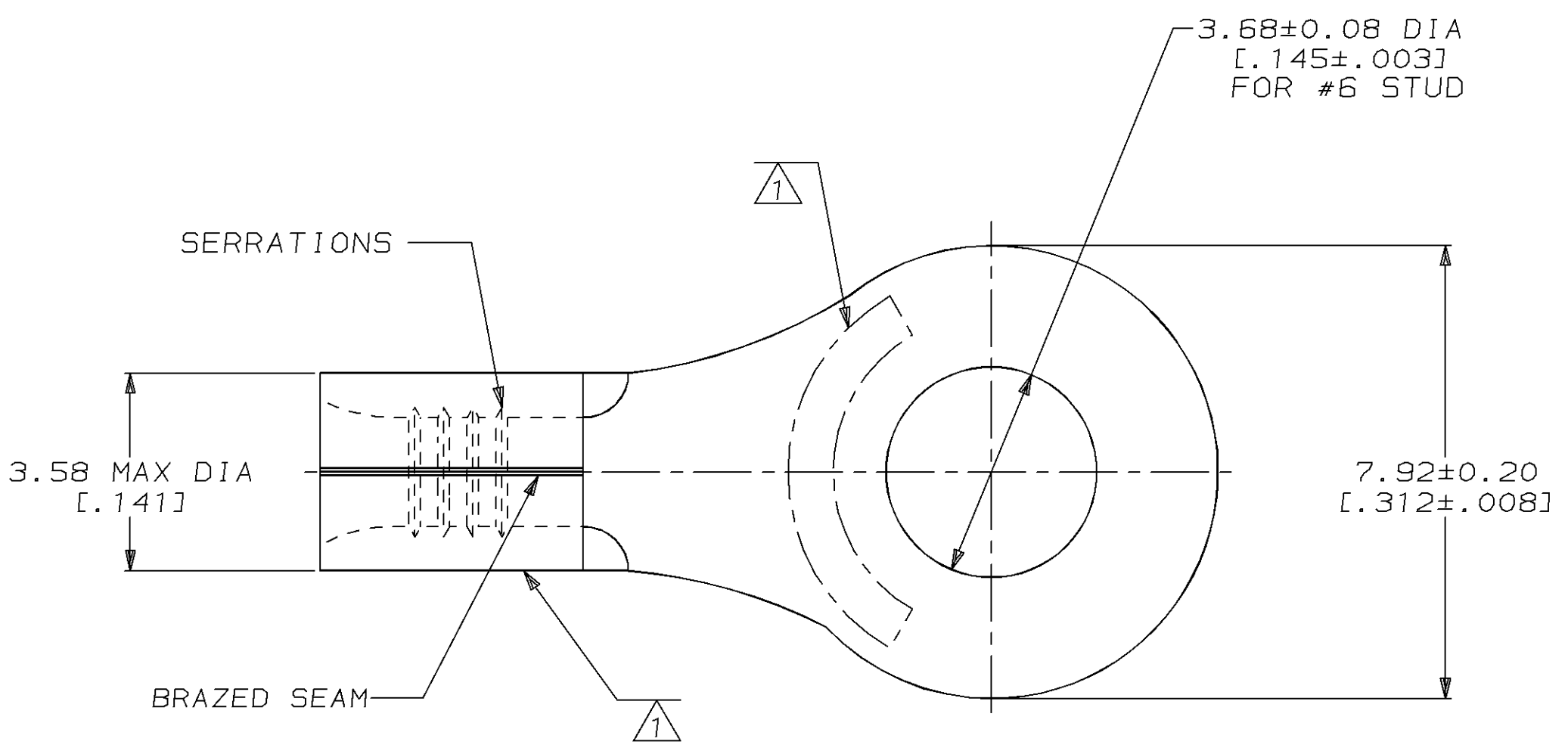

- ① STAMP AMP 22-18 APPROX AS SHOWN
 22-16 TERMINALS ARE STAMPED 22-18 IN
 ACCORDANCE WITH MILITARY SPECIFICATION
 MIL-T-7928; COMMERCIAL WIRE RANGE IS 22-16
- ② WIRE BARREL COLOR CODED ORANGE
 TO DENOTE NICKEL MATERIAL

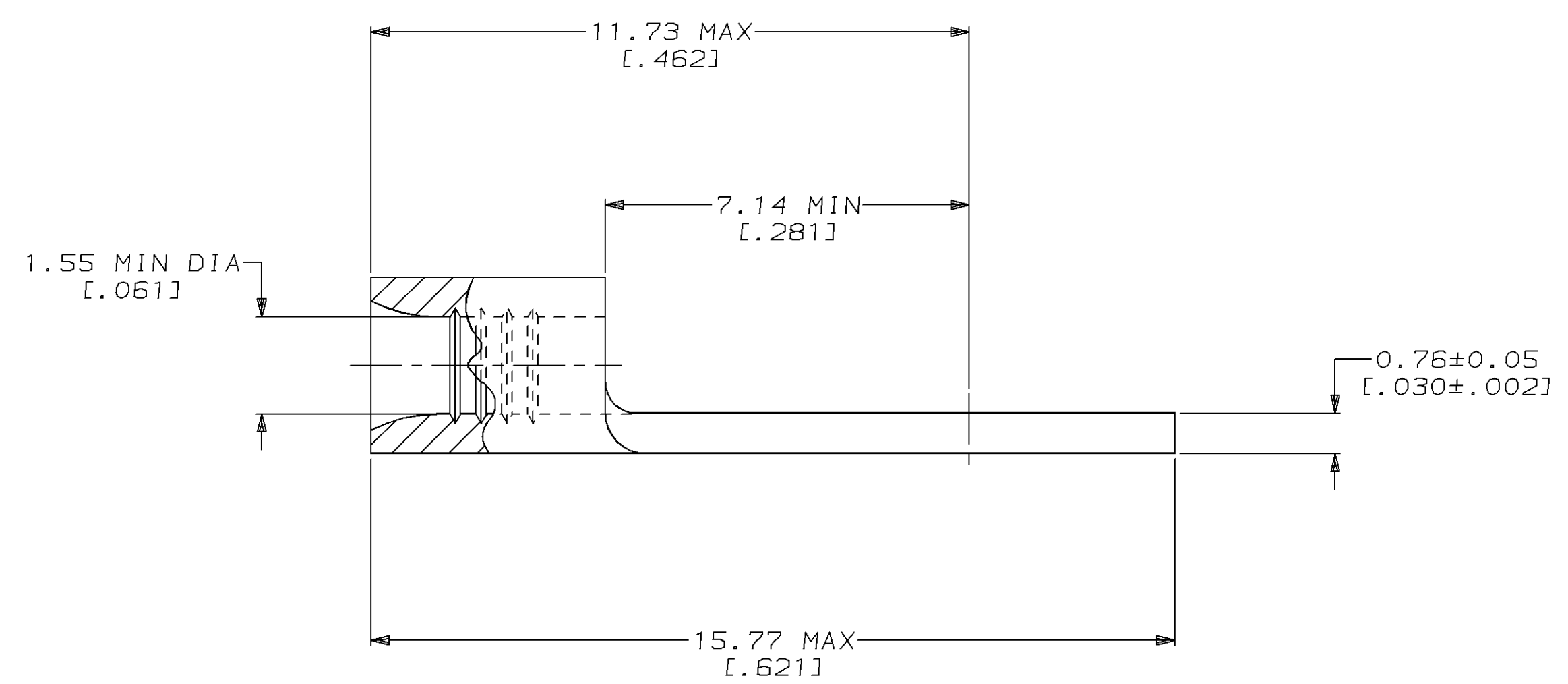

AMP INCORPORATED CUSTOMER SERVICE SYSTEMS		MAX RECOMMENDED OPERATING TEMPERATURE: 649°C MAX	DO NOT SCALE PRINT. UNLESS SPECIFIED DIMENSIONS IN mm [INCHES] TOLERANCES ON: 2 PLC DEC ± - 3 PLC DEC ± - ANGLES ± -	DR 4-15-93 TA BRINKMAN	322872 PART NO			
FOR ADDITIONAL PRODUCT INFORMATION OR COPIES OF DRAWINGS AND TECHNICAL DOCUMENTS	PRODUCT INFORMATION CENTER 1-800-522-6752	VOLTAGE RATING: NOT APPLICABLE	MATERIAL NICKEL PER ASTM B-162 ANNEALED	CHK 4-15-93 DA PATTERSON	AMP AMP Incorporated Harrisburg, PA 17105-3608			
FOR APPLICATION TOOLING INFORMATION	TOOLING ASSISTANCE CENTER 1-800-722-1111	WIRE CROSS SECTIONAL AREA RANGE: 0.26-1.65mm ² [509-3,260] CIR MILS SOLID OR STRANDED	FINISH -	APPD 4-15-93 DE MILLER	NAME TERMINAL, RING TONGUE, HIGH TEMPERATURE, STRATO-THERM™			
FOR ORDER ENTRY	1-800-526-5142	THIS DRAWING IS A CONTROLLED DOCUMENT FOR AMP INCORPORATED. IT IS SUBJECT TO CHANGE AND THE CONTROLLING ENGINEERING ORGANIZATION SHOULD BE CONTACTED FOR THE LATEST REVISION.		APPD 4-15-93 JL MECKLEY	PRODUCT SPEC -	SIZE C	CAGE CODE 00779	DRAWING NO G-322872
				APPLICATION SPEC -	WEIGHT -	SCALE 10:1	SHEET 1 OF 1	