

PART NUMBER	REV	FIRST USED
680037-1	C	854400-1
680037-2	C	565435-5

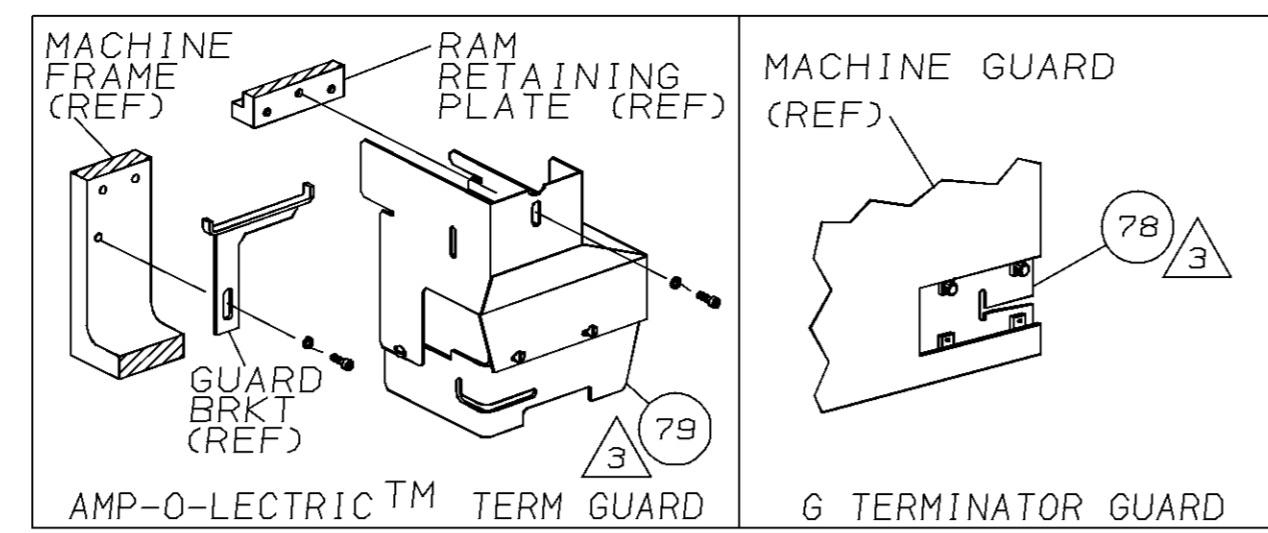

TERMINAL NAME: 2.5mm FLAG CONTACT, SOCKET						
CRIMPING DATA						
PAD LTR	CRIMP HEIGHT		WIRE SIZE			
A	.056 ± .002 [1.42 ± 0.05mm]		1mm ²			
B	.052 ± .002 [1.32 ± 0.05mm]		0.75mm ²			
C	.048 ± .002 [1.22 ± 0.05mm]		0.5mm ²			
D	NOT		USED			
CRIMP	SIZE	TYPE	RANGE			
WIRE	.080 [2.03mm]	F	0.5 - 1mm ²			
INSUL	.110 [2.79mm]	F	1.4 - 2.3mm			
WIRE STRIP LENGTH	TERM APPL	SPEC	FEED	APPL INSTRUCTION	SET UP GAGE	LAYOUT
-	-	-	.788	408-8039	458638-1	L1527

LEADMAKER & BENCH MODEL G		AIRFEED				ITEM NO	
-1						70	
-2	BENCH MODEL K	AIRFEED				68	
△	1	-	C	692655-5	AIR FEED VALVE ASSY	69	
△	REF	-	A	24042-2	VALVE, SHUT OFF	67	
△	REF	-	C	692655-6	AIR FEED VALVE ASSY	66	
△	1	1	B	460277-1	AIR FEED ASSY	65	
△	2	2	A	3-21000-9	SCR,SHC 10-32x1.00 AIR ASSY	64	
△	-	1	A	22294-6	ELBOW, TUBING 1/8NPT - 1/4 T	63	
△	-	1	A	23238-1	QUICK DISCONNECT	62	
△	12.00	12.00	IN	A	27319-4	TUBING, POLY-FLO Ø.25	61
△	1	1	C	467284-1	CAP, RAM	59	
△	1	1	D	683742-1	HOUSING	58	
△	1	1	B	679904-1	PAWL, FEED	54	
△	1	1	B	461062-1	HOLDER, FEED FINGER	53	
△	1	1	A	690191-1	PLUG, NYLON	45	
△	1	1	C	683741-2	RAM	44	
△	1	1	A	690125-1	WASHER, LAMINATED	43	
△	1	1	A	690124-9	WASHER, RAM	42	
△	1	1	A	7-21002-9	BOLT, CRIMPER(5/16-24x1.00)	41	
△	1	1	A	23241-6	BALL, STEEL	40	
△	1	1	A	690170-1	SPRING, COMPRESSION	39	
△	1	1	C	690142-1	DISC, INSULATION	38	
△	1	1	D	354777-1	WIRE DISC, PLASTIC	37	
△	1	1	A	22480-5	WASHER, SPRING	36	
△	1	1	B	690212-1	POST, RAM	35	
△	1	1	A	2-21000-6	SCR,SHC(8-32x.38)FEED HOLDER	103	
△	2	2	A	2-21006-6	SCR,SKT SET(4-40x.62)DRAG	102	
△	1	1	A	21009-2	SCR,SKT SET(1/4-20x.25)RAM	101	
△	2	2	A	21017-2	SCR,DRIVE(#2x.19)ID PLATE	100	
△	2	2	A	3-21002-0	SCR,BHC(10-32x.88)DRAG	99	
△	1	1	B	461264-1	PLATE, IDENTIFICATION	98	
△	2	2	A	2-21002-2	SCR,BHC(8-32x.50)STRIPPER	95	
△	4	4	A	2-21002-9	SCR,BHC(10-32x.75)CAP	94	
△	1	1	A	22733-8	SCR,BHC(8-32x.38 LW)ANVIL	93	
△	4	4	A	3-21002-3	SCR,BHC(1/4-20x.50)ST GD PL	92	
△	3	3	A	2-22733-8	SCR,BHC(1/4-20x.62)HSG	91	
△	1	1	A	3-21000-7	SCR,SHC(8-32x.50)SHEAR DEP	87	
△	2	2	A	2-21000-0	SCR,SHC(8-32x.50)STRIP GUIDE	86	
△	2	2	A	1-21000-3	SCR,SHC(4-40x.25)F ST GU	85	
△	1	1	A	3-21000-8	SCR,SKT CAP(10-32x.88)SH PL	80	
△	1	-	A	455750-7	GUARD ASSY	79	
△	-	-	REF	679532-1	INSERT, GUARD	78	
△	1	1	A	690603-1	SPRING, ASSIST	74	
△	1	1	A	23030-1	SCR,SKT CAP(6-32x.25)CP DSC	73	
△	-2	-1	U/M	DWG SIZE	PART NO	DESCRIPTION	ITEM NO

QTY	REV	U/M	DWG SIZE	PART NO	DESCRIPTION	ITEM NO
2	2	-	C	2-354779-4	PIN, WIRE DISC (.3110)C	129
2	2	-	C	1-354779-6	PIN, WIRE DISC (.3070)B	127
2	2	-	C	354779-7	PIN, WIRE DISC (.3025)A	126
1	1	-	A	986950-1	WASHER, FLAT PRECISION	125
						124
						123
						122
						121
						120
						119
						118
						117
						116
						115
2	2	-	A	21024-2	WASHER, LOCK (NO.4) ST GU PL	114
2	2	-	A	21024-5	WASHER, LOCK (NO.10) SHEAR PL	113
						112
						111
1	1	-	A	21024-4	WASHER, LOCK (NO.8) FEED	110
2	2	-	A	21024-3	WASHER, LOCK (NO.6) ST GU PL	109
						108
						107
1	1	-	A	22353-8	SCR,SHLD(Ø.187x.25)DRAG LEVER	105
						104
1	1	-	A	2-21000-6	SCR,SHC(8-32x.38)FEED HOLDER	103
2	2	-	A	2-21006-6	SCR,SKT SET(4-40x.62)DRAG	102
1	1	-	A	21009-2	SCR,SKT SET(1/4-20x.25)RAM	101
2	2	-	A	21017-2	SCR,DRIVE(#2x.19)ID PLATE	100
2	2	-	A	3-21002-0	SCR,BHC(10-32x.88)DRAG	99
1	1	-	B	461264-1	PLATE, IDENTIFICATION	98
						97
						96
2	2	-	A	2-21002-2	SCR,BHC(8-32x.50)STRIPPER	95
4	4	-	A	2-21002-9	SCR,BHC(10-32x.75)CAP	94
1	1	-	A	22733-8	SCR,BHC(8-32x.38 LW)ANVIL	93
4	4	-	A	3-21002-3	SCR,BHC(1/4-20x.50)ST GD PL	92
3	3	-	A	2-22733-8	SCR,BHC(1/4-20x.62)HSG	91
						90
						89
						88
1	1	-	A	3-21000-7	SCR,SHC(8-32x.50)SHEAR DEP	87
2	2	-	A	2-21000-0	SCR,SHC(8-32x.50)STRIP GUIDE	86
2	2	-	A	1-21000-3	SCR,SHC(4-40x.25)F ST GU	85
						84
						83
						82
						81
2	2	-	A	3-21000-8	SCR,SKT CAP(10-32x.88)SH PL	80
1	-	-	A	455750-7	GUARD ASSY	79
-	-	-	REF	679532-1	INSERT, GUARD	78
						77
						76
						75
1	1	-	A	690603-1	SPRING, ASSIST	74
1	1	-	A	23030-1	SCR,SKT CAP(6-32x.25)CP DSC	73
						72
						71

QTY REQD PER ASSY	REV	U/M	DWG SIZE	PART NO	DESCRIPTION	ITEM NO

PARTS LIST			
QTY	REV	U/M	DWG SIZE

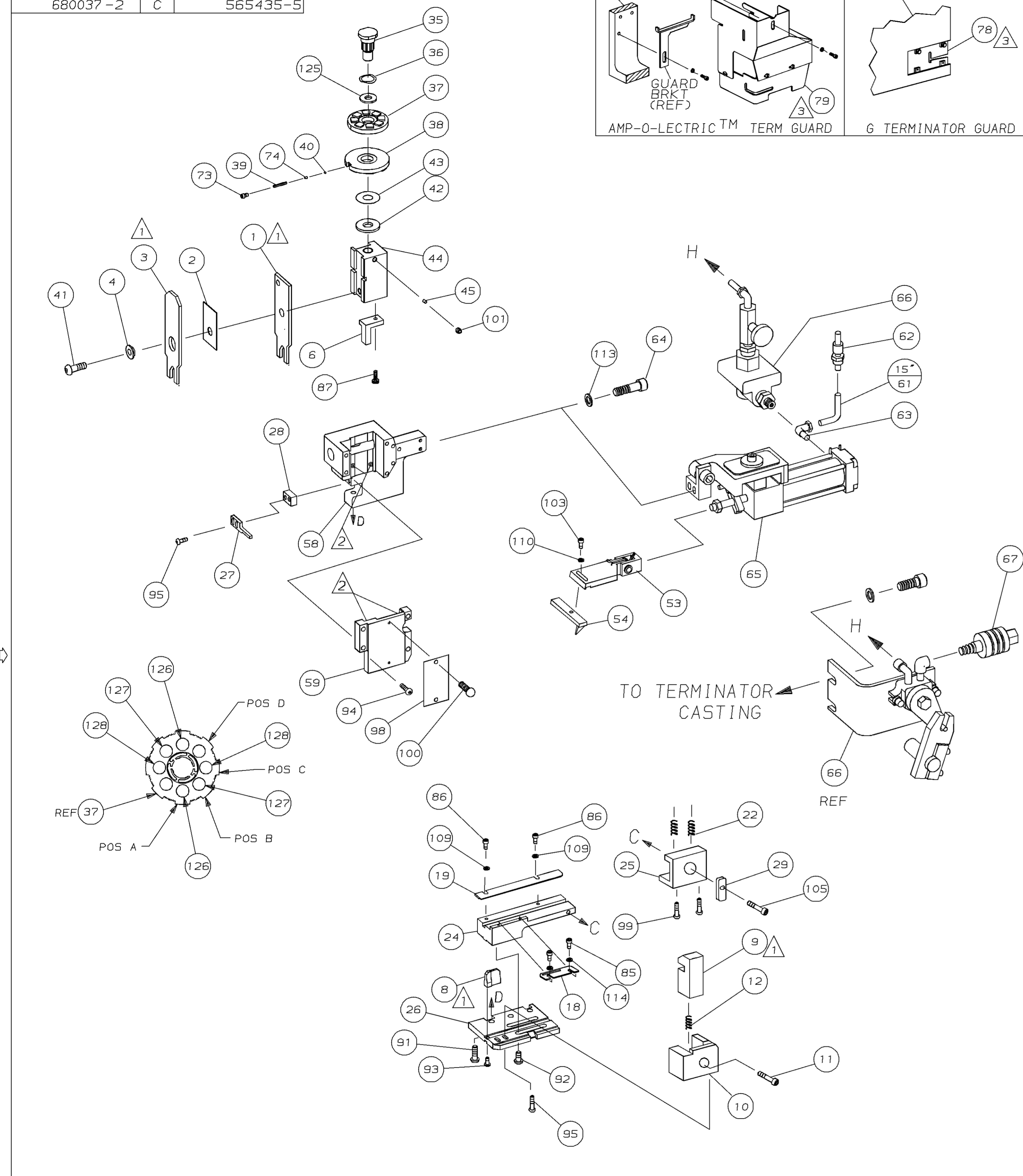

- △ 1 RECOMMENDED SPARE PARTS.
- △ 2 GREASE LIGHTLY.
- △ 3 GUARD MUST BE IN PLACE WHEN OPERATING APPLICATOR IN A BENCH MACHINE.
- △ 4 SEE DRAWING FOR COMPONENTS
- △ 5 ITEM 78 REQUIRED FOR BENCH G TERMINATOR ONLY.

THIS DRAWING IS A CONTROLLED DOCUMENT FOR AMP INCORPORATED. IT IS SUBJECT TO CHANGE AND THE CONTROLLING ENGINEERING ORGANIZATION SHOULD BE CONTACTED FOR THE LATEST REVISION.

THIS INFORMATION IS CONFIDENTIAL AND IS DISCLOSED TO YOU ON CONDITION THAT NO FURTHER DISCLOSURE IS MADE BY YOU TO OTHER THAN AMP PERSONNEL WITHOUT WRITTEN AUTHORIZATION FROM AMP INCORPORATED, HARRISBURG, PA.

LOC A
DIST 66