

ADVANCED VOLTAGE REGULATOR

- ENABLE AND SENSE INPUTS (EN, SI) PROTECTED AGAINST NEGATIVE TRANSIENTS DOWN TO -5V
- RESET THRESHOLD ADJUSTABLE FROM 3.8 TO 4.7V
- EXTREMELY LOW QUIESCENT CURRENT, 65µA (LESS THAN 90µA) IN STANDBY MODE
- OPERATING DC SUPPLY VOLTAGE RANGE 5V - 28V
- OPERATING TRANSIENT SUPPLY VOLTAGE UP TO 40V
- HIGH PRECISION STANDBY OUTPUT VOLTAGE $5V \pm 1\%$ WITH 100mA CURRENT CAPABILITY
- OUTPUT 2 VOLTAGE $5V \pm 2\%$ WITH 400mA CURRENT CAPABILITY (ADJ WIRED TO V_{OUT2})
- OUTPUT 2 VOLTAGE ADJUSTABLE BY EXTERNAL VOLTAGE DIVIDER
- OUTPUT 2 DISABLE FUNCTION FOR STANDBY MODE

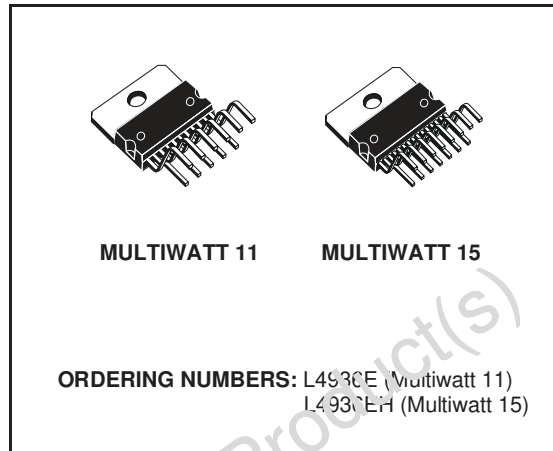

DESCRIPTION

The L4936E is a monolithic integrated dual voltage regulator with two very low dropout outputs and additional functions as power-on reset and input voltage sense. It is designed for supplying the microcomputer controlled systems especially in automotive applications.

PIN CONNECTIONS (Top views)

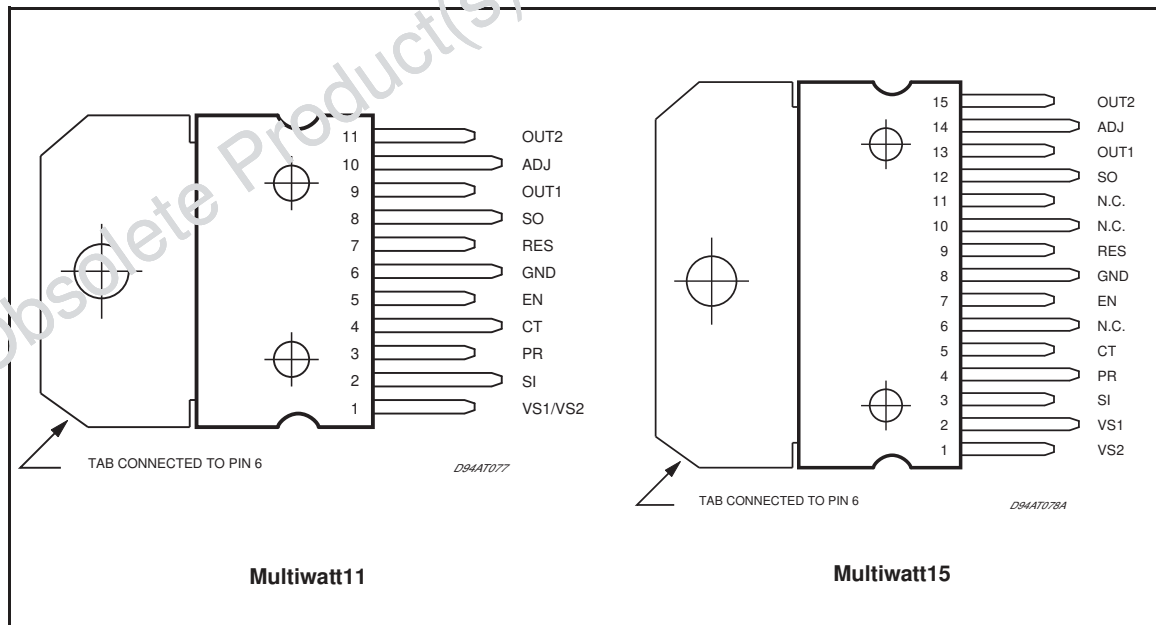

ABSOLUTE MAXIMUM RATINGS

Symbol	Parameter	Value	Unit
V_{INDC}	DC Operating Supply Voltage	28	V
V_{INTR}	Transient Operating Supply Voltage ($T < 400ms$)	-14 to 40	V
I_O	Output Current	internally limited	
V_{SI}	Sense Input Voltage (Voltage Forced) (note 2)	-20 to 20	V
I_{SI}	Sense Input Current (Current Forced) (note 2)	± 1	mA
V_{EN}	Enable Input Voltage (Voltage Forced) (note 2)	-20 to 20	V
I_{EN}	Sense Input Current (Current Forced) (note 2)	± 1	mA
V_{RES}, V_{SO}	Output Voltages	-0.3 to 20	V
I_{RES}, I_{SO}	Output Currents (Output Low)	5	mA
P_O	Power Dissipation at $T_{amb} = 80^{\circ}C$ (note 3) Multiwatt 11 (R_{th} heatsink = 9K/W)	5	W
T_{stg}	Storage Temperature	-65 to 150	$^{\circ}C$
T_j	Operating Junction Temperature	-40 to 150	$^{\circ}C$
T_{JSD}	Thermal shutdown junction temperature Output 2 will shut-down typically at T_j 10K lower than output 1	165	$^{\circ}C$

Note: The circuit is ESD protected according to MIL-STD-883C

Note 2: Current forced means voltage unlimited but current limited to the specified value
Voltage forced means voltage limited to the specified values while the current is not limited

Note 3: Typical value soldered on a PC board with 8 cm² copper ground plane (35mm thick)

BLOCK DIAGRAM

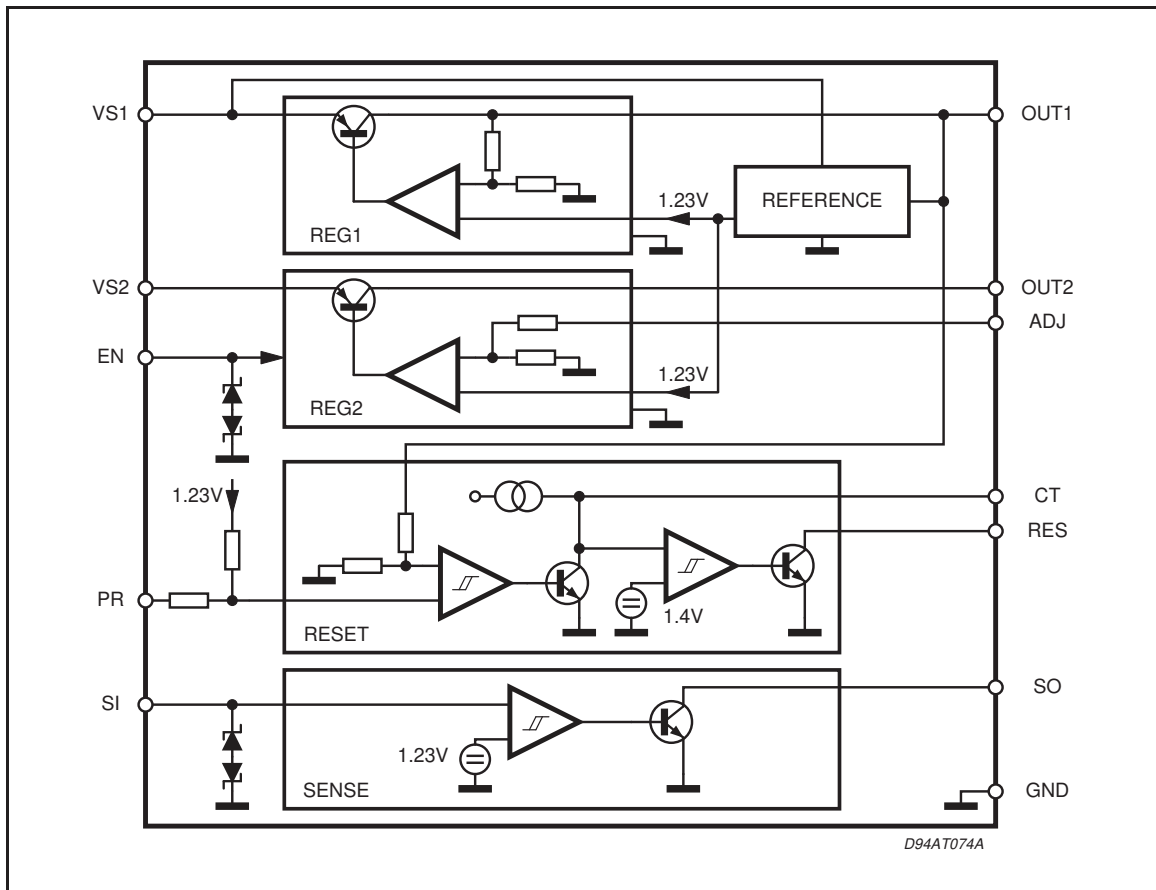

THERMAL DATA

Symbol	Parameter	MW 11	MW 15	Unit
$R_{th\ j-case}$	Thermal Resistance Junction-case	3		°C/W

Note 3: Typical value soldered on a PC board with 8 cm² copper ground plane (35mm thick)

PIN FUNCTIONS

PIN (MW 11)	PIN (MW 15)	Name	Function
1	1	VS1	Supply Voltage (400mA Regulator)
1	2	VS2	Supply Voltage (100mA Regulator, Reset, Sense)
2	3	S1	Sense Input
3	4	PR	Reset Theresold Programming
4	5	CT	Reset Delay Capacitor
5	7	EN	Enable (low will activate the 400mA regulator)
6	8	GND	Ground
7	9	RES	Reset Output
8	12	SO	Sense Output
9	13	OUT 1	100mA Regulator Output
10	14	ADJ	Feedback of 400mA Regulator
11	15	OUT 2	400mA Regulator Output
	6, 10, 11	NC	Not Connected

ELECTRICAL CHARACTERISTICS ($V_S = 14V$; $T_j = -40$ to $150^\circ C$ unless otherwise specified.)

Symbol	Parameter	Test Condition	Min.	Typ.	Max.	Unit
OUT 1						
V_{O1}	Supply Output Voltage	$V_S = 6$ to $28V$; $I_{O1} = 400\mu A$ to $100mA$	4.9	5	5.1	V
		$T_j \leq 125^\circ C$; $I_{O1} = 50$ to $400\mu A$	4.8	5	5.2	V
V_{DP1}	Dropoutput Voltage 1	$I_{OUT1} = 10mA$		0.1	0.2	V
		$I_{OUT1} = 100mA$; $V_S = 4.8V$		0.2	0.4	V
V_{OL01}	Load Regulation 1	$I_{OUT1} = 1$ to $100mA$ (after regulation setting)			25	mV
V_{LIM1}	Current Limit 1	$V_{OUT1} = 0.8$ to $4.5V$	100	200	400	mA
I_{QSB}	Quiescent Current in Standby Mode	$I_{EN} \geq 2.4V$ (output 2 disabled) $I_{O1} = 0.1mA$; $V_{SI} > 1.3V$		65	90	μA
		$T_j < 85^\circ C$; $R_{PR} = 0$		75		μA
OUT 2						
V_{O2}	Output Voltage 2 ADJ connected to OUT 2	Enable = LOW; $V_S = 6$ to $28V$; $I_{O2} = 5$ to $400mA$	4.9		5.1	V
V_{DP2}	Dropoutput Voltage 2	$I_{OUT2} = 100mA$; $V_S = 4.8V$		0.2	0.3	V
		$I_{OUT2} = 400mA$; $V_S = 4.8V$		0.3	0.6	V
V_{OL02}	Load Regulation 2	$I_{OUT1} = 5$ to $400mA$ (after regulation setting)			50	mV
R_{ADJ}	Adjust Input Resistance		60	100	150	$K\Omega$
I_{LIM2}	Current Limit 2	$V_{O2} = 0.8$ to $4.5V$	450	650	1300	mA
I_Q	Quiescent Current	$I_{OUT1} = 100mA$; $I_{OUT2} = 400mA$			20	mA
OUT1, OUT 2						
$V_{OL1,2}$	Line Regulation	$V_S = 6$ to $28V$; $I_{O1} = 1mA$, $I_{O2} = 5mA$, (after regulation setting)			20	mV

ELECTRICAL CHARACTERISTICS (Continued.)

Symbol	Parameter	Test Condition	Min.	Typ.	Max.	Unit
ENABLE INPUT						
V _{ENL}	Enable Input Low Voltage (Output 2 Active)		-20		1	V
V _{ENH}	Enable Input High Voltage		1.4		20	V
V _{ENhyst}	Enable Hysteresis		20	30	60	mV
I _{EN LOW}	Enable Input Current Low	V _{EN} = 0	-20	-8	-3	μA
I _{EN HIGH}	Enable Input Current High	V _{EN} = 1.1 to 7V; T _J < 130°C;	-1	0	1	μA
		V _{EN} = 1.1 to 7V; T _J = 130 to 150°C;	-10	0	10	μA
RESET CIRCUIT						
V _{RT}	Reset Theresold Voltage (note4)	R _{PR} = ∞	4.5	V _{O1} -0.3	V _{O1} -0.2	V
		R _{PR} = 0	3.65	3.8	3.95	V
V _{RTH}	Reset Theresold Hysteresis	R _{PR} = ∞	15	40	100	mV
t _{RD min}	Reset Pulse Delay	C _{RES} = 47nF; t _r ≤ 30μs; (note 5)	40	60	100	ms
t _{RD nom}	Reset Pulse Delay	C _{RES} = 47nF; (note 6)	60	100	140	ms
t _{RR}	Reset Reaction Time	C _{RES} = 47nF	10	50	150	μs
I _{CT}	Pull Down Capability of the Discharge circuit	V _{OUT1} < V _{RT}	3	6	15	mA
I _{CT}	Charge Current	V _{OUT1} > V _{RT}	-1.3	-1	0.7	μA
V _{RESL}	Reset Output Low Voltage	R _{RES} = 10KΩ to V _{OUT1} V _{OUT1} ≥ 1.5V			0.4	V
V _{RESH}	Reset Output High Leakage current	V _{RES} = 5V			1	μA
SENSE COMPARATOR						
V _{SI}	Functional Range		-20		20	V
V _{SIT}	Sense Threshold Voltage	Falling Edge; T _J < 130°C	1.08	1.16	1.24	V
		Falling Edge; T _J 130 to 150°C	1.05	1.16	1.29	V
V _{SITH}	Sense Threshold Hysteresis		10	30	60	mV
V _{SOL}	Sense Output Low Voltage	V _{SI} ≤ 1.05V; R _{SO} = 10KΩ connected to 5V; V _S ≥ 5V			0.4	V
I _{SOH}	Sense Output Leakage	V _{SO} = 5V; V _{SI} ≥ 1.5V			1	μA
I _{SI HIGH}	Sense Input Current High	V _{SI} = 1.1 to 7V; T _J < 130°C	-1	0	1	μA
		V _{SI} = 1.1 to 7V; T _J 130 to 150°C	-10	0	10	μA
I _{SI LOW}	Sense Input Current Low	V _{SI} = 0V	-20	-8	-3	μA

Note :

- 4) The reset threshold can be programmed continuously from typ 3.8V to 4.7V by changing a value of an external resistor from pin PR to GN
- 5) This is a minimum reset time according to the hysteresis of the comparator. Delay time starts with V_{OUT1} exceeding V_{RT}
- 6) This is the nominal reset time depending on the discharging limit of C_T (saturation voltage) and the upper threshold of the timer comparator. Delay time starts with V_{OUT1} exceeding V_{RT}
- 7) The leakage of C_T must be less than 0.5mA (2V). If an external resistor between C_T and V_{OUT1} is applied, the leakage current may be increased. The external resistor should have more than 30KΩ.
for stability: C_S ≥ 1μF, C_{O1} ≥ 10μF, C_{O2} ≥ 10μF, ESR ≤ 5Ω (designed target for resistive load) For details see application note.
- 8) For transients exceeding 20V or -20V external protection is required at the Pins SI and EN as shown at Pin EN. The protection proposed will provide proper function for transients in the range of ±200V. If the zener diode is omitted the external resistor should be raised to 200KΩ to limit the current to 1mA. Without the zener diode, the function 20V or -20V can not be guaranteed.

APPLICATION CIRCUIT

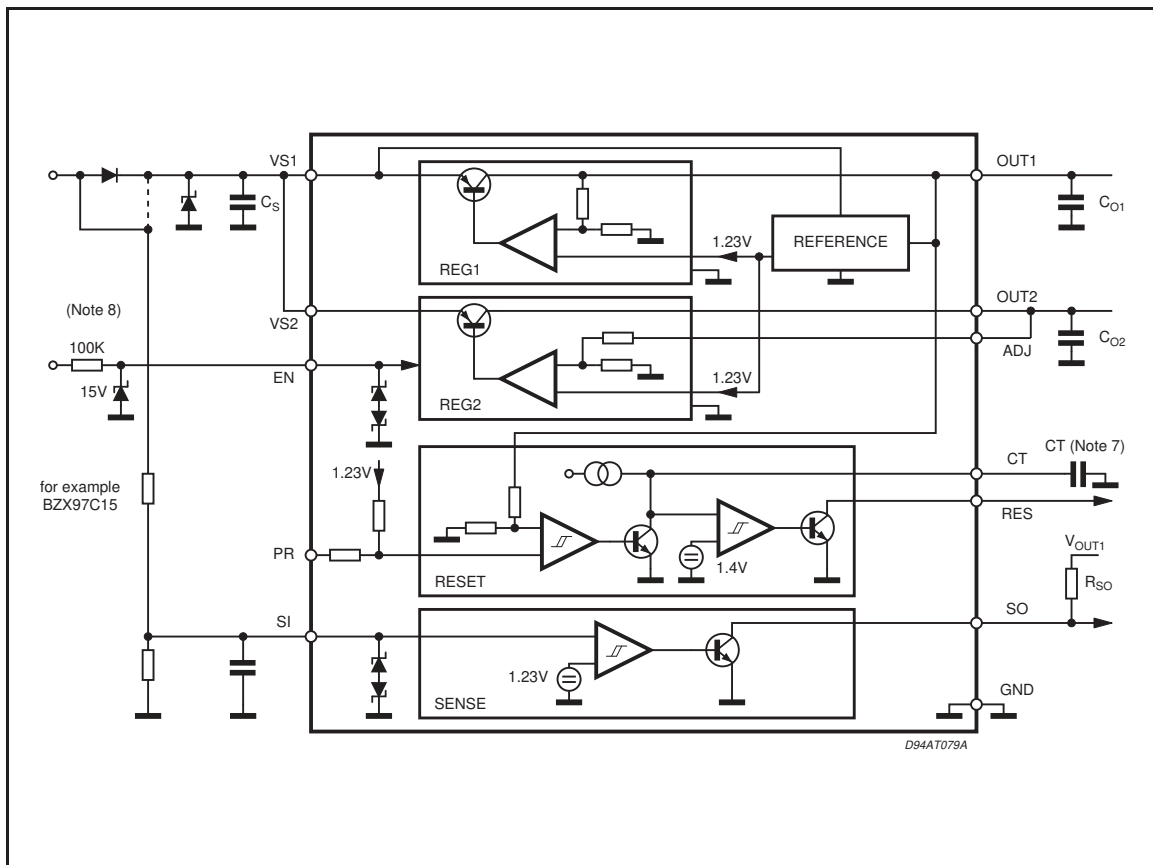

FUNCTIONAL DESCRIPTION

The L4936E is a monolithic integrated dual voltage regulator, based on the STM modulator voltage regulator approach. Several outstanding features and auxiliary functions are implemented to meet the requirements of supplying microprocessor systems in automotive applications. Nevertheless, it is suitable also in other applications where two stabilized voltages are required. The modular approach of this device allows to get easily also other features and functions when required.

Standby Regulator

The standby regulator uses an Isolated collector Vertical PNP transistor as a regulating element. With this structure very low dropout voltage at currents up to 100mA is obtained. The dropout operation of the standby regulator is maintained down to 3V input supply voltage. The output voltage is regulated up to the transient input supply voltage of 40V. With this feature no functional interruption due to overvoltage pulses is generated. In the standby mode when the output 2 is disabled, the current consumption of the device (qui-

escent current) is less than 90 μ A (14V supply voltage).

To reduce the quiescent current peak in the undervoltage region and to improve the transient response in this region, the dropout voltage is controlled. A second regulation path will keep the output voltage without load below 5.5V even at high temperatures.

Output 2 Voltage

The output 2 regulator uses the same output structure as the standby regulator but rated for the output current of 400mA. The output voltage is internally fixed to 5V if ADJ is connected to V_{OUT2}.

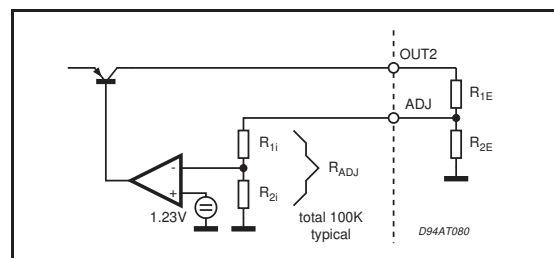

The output 2 regulator can be switched OFF via the enable input.

Connecting a resistor divider R_{1E} , R_{2E} to the ADJ, OUT2 pin the output voltage 2 can be programmed to the value of

$$V_{OUT2} = V_{OUT1} \left(1 + \frac{R_{1E}(R_{2E} + R_{ADJ})}{R_{2E} \cdot R_{ADJ}} \right)$$

with $R_{ADJ} = 60K$ to $150K$ and $V_{OUT1} = 4.95$ to $5.05V$.

For an exact calculation the temperature coefficient (T_c $-2000ppm$) of the internal resistor (R_{ADJ}) must be taken into account. Pin ADJ in this mode should not have a capacitive burden because this would reduce the phase margin of the regulator loop.

Reset circuit

The reset circuit supervises the standby output voltage. The reset output (RES) is defined from $V_{OUT} \geq 1V$.

Even if V_S is lacking, the reset generator is supplied by the output voltage V_{OUT1} .

The reset threshold of $4.7V$ is defined with the internal reference voltage (note 9) and standby output divider, when pin PR is left open. The reset threshold voltage can be programmed in the range from $3.8V$ to $4.7V$ by connecting an external resistor from pin PR to GND.

The value of the programming resistor R_{PR} can be calculated with:

$$R_{PR} = \frac{22K}{\frac{4.7V}{V_{RT}} - 1} - 92.9K, 3.8V \leq V_{RT} \leq 4.7V$$

The reset pulse delay time t_{RD} , is defined with the charge time of an external capacitor C_T :

$$t_{RDmin} = \frac{C_T \cdot 0.6V}{1\mu A} \text{ (note 5)}$$

$$t_{RDnom} = \frac{C_T \cdot 1.4V}{1\mu A} \text{ (note 6)}$$

The reaction time of the reset circuit originates

from the noise immunity. Standby output voltage drops below the reset threshold only a bit longer than the reaction time results in a shorter reset delay time. The nominal reset delay time will be generated for standby output voltage drops longer than approximately $50\mu s$.

The minimum reset time is generated if reset condition only occurs for a short time triggering a reset pulse but not completely discharging C_T . The reset can be related to output2 on request. If higher charge currents for the reset capacitor are required a resistors from Pin C_T to OUT1, may be used to increase the current. We recommended the use of $10K\Omega$ to $5V$ as an output pull up.

Sense Comparator

The sense comparator compares an input signal with an internal voltage reference of typical $1.23V$. The use of an external voltage divider makes this comparator very flexible in the application. It can be used to supervise the input voltage either before or after the protection diode and to give additional information to the microprocessor like low voltage warnings. We recommended the use of $10K\Omega$ to $5V$ as an output pull up.

Note 9:

The reference is alternatively supplied from V_S or V_{OUT1} . If one supply is present, the reference is operating.

Thermal Protection

Both outputs are provided with an overtemperature shut down regulation power dissipation down to uncritical values.

Output 2 will shut down approximately $10K$ before output 1.

Under normal conditions shut down of output 2 will allow the chip to cool down again. Thus output 1 will be unaffected.

The thermal shut down reduces the output voltages until power dissipation and the flow of thermal energy out of the chip balance.

Transient Sensitivity

In proper operation ($V_{OUT} > 4.5V$) the reference is supplied by V_{OUT1} thus reducing sensitivity to input transients.

Precise Data will be issued as soon as samples are available.

Figure 3: Reset Generator

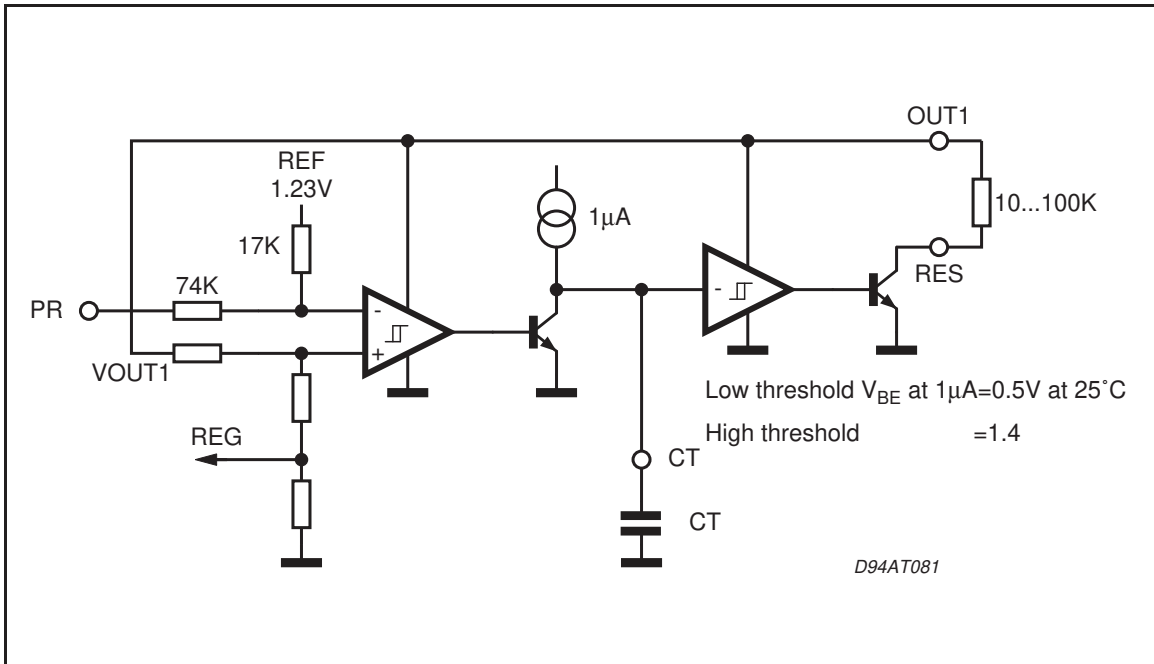
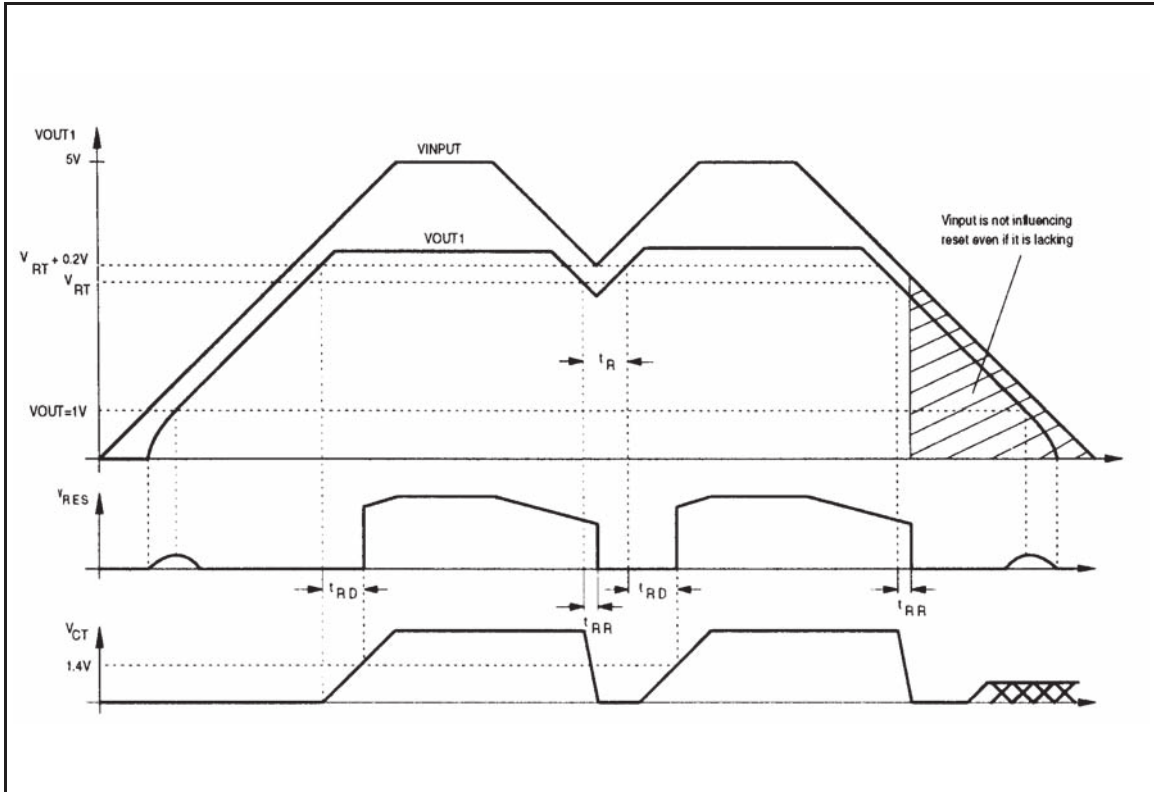

Figure 4:



INPUT PROTECTION

The Inputs Enable (EN) and sense in(SI) are pro-

ected against negative transients. Figure 5 is showing the simplified schematic

Figure 5:

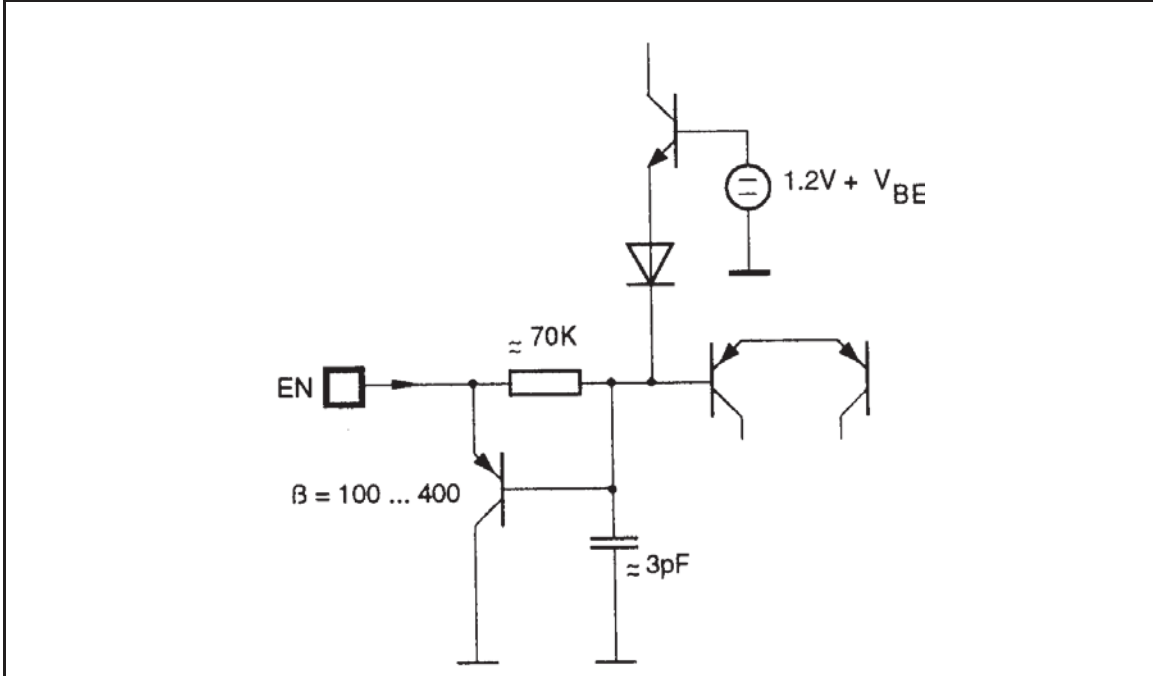

Input Characteristics of SI, EN:

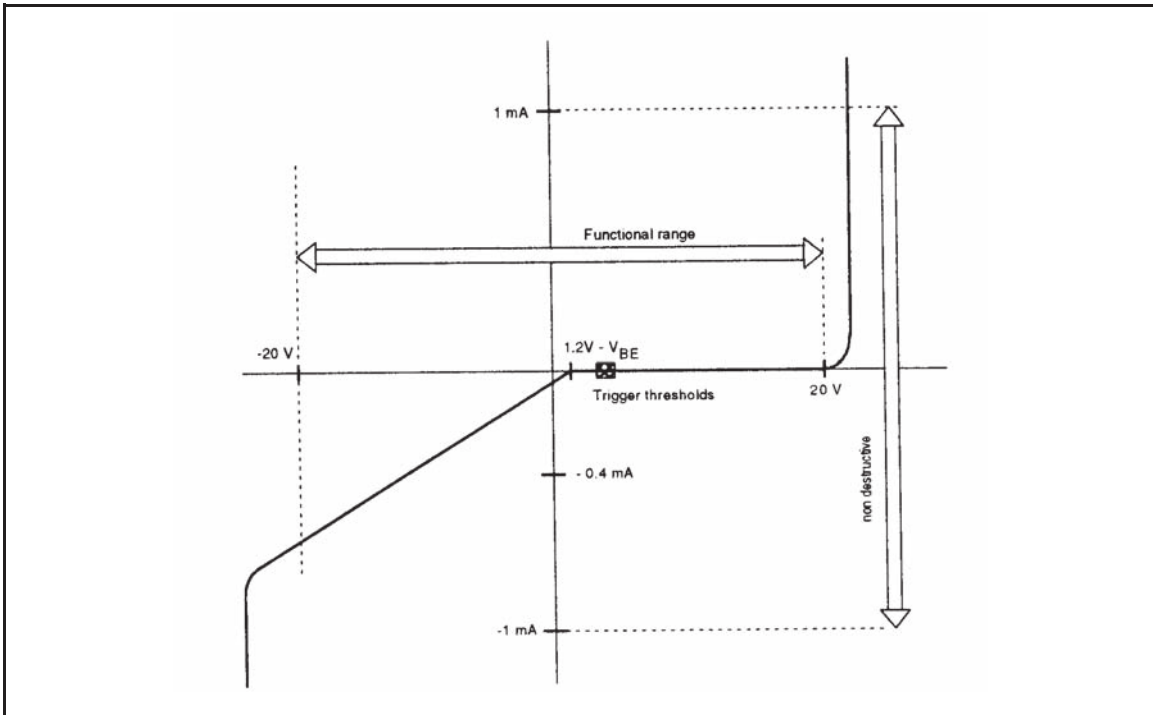

DIM.	mm			inch		
	MIN.	TYP.	MAX.	MIN.	TYP.	MAX.
A			5			0.197
B			2.65			0.104
C			1.6			0.063
D		1			0.039	
E	0.49		0.55	0.019		0.022
F	0.66		0.75	0.026		0.030
G	1.02	1.27	1.52	0.040	0.050	0.060
G1	17.53	17.78	18.03	0.690	0.700	0.710
H1	19.6			0.772		
H2			20.2			0.795
L	21.9	22.2	22.5	0.862	0.874	0.886
L1	21.7	22.1	22.5	0.854	0.870	0.886
L2	17.65		18.1	0.695		0.713
L3	17.25	17.5	17.75	0.679	0.689	0.699
L4	10.3	10.7	10.9	0.406	0.421	0.429
L7	2.65		2.9	0.104		0.114
M	4.25	4.55	4.85	0.167	0.179	0.191
M1	4.63	5.08	5.53	0.182	0.200	0.218
S	1.9		2.6	0.075		0.102
S1	1.9		2.6	0.075		0.102
Dia1	3.65		3.85	0.144		0.152

OUTLINE AND MECHANICAL DATA

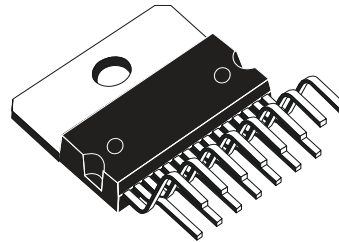

Multiwatt15 V

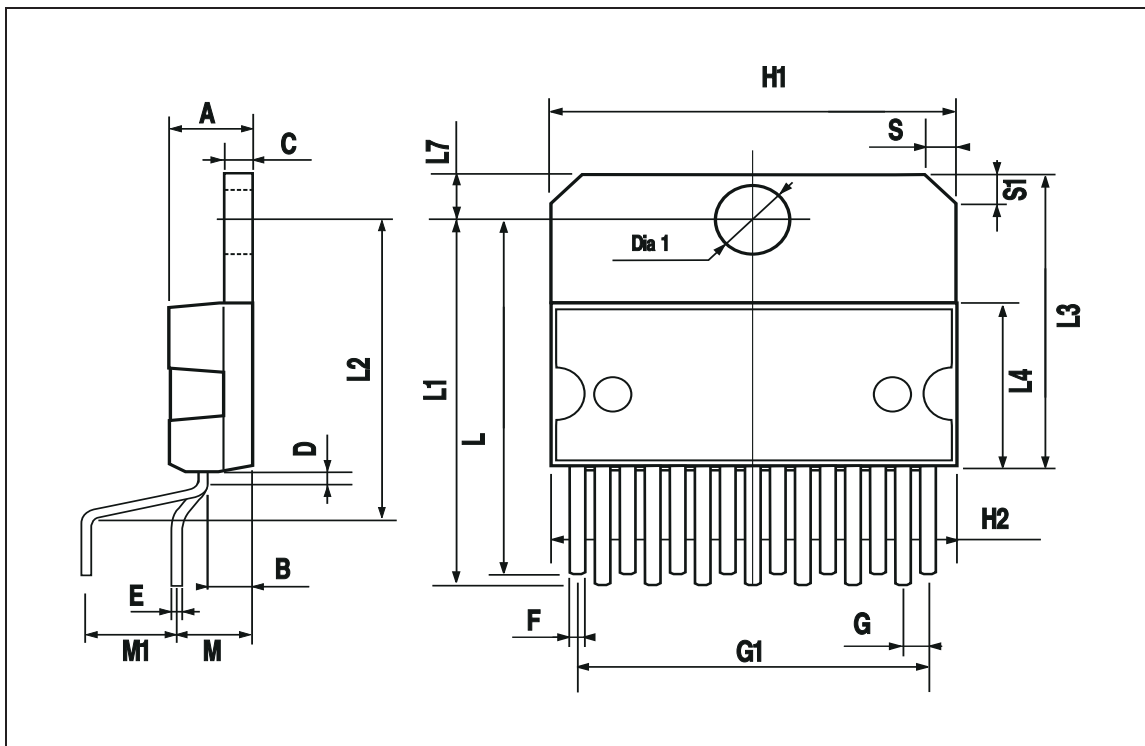

L4936E

DIM.	mm			inch		
	MIN.	TYP.	MAX.	MIN.	TYP.	MAX.
A			5			0.197
B			2.65			0.104
C			1.6			0.063
D		1			0.039	
E	0.49		0.55	0.019		0.022
F	0.88		0.95	0.035		0.037
G	1.45	1.7	1.95	0.057	0.067	0.077
G1	16.75	17	17.25	0.659	0.669	0.679
H1	19.6			0.772		
H2			20.2			0.795
L	21.9	22.2	22.5	0.862	0.874	0.886
L1	21.7	22.1	22.5	0.854	0.87	0.886
L2	17.4		18.1	0.685		0.713
L3	17.25	17.5	17.75	0.679	0.689	0.699
L4	10.3	10.7	10.9	0.406	0.421	0.429
L7	2.65		2.9	0.104		0.114
M	4.25	4.55	4.85	0.167	0.179	0.191
M1	4.73	5.08	5.43	0.186	0.200	0.214
S	1.9		2.6	0.075		0.102
S1	1.9		2.6	0.075		0.102
Dia1	3.65		3.85	0.144		0.152

OUTLINE AND MECHANICAL DATA

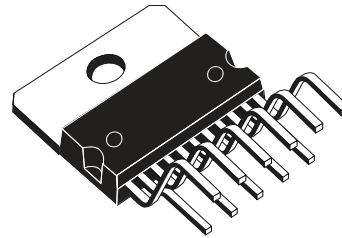

Multiwatt11 V

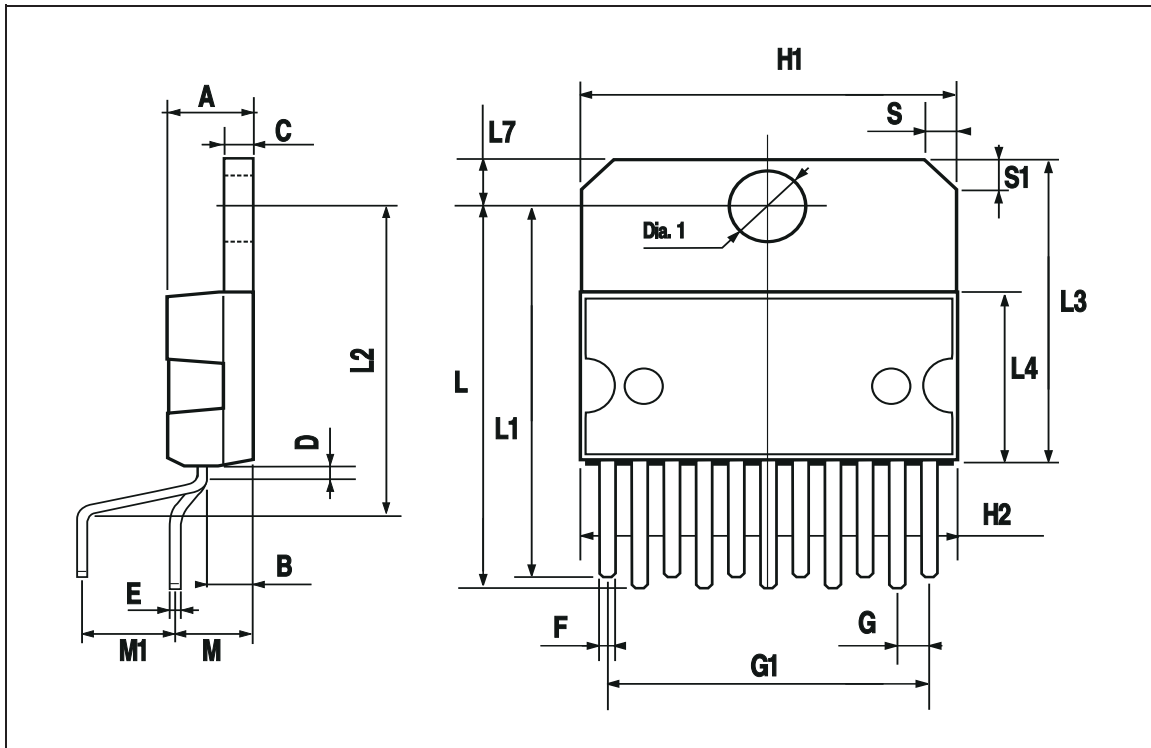

Information furnished is believed to be accurate and reliable. However, STMicroelectronics assumes no responsibility for the consequences of use of such information nor for any infringement of patents or other rights of third parties which may result from its use. No license is granted by implication or otherwise under any patent or patent rights of STMicroelectronics. Specification mentioned in this publication are subject to change without notice. This publication supersedes and replaces all information previously supplied. STMicroelectronics products are not authorized for use as critical components in life support devices or systems without express written approval of STMicroelectronics.

The ST logo is a registered trademark of STMicroelectronics
© 2000 STMicroelectronics – Printed in Italy – All Rights Reserved
STMicroelectronics GROUP OF COMPANIES

Australia - Brazil - China - Finland - France - Germany - Hong Kong - India - Italy - Japan - Malaysia - Malta - Morocco -
Singapore - Spain - Sweden - Switzerland - United Kingdom - U.S.A.

<http://www.st.com>