

SCHEMATIC	RSJ-500N-NL	RSJ-501N-NL	RSJ-502N-NL	RSJ-503N-NL
NON THREADED	RSJ-500N-NL	RSJ-501N-NL	RSJ-502N-NL	RSJ-503N-NL

NOTE:
ALL DIMS ARE IN MM.

TABLE:	
UNLESS OTHERWISE NOTED	TOL.
TOLERANCE AS FOLLOWS:	±0.3
DIMENSIONS	±0.3
0.0	±0.3
0.00	±0.15
0.000	±0.15

REVISE PRODUCT DIMENSIONS AND MATERIAL SPECS

REVISE MATERIAL SPECS

REVISED P/N TO RSJ-50X-NL SERIES

CHANGED THE DRAWING TO ROHS COMPLIANT

REVISION RECORD

ECN#	DATE	SYM
15-042	09/01/15	D
10-250	09/02/10	C
08-437	12/09/08	B
08-385	10/30/08	A
ECN#	DATE	SYM

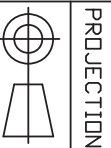

SCALE NONE

TOLERANCE NONE

DEC. INCHES N/A

DEC. MILLIMETERS N/A

SEE TABLE

ANG. N/A

No.	PART NAME	QTY	MATERIAL (THICK, COLOR)	REMARK
1	COVER	1	PRT (BLACK)	
2	HOUSING	1	PRT (BLACK)	
3	FIX TURN	1	H99 (黄/绿/蓝)	CuSn-PLATED
4	TERMINAL	1	BRASS +0.35	Ag-PLATED
5	TERMINAL	1	BRASS +0.35	Ag-PLATED
6	TERMINAL	1	PHOSPHOR BRONZE +0.30	Ag-PLATED
7	TERMINAL	1	PHOSPHOR BRONZE +0.30	Ag-PLATED
8	TERMINAL	1	BRASS +0.45	Ag-PLATED

TITLE STEREO JACK-ROHS COMPLIANT

DATE 9/26/02 REF. P/N: RSJ-50X-NL SERIES

DR. JOEY SL PRE- JK 0862 F

DATE 9/26/02 REF. P/N: RSJ-50X-NL SERIES

DR. JOEY SL PRE- JK 0862 F

THIS DOCUMENT IS OWNED BY AND THE INFORMATION CONTAINED IN IT IS PROPRIETARY TO RDI. BY RECEIPT HEREOF THE HOLDER AGREES NOT TO USE THE INFORMATION AND NOT TO DISCLOSE IT TO ANY THIRD PARTY. NO REPRODUCE THIS DOCUMENT WITHOUT THE WRITTEN CONSENT OF RDI. AND AGREES TO RETURN THIS DOCUMENT UPON REQUEST.



Research Develop Innovate

RDI, Inc. 333 North Bedford Road, Suite 135, Mount Kisco, NY 10549

SHEET 1 OF 4

REV. D

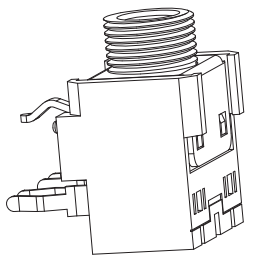
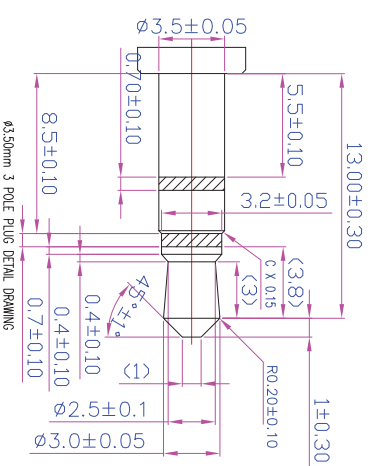
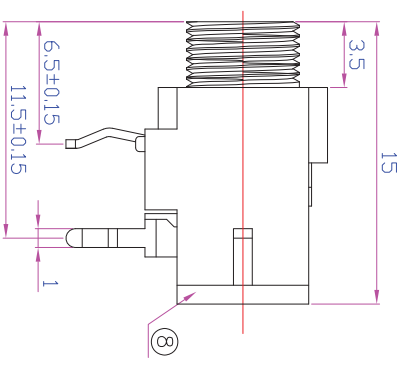
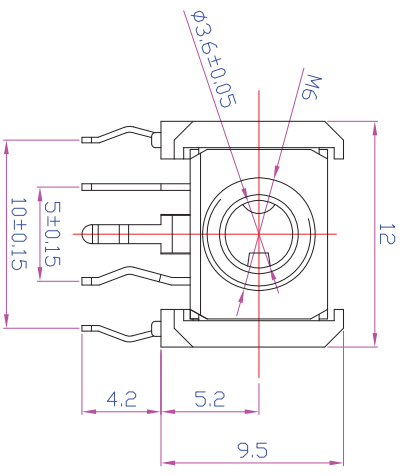
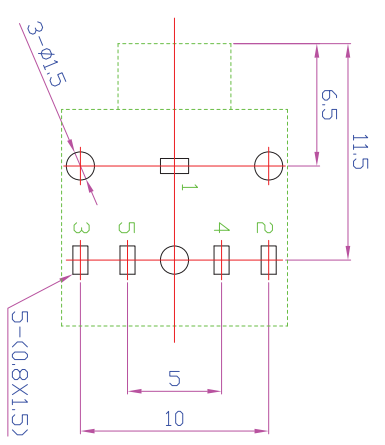
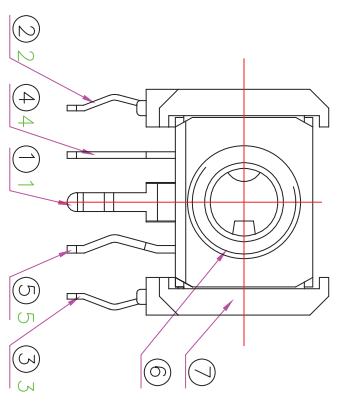
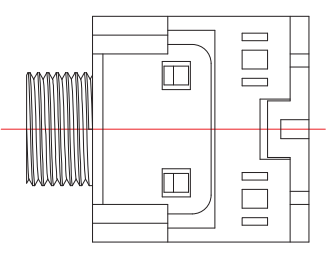

SCHEMATIC	RSJ-500-NL	RSJ-501-NL	RSJ-502-NL	RSJ-503-NL

No.	PART NAME	QTY	MATERIAL	THICK. COLOR	REMARK
1	COVER	1	PBT (BLACK)		
2	HOUSING	1	PBT (BLACK)		
3	FLX TURN	1	H59		CUSH-PLATED
4	TERMINAL	1	BRASS	1=0.40	Ag-PLATED
5	TERMINAL	1	BRASS	1=0.40	Ag-PLATED
6	TERMINAL	1	PHOSPHOR BRONZE	1=0.30	Ag-PLATED
7	TERMINAL	1	PHOSPHOR BRONZE	1=0.30	Ag-PLATED
8	TERMINAL	1	BRASS	1=0.45	Ag-PLATED

NOTE:
ALL DIMS ARE IN MM.

REV	DATE	BY	CHK	APP	DESCRIPTION
15-042	09/01/15	D	Bill C	Thno	REVISE PRODUCT DIMENSIONS AND MATERIAL SPECS
10-250	09/02/10	C	MD	AL	REVISE MATERIAL SPECS
08-437	12/09/08	B	CP	JY	REVISED P/N TO RSJ-50X-NL SERIES
08-385	10/30/08	A	CP	JY	CHANGED THE DRAWING TO ROHS COMPLIANT
ECN#	DATE	SYM	AUTH	BY	REVISION RECORD



PROJECTION: NONE
SCALE: NONE
TOLERANCE: DEC. MILLIMETERS EXCEPT AS NOTED
DEC. INCHES: N/A
DEC. MILLIMETERS SEE TABLE
ANG.: N/A



Research Develop Innovate

RDI, Inc. 333 North Bedford Road, Suite 135, Mount Kisco, NY 10549

TITLE: STEREO JACK-ROHS COMPLIANT

DR: JOEY DATE: 9/26/02 REF: P/N: RSJ-50X-NL SERIES SHEET 2 OF 4
 CK: SL PRE: JK DRAWING NO: 0862 REV. D
 SIZE: F

THIS DOCUMENT IS OWNED BY, AND THE INFORMATION CONTAINED IN IT IS PROPRIETARY TO, RDI. BY RECEIPT HEREOF THE HOLDER AGREES NOT TO USE THE INFORMATION AND NOT TO DISCLOSE IT TO ANY THIRD PARTY. NDR REPRODUCE THIS DOCUMENT WITHOUT THE WRITTEN CONSENT OF RDI, AND AGREES TO RETURN THIS DOCUMENT FORTHWITH UPON REQUEST.

SPECIFICATION

<p>1. GENERAL SCOPE</p> <p>THIS SPECIFICATION COVERS THE GENERAL REQUIREMENTS OF THE 3.5mm EARPHONE JACK, USED ON AUDIO SYSTEMS AND OTHER RELATED ELECTRONIC APPARATUS. THIS SPECIFICATION APPLIES TO THE NORMAL PLASTIC FOR THE THROUGH HOLE SOLDERING PROCESS.</p> <p>MATED PLUG THE MATED PLUG SHOULD COMPLIED WITH STANDARD PLUG AS SHOWN IN THE DRAWING ATTACHED.</p> <p>2. MECHANICAL</p> <p>2a. TERMINAL STRENGTH THE TERMINALS SHALL BE CAPABLE OF WITHSTANDING A FORCE OF 500 GRAMS APPLIED IN ANY DIRECTION FOR 10 SECONDS WITHOUT LOOSENING OR BREAKDOWN, WITH EXCEPTION OF BENDING THE TERMINALS.</p> <p>2b. INSERTION AND EXTRACTION FORCE</p> <table border="1" style="width: 100%; border-collapse: collapse;"> <tr> <th>CONDITIONS</th> <th>VALUE OF SPEC.</th> </tr> <tr> <td>INITIAL CONDITION</td> <td>0.4 KGS TO 3.0 KGS</td> </tr> <tr> <td>AFTER LIFE TEST</td> <td></td> </tr> <tr> <td>AFTER HUMIDITY TEST</td> <td></td> </tr> <tr> <td>AFTER HEAT TEST</td> <td></td> </tr> <tr> <td>AFTER COLD TEST</td> <td>0.3 KGS TO 3.0 KGS</td> </tr> <tr> <td>AFTER RESISTANCE TO SOLDERING HEAT TEST</td> <td></td> </tr> </table> <p>EXTRACTION FORCE</p> <table border="1" style="width: 100%; border-collapse: collapse;"> <tr> <th>CONDITIONS</th> <th>VALUE OF SPEC.</th> </tr> <tr> <td>INITIAL CONDITION</td> <td>0.4 KGS TO 3.0 KGS</td> </tr> <tr> <td>AFTER LIFE TEST</td> <td></td> </tr> <tr> <td>AFTER HUMIDITY TEST</td> <td></td> </tr> <tr> <td>AFTER HEAT TEST</td> <td></td> </tr> <tr> <td>AFTER COLD TEST</td> <td>0.3 KGS TO 3.0 KGS</td> </tr> <tr> <td>AFTER RESISTANCE TO SOLDERING HEAT TEST</td> <td></td> </tr> </table> <p>3. ELECTRICAL</p> <p>3a. WITHSTAND VOLTAGE TEST 500 VOLTS AC/RMS OF COMMERCIAL FREQUENCY 50 TO 60 Hz APPLIED BETWEEN ADJACENT OPEN TERMINALS FOR 1 MINUTE WITHOUT BREAKDOWN.</p> <p>3b. INSULATION RESISTANCE THE INSULATION RESISTANCE BETWEEN MUTUAL INSULATED CONTACTS SHOULD COMPLY WITH FOLLOWING SPECIFICATION UNDER 500 VOLTS DC.</p>		CONDITIONS	VALUE OF SPEC.	INITIAL CONDITION	0.4 KGS TO 3.0 KGS	AFTER LIFE TEST		AFTER HUMIDITY TEST		AFTER HEAT TEST		AFTER COLD TEST	0.3 KGS TO 3.0 KGS	AFTER RESISTANCE TO SOLDERING HEAT TEST		CONDITIONS	VALUE OF SPEC.	INITIAL CONDITION	0.4 KGS TO 3.0 KGS	AFTER LIFE TEST		AFTER HUMIDITY TEST		AFTER HEAT TEST		AFTER COLD TEST	0.3 KGS TO 3.0 KGS	AFTER RESISTANCE TO SOLDERING HEAT TEST	
CONDITIONS	VALUE OF SPEC.																												
INITIAL CONDITION	0.4 KGS TO 3.0 KGS																												
AFTER LIFE TEST																													
AFTER HUMIDITY TEST																													
AFTER HEAT TEST																													
AFTER COLD TEST	0.3 KGS TO 3.0 KGS																												
AFTER RESISTANCE TO SOLDERING HEAT TEST																													
CONDITIONS	VALUE OF SPEC.																												
INITIAL CONDITION	0.4 KGS TO 3.0 KGS																												
AFTER LIFE TEST																													
AFTER HUMIDITY TEST																													
AFTER HEAT TEST																													
AFTER COLD TEST	0.3 KGS TO 3.0 KGS																												
AFTER RESISTANCE TO SOLDERING HEAT TEST																													

CONDITION	VALUE OF SPEC.
INITIAL CONDITION	100 MΩ MIN
AFTER LIFE TEST	
AFTER HEAT TEST	100 MΩ MIN
AFTER COLD TEST	
AFTER RESISTANCE TO SOLDERING HEAT TEST	
AFTER HUMIDITY TEST	50 MΩ MIN

NOTE: THE MATE PLUG USED FOR THIS MEASUREMENT SHALL BE CLEANED TO REMOVE OXIDATION FILM ON THE SURFACE BEFORE TEST.

3c. CONTACT RESISTANCE
CONTACT RESISTANCE OF JACK SHALL NOT EXCEED THE VALUE DEFINED IN THE TABLE LISTED AT A CURRENT LESS THAN 1.0 AMP. DC BY FOUR TERMINALS METHOD.

CONDITIONS	VALUE OF SPEC.
INITIAL CONDITION	P.LUG TO CONTACTS P.LUG TO SHUNT
AFTER HUMIDITY TEST	50 mΩ MAX. 30 mΩ MAX.
AFTER HEAT TEST	
AFTER COLD TEST	50 mΩ MAX. 30 mΩ MAX.
AFTER RESISTANCE TO SOLDERING HEAT TEST	
AFTER DURABILITY TEST	100 mΩ MAX. 60 mΩ MAX.

NOTE: THE MATE PLUG USED FOR THIS MEASUREMENT SHALL BE CLEANED TO REMOVE OXIDATION FILM ON THE SURFACE BEFORE TEST.

4. ENDURANCE DURABILITY TEST
THE DURABILITY TEST SHALL CONSIST OF 5000 MATING CYCLES OF INSERTION AND EXTRACTION WITH THE MATED PLUG OR THE GAUGE PLUG AT A RATE 10-20 CYCLES PER MINUTE, NO LOAD CONDITION, WITH OR WITHOUT LUBRICANT, WHICH SHOULD BE SPECIFIED IN THE DETAIL REQUIREMENT. THE PERFORMANCE OF THE JACK BEFORE AND AFTER THIS TEST SHOULD COMPLY WITH PARAGRAPHS 2b AND 3c.

MEASURING CONDITION
ALL MEASUREMENTS AND TESTS SHALL BE PERFORMED AT A TEMPERATURE 10°C TO 35°C WITH A RELATIVE HUMIDITY OF 45%RH TO 85%RH UNDER STANDARD ATMOSPHERIC PRESSURE UNLESS OTHERWISE SPECIFIED.

15-042	09/01/15	D	REVISE PRODUCT DIMENSIONS AND MATERIAL SPECS
10-250	09/02/10	C	REVISE MATERIAL SPECS
08-437	12/09/08	B	REVISED P/N TO RSJ-50X-NL SERIES
08-385	10/30/08	A	CHANGED THE DRAWING TO ROHS COMPLIANT
ECN#	DATE	SYM	REVISION RECORD

Bill C	Thro	DR	DATE	REF.	SHEET
MD	AL	JOEY	9/26/02	P/N, RSJ-50X-NL SERIES	3 OF 4
CP	JY	SL	PRE-DRAWING NO.	0862	REV. D
CP	JY		SIZE	F	
AUTH	BY	ANG.			
		N/A			



Research Develop Innovate

RDI, Inc. 333 North Bedford Road, Suite 135, Mount Kisco, NY 10549

STEREO JACK-ROHS COMPLIANT

THIS DOCUMENT IS OWNED BY, AND THE INFORMATION CONTAINED IN IT IS PROPRIETARY TO, RDI. BY RECEIPT HEREOF THE HOLDER AGREES NOT TO USE THE INFORMATION AND NOT TO DISCLOSE IT TO ANY THIRD PARTY, NOR REPRODUCE THIS DOCUMENT WITHOUT THE WRITTEN CONSENT OF RDI, AND AGREES TO RETURN THIS DOCUMENT UPON REQUEST.

SPECIFICATION

REMARK:
THIS SPECIFICATION SUIT FOR ALL KIND OF FULL SHIELD MINI-PIN, GENERAL TYPE.

- 5. ENVIRONMENT
 - 5a. HUMIDITY TEST
THE JACK SHALL BE PLACED IN THE TESTING CHAMBER AT THE CONDITION OF 40°C±2°C AND A RELATIVE HUMIDITY OF 90% TO 95% RH FOR 96 HRS. THE DEW DROPS ON THE SURFACE OF JACK SHALL BE BLOWN OFF AND REMOVED FROM THE SURFACE OF JACK AND THEN PLACED IN AMBIENT TEMPERATURE FOR MORE THAN A 30 MINUTES. RECOVERY PERIOD, THE RELATIVE TEST BEFORE AND AFTER THIS TEST SHOULD COMPLY WITH PARAGRAPH 2b AND 3.
 - 5b. HEAT TEST
THE JACK SHALL BE PLACED IN THE TESTING CHAMBER AT A TEMPERATURE OF 70°C±2°C AND A RELATIVE HUMIDITY OF LESS THAN 50% RH FOR 96 HRS. AND THEN PLACED IN AMBIENT TEMPERATURE FOR MORE THAN A 30 MINUTE RECOVERY PERIOD. THE RELATIVE TEST BEFORE AND AFTER THIS SHOULD COMPLIED WITH PARAGRAPHS 2b AND 3.
 - 5c. COLD TEST
THE JACK SHALL BE PLACED IN THE TESTING CHAMBER AT A TEMPERATURE OF 40°C±2°C AND THE RELATIVE HUMIDITY OF LESS THAN 50% RH FOR 96 HRS. AND THEN PLACED IN AMBIENT TEMPERATURE FOR MORE THAN A 30 MINUTE RECOVERY PERIOD. THE RELATIVE TEST BEFORE AND AFTER THIS SHOULD COMPLIED WITH PARAGRAPHS 2b AND 3.
- 6. SOLDERING TEST
 - 6a. SOLDER ABILITY
THE TERMINAL OF JACK TESTED SHALL BE DIPPED INTO SOLDERING FLUX OR EQUIVALENT FOR A PERIOD OF 5 TO 10 SECTIONS AND THEN IMMERSED INTO MOLTEN SOLDER Sn63 AT A CONTROLLED TEMPERATURE OF 240°C±5°C FOR 3 ± 0.5 SECTIONS AFTER AGING. THE COVERAGE SHOULD MORE THAN 95% BY THE MICROSCOPE OF MORE THAN 10X.
 - 6b. RESISTANCE TO SOLDERING HEAT
THE JACK MOUNTED ON PCB COMPLETED WITH ACTUAL APPLICATION, THE ALL TERMINALS OF THE JACK SHOULD BE IMMERSSED INTO MOLTEN SOLDER. Sn63, AT A CONTROLLED TEMPERATURE OF 260°C±5°C FOR 5 ± 1 SECONDS. THE RELATIVE TEST AFTER THIS TEST SHOULD COMPLY WITH PARAGRAPH 2b AND 3. THE LOOK OF THE JACK SHOULD HAVE NO REMARKABLE DETERIORATION.
 - 7. OPERATING TEMPERATURE
THE RANGE: -25°C TO +100°C
 - 8. RATING
RATED VOLTAGE: 16 VOLTS DC
RATED CURRENT: 0.3 AMPERE DC

15-042	09/01/15	D	REVISE PRODUCT DIMENSIONS AND MATERIAL SPECS
10-250	09/02/10	C	REVISE MATERIAL SPECS
08-437	12/09/08	B	REVISED P/N TO RSJ-50X-NL SERIES
08-385	10/30/08	A	CHANGED THE DRAWING TO ROHS COMPLIANT
ECN#	DATE	SYM	REVISION RECORD

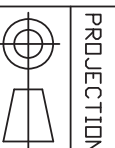

PROJECTION
SCALE NONE

TOLERANCE EXCEPT AS NOTED	DEC. INCHES	DEC. MILLIMETERS
	N/A	SEE TABLE
ANG.	N/A	

TITLE STEREO JACK-ROHS COMPLIANT



Research Develop Innovate

RDJ, Inc. 333 North Bedford Road, Suite 135, Mount Kisco, NY 10549

DR. JOEY	DATE 9/26/02	REF. P/N: RSJ-50X-NL SERIES	SHEET 4 OF 4
CK. SL	PRE- JK	DRAWING NO. 0862	REV. D
THIS DOCUMENT IS OWNED BY, AND THE INFORMATION CONTAINED IN IT IS PROPRIETARY TO, RDJ, BY RECEIPT HEREOF THE HOLDER AGREES NOT TO USE THE INFORMATION AND NOT TO DISCLOSE IT TO ANY THIRD PARTY. NDR REPRODUCE THIS DOCUMENT WITHOUT THE WRITTEN CONSENT OF RDJ, AND AGREES TO RETURN THIS DOCUMENT FORTHWITH UPON REQUEST.			