

*RoHS COMPLIANT



BOURNS®

Features

- Formerly J. W. Miller® model
- Current rating up to 3.9 A
- Inductance range: 10 μ H to 1000 μ H
- Shielded construction
- RoHS compliant*

This series is obsolete and not recommended for new designs.

Applications

- DC/DC converters
- Power supplies
- Desktop notebooks
- Output chokes

RL110S Series - Radial Lead RF Choke

Electrical Specifications (@ 25 °C)

Part Number	Inductance (μ H)	Tol.	Q	Test Frequency		SRF (MHz) Typ.	DCR (Ω) Max.	I dc (A)
				L	Q			
RL110S-100M-RC	10	$\pm 20\%$	50	2.52 MHz	2.52 MHz	32	0.023	3.9
RL110S-120M-RC	12	$\pm 20\%$	50	2.52 MHz	2.52 MHz	26	0.024	3.6
RL110S-150M-RC	15	$\pm 20\%$	50	2.52 MHz	2.52 MHz	23	0.036	3.2
RL110S-180M-RC	18	$\pm 20\%$	50	2.52 MHz	2.52 MHz	20	0.039	2.9
RL110S-220M-RC	22	$\pm 20\%$	50	2.52 MHz	2.52 MHz	14	0.042	2.6
RL110S-270M-RC	27	$\pm 20\%$	40	2.52 MHz	2.52 MHz	12	0.045	2.4
RL110S-330L-RC	33	$\pm 15\%$	40	2.52 MHz	2.52 MHz	10	0.057	2.1
RL110S-390L-RC	39	$\pm 15\%$	40	2.52 MHz	2.52 MHz	8.5	0.076	2.0
RL110S-470L-RC	47	$\pm 15\%$	40	2.52 MHz	2.52 MHz	8.0	0.10	1.8
RL110S-560L-RC	56	$\pm 15\%$	35	2.52 MHz	2.52 MHz	7.5	0.11	1.6
RL110S-680L-RC	68	$\pm 15\%$	35	2.52 MHz	2.52 MHz	6.0	0.15	1.5
RL110S-820L-RC	82	$\pm 15\%$	35	2.52 MHz	2.52 MHz	4.7	0.16	1.4
RL110S-101L-RC	100	$\pm 15\%$	30	1 KHz	0.79 MHz	4.4	0.19	1.2
RL110S-121L-RC	120	$\pm 15\%$	30	1 KHz	0.79 MHz	4.2	0.21	1.1
RL110S-151L-RC	150	$\pm 15\%$	25	1 KHz	0.79 MHz	3.6	0.23	1.0
RL110S-181L-RC	180	$\pm 15\%$	25	1 KHz	0.79 MHz	3.3	0.26	0.92
RL110S-221L-RC	220	$\pm 15\%$	25	1 KHz	0.79 MHz	3.1	0.29	0.83
RL110S-271L-RC	270	$\pm 15\%$	25	1 KHz	0.79 MHz	2.9	0.36	0.75
RL110S-331L-RC	330	$\pm 15\%$	25	1 KHz	0.79 MHz	2.7	0.51	0.68
RL110S-391L-RC	390	$\pm 15\%$	25	1 KHz	0.79 MHz	2.4	0.69	0.62
RL110S-471L-RC	470	$\pm 15\%$	25	1 KHz	0.79 MHz	1.5	0.98	0.57
RL110S-561L-RC	560	$\pm 15\%$	20	1 KHz	0.79 MHz	2.0	1.10	0.52
RL110S-681L-RC	680	$\pm 15\%$	20	1 KHz	0.79 MHz	1.8	1.20	0.47
RL110S-821L-RC	820	$\pm 15\%$	10	1 KHz	0.79 MHz	1.6	1.30	0.43
RL110S-102L-RC	1000	$\pm 15\%$	50	1 KHz	0.25 MHz	1.5	1.50	0.39

General Specifications

Rated Current..... Inductance drop 10 %, or 40 °C temperature rise at I dc
 Operating Temperature -30 °C to +100 °C
 Storage Temperature -30 °C to +100 °C

Materials

Core Material..... Ferrite
 Wire Enameled copper
 Terminal Coating..... Sn/Ag/Cu alloy

Marking

..... Value code on top of inductor

Packaging

Standard..... 100 pcs. per bag

Product Dimensions

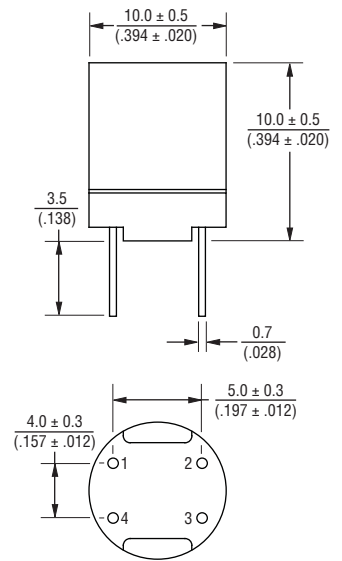

How To Order

RL110S - 471L - RC

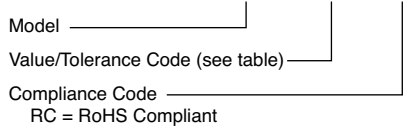

Example:
 RL110S-471L-RC = 470 μ H, $\pm 15\%$

Electrical Schematic



*RoHS Directive 2002/95/EC Jan. 27, 2003 including annex and RoHS Recast 2011/65/EU June 8, 2011.
 Specifications are subject to change without notice.
 The device characteristics and parameters in this data sheet can and do vary in different applications and actual device performance may vary over time.
 Users should verify actual device performance in their specific applications.