



FocusLCDs.com
LCDs MADE SIMPLE®

Ph. 480-503-4295 | NOPP@FocusLCD.com

TFT | CHARACTER | UWVD | FSC | SEGMENT | CUSTOM | REPLACEMENT

TFT Display Module

Part Number

E50RB-FW280-R

Overview:

- 5.0-inch TFT: 800x480
- 120.7mm H x75.8mm W
- 16/18/24-bit RGB Interface
- Top View
- Wide Temperature
- Transmissive/Normally White
- Resistive Touch Panel
- 280 NITS
- Controller: ILI5960/ILI6122
- RoHS Compliant

Description

This is a color active matrix TFT (Thin Film Transistor) LCD (Liquid Crystal Display) that uses amorphous silicon TFT as a switching device. This model is composed of a transmissive type TFT-LCD Panel, driver circuit, and a backlight unit. The resolution of the 5.0" TFT-LCD contains 800(RGB)x480 pixels and can display up to 16.7M colors.

TFT Features

Low Input Voltage: 3.3V

Display Colors: 16.7M colors

Interface: 16/18/24-bit RGB

General Information Items	Specification	Unit	Note
	Main Panel		
TFT Display area (AA)	108.00 (H) x 64.80(V) (5.0 inch)	mm	-
Driver Element	TFT active matrix	-	-
Display Colors	16.7M	colors	-
Number of pixels	800(RGB)x480	dots	-
TFT Pixel arrangement	RGB vertical stripe	-	-
Pixel pitch	0.108 (H) x 0.108 (V)	mm	-
Viewing angle	12:00	o'clock	-
TFT Controller IC	ILI5960/ILI6122	-	-
Interface	16/18/24-bit RGB	-	-
Display mode	Transmissive/ Normally White	-	-
Operating temperature	-20~+70	°C	-
Storage temperature	-30~+80	°C	-

Mechanical Information

Item		Min	Typ.	Max	Unit	Note
Module size	Height (H)		120.70		mm	-
	Vertical (V)		75.90		mm	-
	Depth (D)		4.15		mm	-
	Weight		73.00		g	-

1. Outline Dimensions

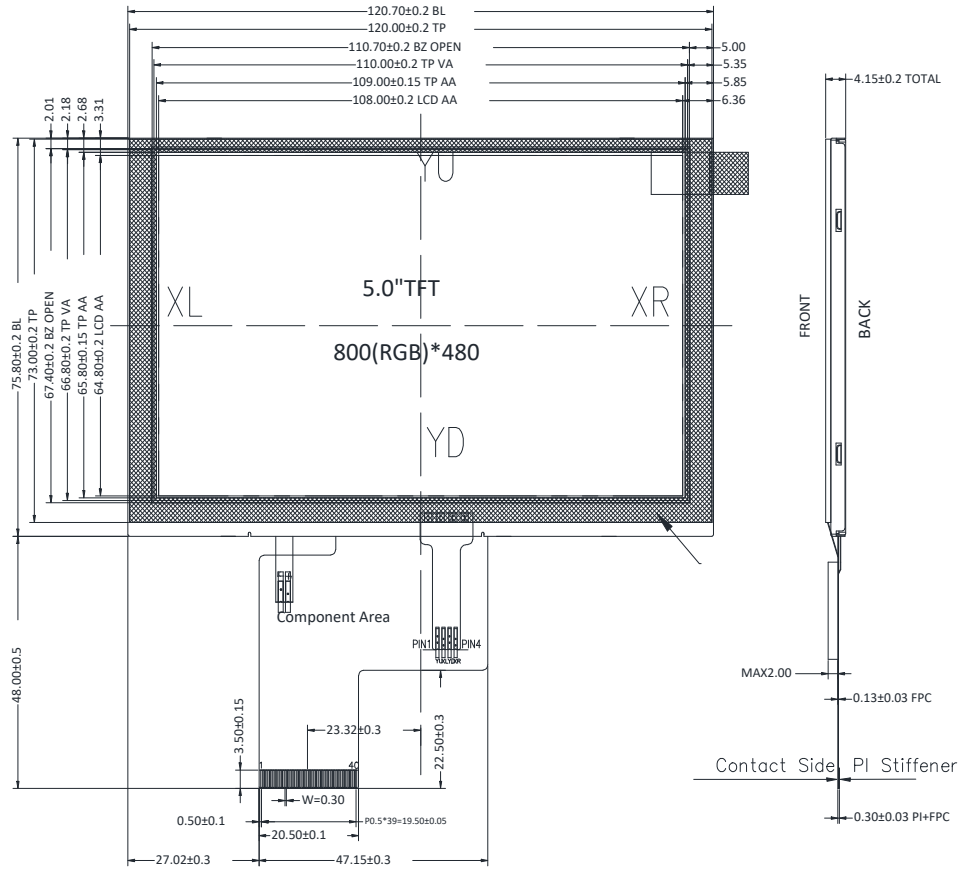

Pin	Name
1	VLED-
2	VLED+
3	GND
4	VDD
5	R0
6	R1
7	R2
8	R3
9	R4
10	R5
11	R6
12	R7
13	G0
14	G1
15	G2
16	G3
17	G4
18	G5
19	G6
20	G7
21	B0
22	B1
23	B2
24	B3
25	B4
26	B5
27	B6
28	B7
29	GND
30	PCLK
31	DISP
32	HISYNC
33	VSYNC
34	DE
35	NC
36	GND
37	XR (NC)
38	YD (NC)
39	XL (NC)
40	YU (NC)

NOTES:

1. Display type: TFT/Normally white
2. Display mode: Transmissive
3. color depth: 16.7M Colors
4. Interface Type: 24 BIT R.G.B
5. Wide viewing: 12 O'clock
6. Backlight: White Backlight 12 LED

TYP: Vf=19.2V If=40mA

7. Operating temperature: -20°C ~ +70°C
8. Storage temperature: -30°C ~ +80°C
9. ROHS COMPLIANT PRODUCT



Backlight LED Circuit

FOCUS LCDs
 LCDs MADE SIMPLE*

TOLERANCE	DRAWING NAME		
	PARTS NO.	E50RB-FW280-R	
TOLERANCE UNLESS OTHERWISE SPECIFIED X.X±0.3 X.XX±0.2	Drawn		Unit
	Checked		mm
Scale 1:1	Approve		Page 1/1

2. Block Diagram

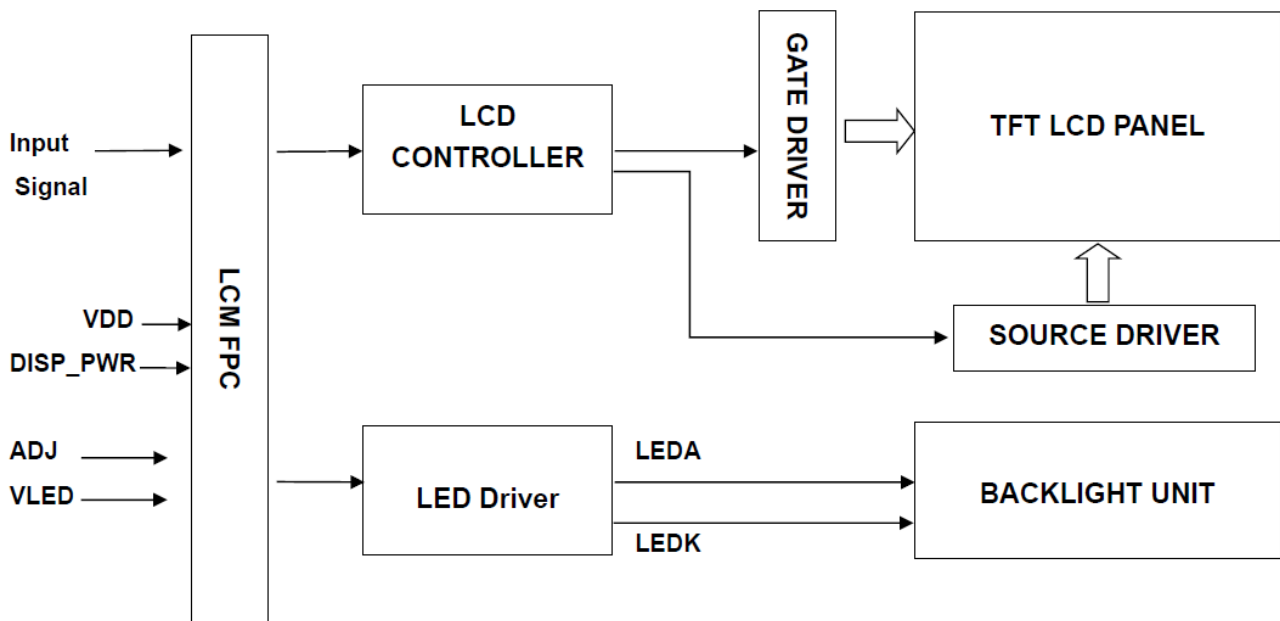

3. Input Terminal Pin Assignment

Recommended TFT Connector: FH12S-40S-0.5SH(55)

Recommended RTP Connector: FH33-4S-1SH(10)

NO.	Symbol	Description	I/O
1	VLED-	Cathode pin of the backlight	P
2	VLED+	Anode pin of the backlight	P
3	GND	Ground	P
4	VDD	Supply voltage (3.3V)	P
5	R0	Red data input	I/O
6	R1	Red data input	I/O
7	R2	Red data input	I/O
8	R3	Red data input	I/O
9	R4	Red data input	I/O
10	R5	Red data input	I/O
11	R6	Red data input	I/O
12	R7	Red data input	I/O
13	G0	Green data input	I/O
14	G1	Green data input	I/O
15	G2	Green data input	I/O
16	G3	Green data input	I/O
17	G4	Green data input	I/O
18	G5	Green data input	I/O
19	G6	Green data input	I/O
20	G7	Green data input	I/O
21	B0	Blue data input	I/O
22	B1	Blue data input	I/O
23	B2	Blue data input	I/O
24	B3	Blue data input	I/O
25	B4	Blue data input	I/O
26	B5	Blue data input	I/O
27	B6	Blue data input	I/O
28	B7	Blue data input	I/O
29	GND	Ground	P
30	PCLK	Dot clock signal for the RGB interface. Fix to VDD or GND when not used.	I
31	DISP	Standby setting for testing. Connect to VDD in normal operation mode. Connect to ground for standby mode.	I
32	HSYNC	Line synchronizing signal for the RGB interface. Fix to VDD or GND when not used.	I
33	VSYNC	Frame synchronizing signal for the RGB interface. Fix to VDD or GND when not used.	I
34	DE	Data enable signal for RGB interface. Fix to VDD or GND when not used.	I
35	NC	Not connected	-
36	GND	Ground	P
37	XR	Touch panel right glass terminal	A/D
38	YD	Touch panel bottom film terminal	A/D
39	XL	Touch panel left glass terminal	A/D
40	YU	Touch panel top film terminal	A/D

I: Input, O: Output, P: Power

4. LCD Optical Characteristics

4.1 Optical Specifications

Item	Symbol	Condition	Min	Typ.	Max	Unit	Note	
Color Gamut	S%	θ=0 Normal viewing angle	--	45	--	%	(3)	
Contrast Ratio	CR		--	500	--	%	(2)	
Response Time	Rising		TR	--	10	20	ms	(4)
	Falling		TF	--	15	30	ms	
Color Filter Chromaticity	White		W _x	0.290	0.310	0.330		(5)(6)
			W _y	0.316	0.336	0.356		
	Red		R _x	0.609	0.624	0.639		
			R _y	0.316	0.331	0.346		
	Green		G _x	0.281	0.296	0.311		
			G _y	0.562	0.577	0.592		
	Blue	B _x	0.128	0.143	0.158			
		B _y	0.094	0.109	0.124			
Viewing Angle	Hor.	θ _L	60	70	--	degree	(1)(6)	
		θ _R	60	70	--			
	Ver.	θ _T	40	50	--			
		θ _B	60	70	--			
Option View Direction	12 o'clock						(1)	

Optical Specification Reference Notes:

(1) Definition of Viewing Angle: The viewing angle is the angle at which the contrast ratio is greater than 10. The viewing angles are determined for the horizontal or 3,9 o'clock direction and the vertical or 6,12 o'clock direction with respect to the optical axis which is normal to the LCD surface.

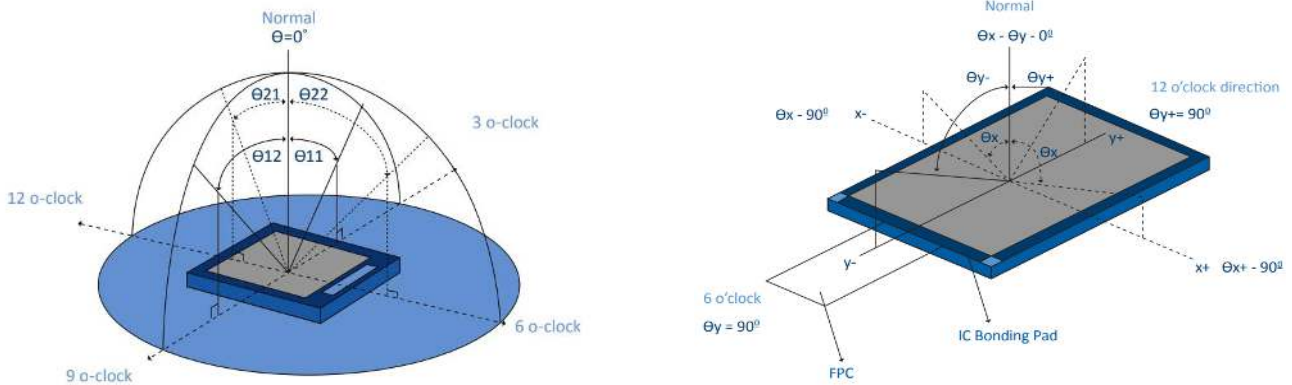

(2) Definition of Contrast Ratio (Cr): measured at the center point of panel. The contrast ratio (Cr) measured on a module, is the ratio between the luminance (Lw) in a full white area (R=G=B=1) and the luminance (Ld) in a dark area (R=G=B=0).

$$Cr = \frac{Lw}{Ld}$$

(3) Definition of transmittance (T%): The transmittance of the panel including the polarizers is measured with electrical driving. The equation for transmittance Tr is:

$$Tr = \frac{I_t}{I_o} \times 100\%$$

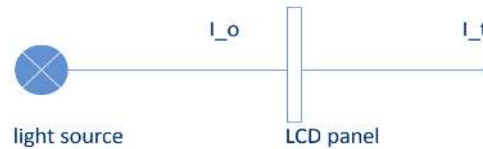

I_o = the brightness of the light source.
 I_t = the brightness after panel transmission

(4) Definition of Response Time (T_r , T_f): The rise time ' T_r ' is defined as the time for luminance to change from 90% to 10% as a result of a change of the electrical condition. The fall time ' T_f ' is defined as the time for luminance to change from 10% to 90% as a result of a change of the electrical condition.

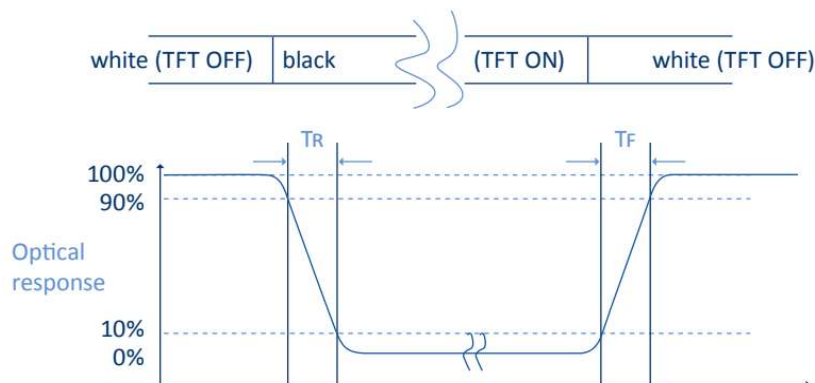

(5) Definition of Color Gamut:

Measuring machine CFT-01. NTSC's Primaries: R(x,y,Y), G(x,y,Y), B(x,y,Y). FPM520 of Westar Display Technologies, INC., which utilized SR-3 for Chromaticity and BM-5A for other optical characteristics. The color chromaticity shall be calculated from the spectral data measured with all pixels first in red, green, blue and white. Measurements shall be made at the center of the panel.

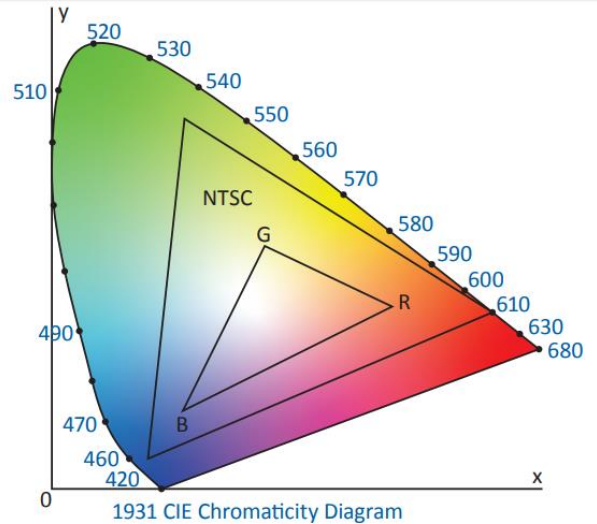
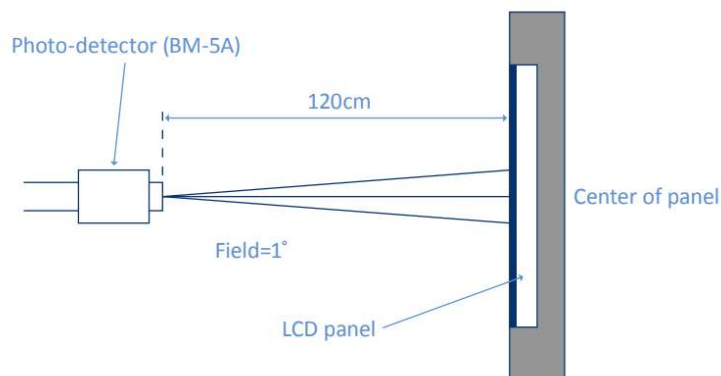
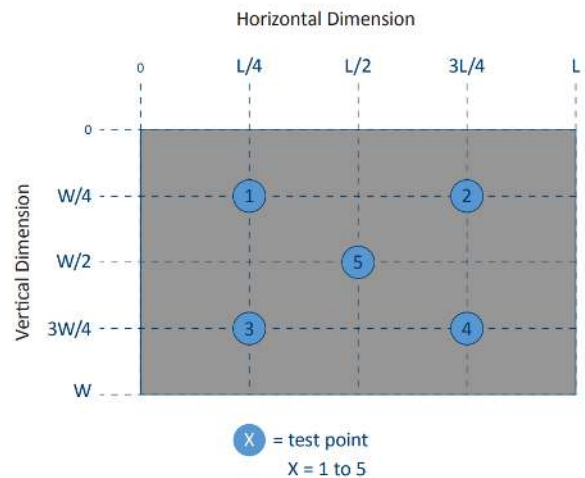
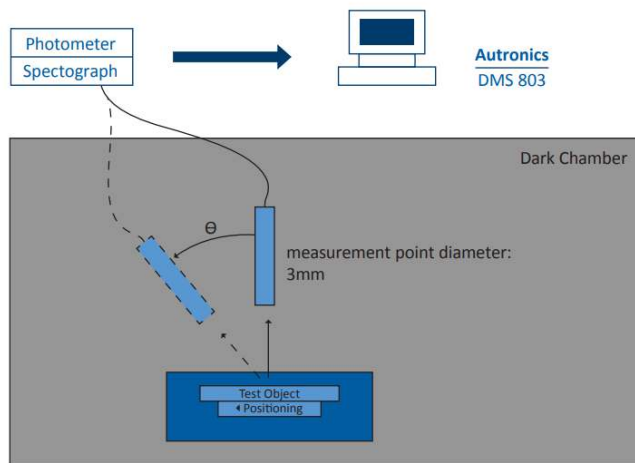

Fig. 1931 CIE chromacity diagram

$$\text{Color gamut: } S = \frac{\text{Area of RGB triangle}}{\text{Area of NTSC triangle}} \times 100\%$$

(6) Definition of Optical Measurement Setup:

The LCD module should be stabilized at a given temperature for 20 minutes to avoid abrupt temperature change during measuring. In order to stabilize the luminance, the measurement should be executed after lighting backlight for 20 minutes.



5. TFT Electrical Characteristics

5.1 Absolute Maximum Rating (Ta=25 °C, VSS=0V)

Characteristics	Symbol	Min	Max	Unit
Digital Supply Voltage	VDD	-0.3	5.0	V
Operating Temperature	TOP	-20	+70	°C
Storage Temperature	TST	-30	+80	°C

NOTE: If the absolute maximum rating of the above parameters is exceeded, even momentarily, the quality of the product may be degraded. Absolute maximum ratings specify the values which the product may be physically damaged if exceeded. Be sure to use the product within the range of the absolute maximum ratings.

5.2 DC Electrical Characteristics

Characteristics	Symbol	Min	Typ.	Max	Unit	Note
Digital Supply Voltage	VCI	3.0	3.3	3.6	V	
Normal Mode Current Consumption	IDD	--	100	200	mA	
Level Input Voltage	VIH	0.7IOVCC	--	IOVCC	V	
	VIL	GND	--	0.3IOVCC	V	
Level Output Voltage	VOH	VDD-0.4	--	--	V	
	VOL	GND	--	GND+0.4	V	

5.3 LED Backlight Characteristics

Item	Symbol	Min	Typ.	Max	Unit	Note
Forward Current	IF	30	40	--	mA	
Forward Voltage	VF	--	19.2	--	V	
LCM Luminance	LV	230	280	--	cd/m ²	Note 3
LED lifetime	Hr	--	50000	--	hour	Note1 & 2
Uniformity	AVg	70	80	--	%	Note 3

The back-light system is edge-lighting type with 12 chips White LED.

Note 1: LED lifetime (Hr) can be defined as the time in which it continues to operate under the condition: Ta=25 ±3 °C, typical IL value indicated in the above table until the brightness becomes less than 50%.

Note 2: The “LED lifetime” is defined as the module brightness decrease to 50% original brightness at Ta=25°C and IF=40mA. The LED lifetime could be decreased if operating IF is larger than 40mA. The constant current driving method is suggested.

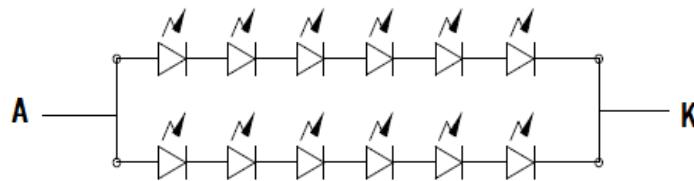

Backlight LED Circuit

Note 3: Luminance Uniformity of these 9 points is defined as below:

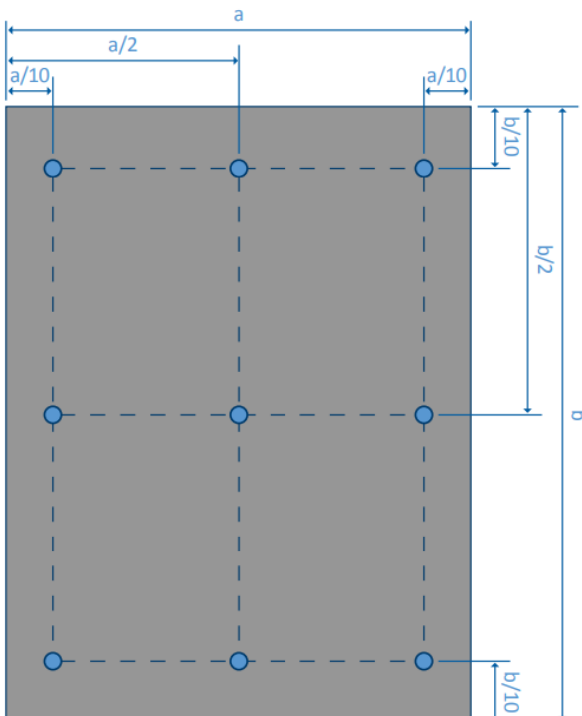

$$\text{Luminance} = \frac{\text{Total Luminance of 9 points}}{9}$$

$$\text{Uniformity} = \frac{\text{minimum luminance in 9 points(1-9)}}{\text{maximum luminance in 9 points(1-9)}}$$

6. AC Timing Characteristics

6.1 Display Interface Timing Characteristics

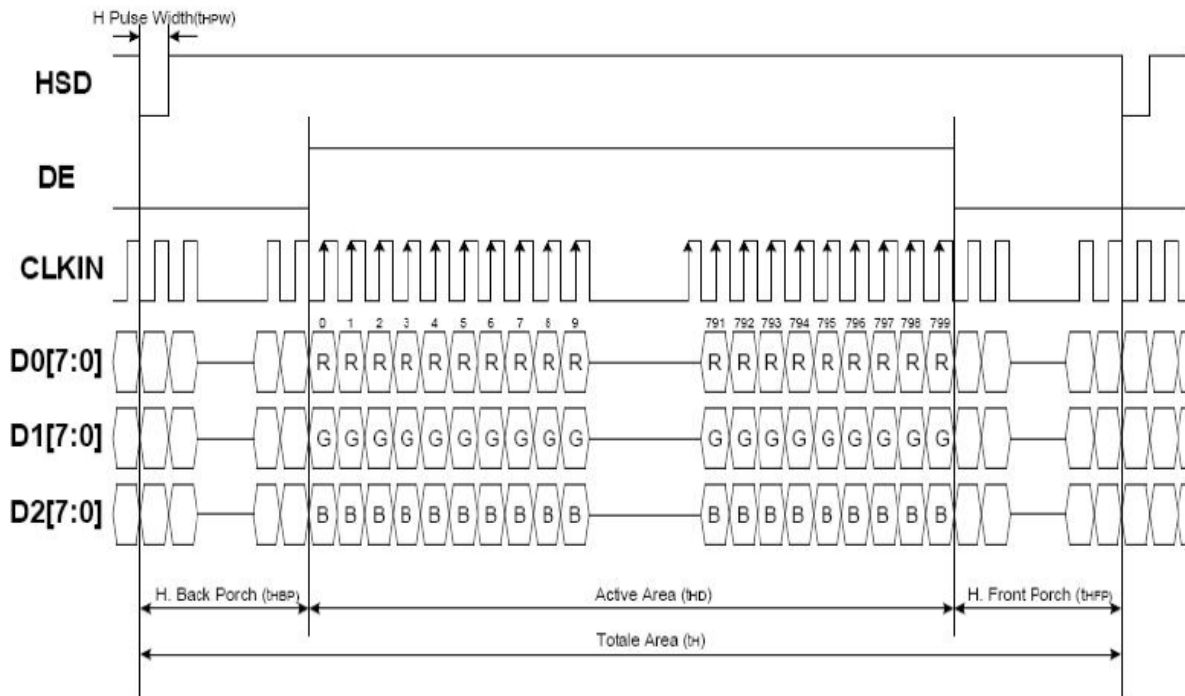

Horizontal Input Timing

Parameter	Symbol	Min	Typ.	Max	Unit
Horizontal Display Area	t_{HD}	--	800	--	CLKIN
CLKIN Frequency	f_{CLK}	--	33.3	50	MHz
1 Horizontal Line Period	t_H	862	1056	1200	CLKIN
HSD Pulse Width	Min	--	1	--	CLKIN
	Typ	--	--	--	CLKIN
	Max	--	40	--	CLKIN
HSD Back Porch	t_{HBP}	46	46	46	CLKIN
HSD Front Porch	t_{HFP}	16	210	354	CLKIN

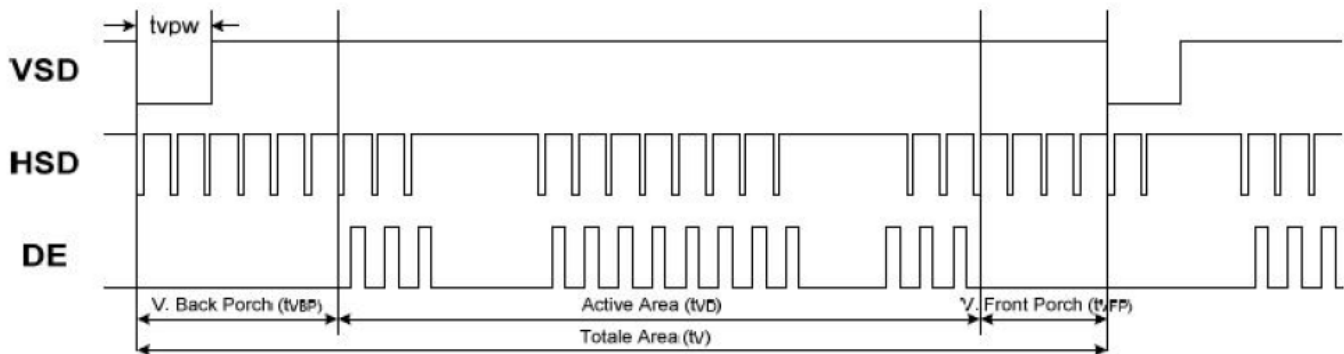

Vertical Input Timing					
Parameter	Symbol	Min	Typ.	Max	Unit
Vertical Display Area	t_{VD}	--	480	--	HSD
VSD Period Time	t_V	510	525	650	HSD
VSD Pulse Width	t_{VPW}	1	--	20	HSD
VSD Back Porch	t_{VBP}	23	23	23	HSD
VSD Front Porch	t_{VFP}	7	22	147	HSD

7. Cautions and Handling Precautions

7.1 Handling and Operating the Module

1. When the module is assembled, it should be attached to the system firmly. Do not warp or twist the module during assembly work.
2. Protect the module from physical shock or any force. In addition to damage, this may cause improper operation or damage to the module and back-light unit.
3. Note that polarizer is very fragile and could be easily damaged. Do not press or scratch the surface.
4. Do not allow drops of water or chemicals to remain on the display surface. If you have the droplets for a long time, staining and discoloration may occur.
5. If the surface of the polarizer is dirty, clean it using some absorbent cotton or soft cloth.
6. The desirable cleaners are water, IPA (Isopropyl Alcohol) or Hexane. Do not use ketene type materials (ex. Acetone), Ethyl alcohol, Toluene, Ethyl acid or Methyl chloride. It might permanent damage to the polarizer due to chemical reaction.
7. If the liquid crystal material leaks from the panel, it should be kept away from the eyes or mouth. In case of contact with hands, legs, or clothes, it must be washed away thoroughly with soap.
8. Protect the module from static; it may cause damage to the CMOS ICs.
9. Use fingerstalls with soft gloves in order to keep display clean during the incoming inspection and assembly process.
10. Do not disassemble the module.
11. Protection film for polarizer on the module shall be slowly peeled off just before use so that the electrostatic charge can be minimized.
12. Pins of I/F connector shall not be touched directly with bare hands.
13. Do not connect, disconnect the module in the "Power ON" condition.
14. Power supply should always be turned on/off by the item Power On Sequence & Power Off Sequence.

7.2 Storage and Transportation

1. Do not leave the panel in high temperature, and high humidity for a long time. It is highly recommended to store the module with temperature from 0 to 35 °C and relative humidity of less than 70%
2. Do not store the TFT-LCD module in direct sunlight.
3. The module shall be stored in a dark place. When storing the modules for a long time, be sure to adopt effective measures for protecting the modules from strong ultraviolet radiation, sunlight, or fluorescent light.
4. It is recommended that the modules should be stored under a condition where no condensation is allowed. Formation of dewdrops may cause an abnormal operation or a failure of the module. In particular, the greatest possible care should be taken to prevent any module from being operated where condensation has occurred inside.
5. This panel has its circuitry FPC on the bottom side and should be handled carefully in order not to be stressed.