

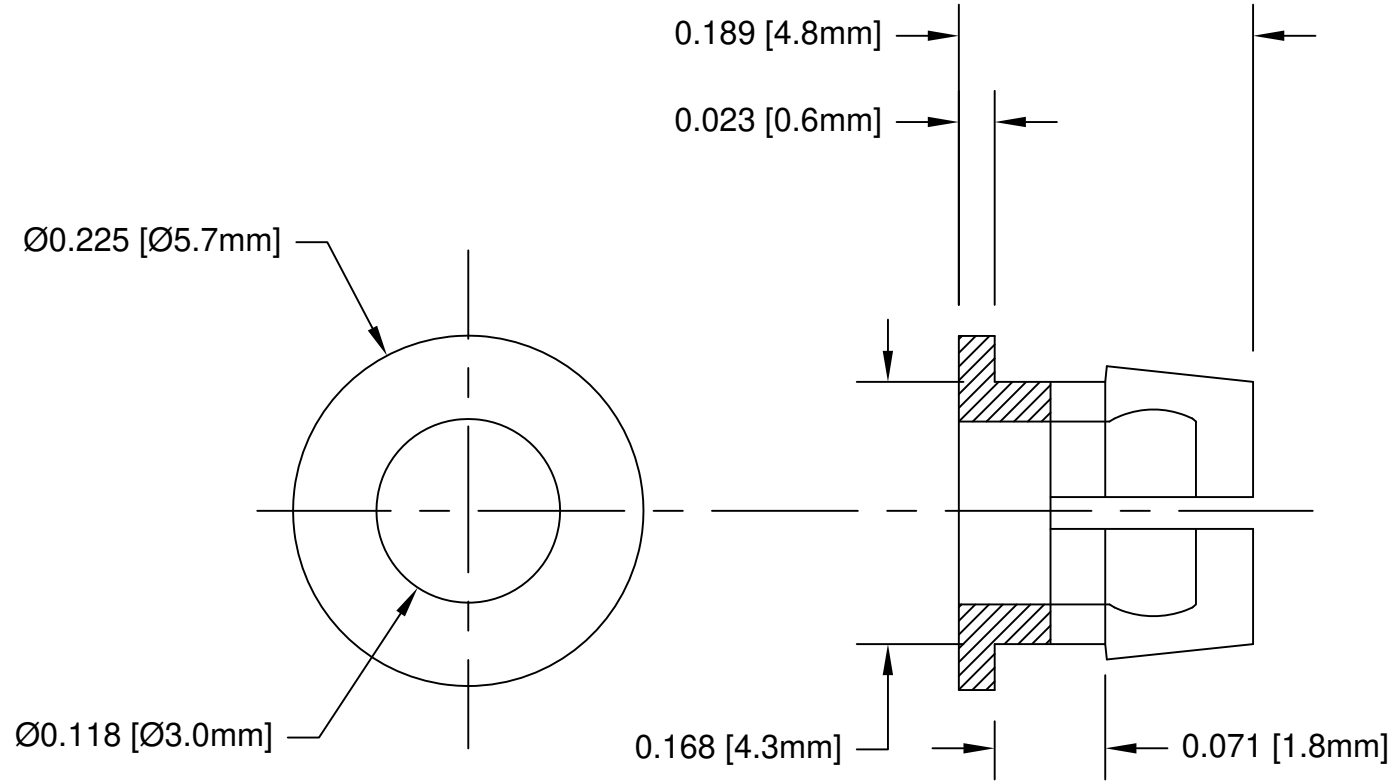

REV.	DESCRIPTION	DATE	APPROVED
A	Engineering Release	01/23/07	M. C.
B	Changed Outer Diameter from .232 to .225	03/28/07	M. C.
C	Added 0.168 Dimension	08/12/09	T. Y.
D	Removed Material Code	05/28/16	J. C.



2. MATERIAL: NYLON 6/6, 94V-2, BLACK.

1. GENERAL SPECIFICATIONS: BIVAR MOLDED COMPONENT SPECIFICATION BV00-101.

STANDARD TOLERANCE (UNLESS OTHERWISE SPECIFIED) DECIMALS ANGULAR .X ± .1 X° ± 1° .XX ± .01 .XXX ± .005		 4 THOMAS, IRVINE, CA. 92618 TEL: (949) 951-8808 FAX: (949) 951-3974	
DESIGNED: S. Dam		DATE: 01/23/07	
CHECKED: T. Yin		DATE: 01/23/07	
TITLE: T-1 (3mm) LED CLIP		PART NO: C-101	REVISION: D
CAGE CODE : 32559		SHEET # 1 OF 1	
CAD GENERATED DOCUMENT. DO NOT MEASURE DRAWING.			