

REVISIONS			
REV	DESCRIPTION, ECN, EAR NO.	DATE	APP'D
A	PROPOSAL	APR23/15	L.CHAN
B	CORRECT DIMENSION	JAN19/16	L.CHAN

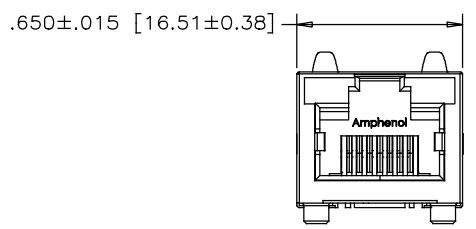

FRONT VIEW

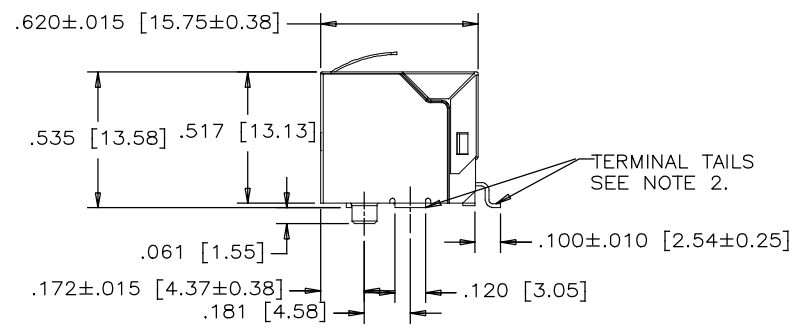

SIDE VIEW

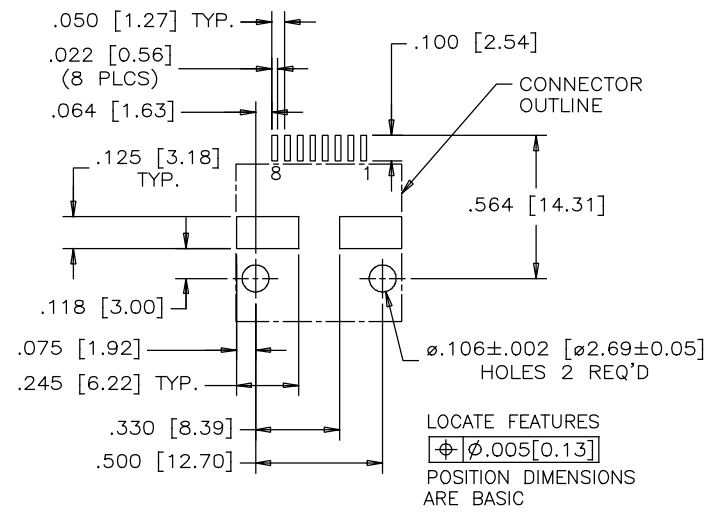

RECOMMENDED P.C.B. LAYOUT
(COMPONENT SIDE OF BOARD)

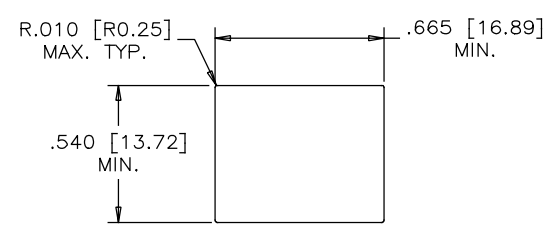

RECOMMENDED PANEL CUTOUT



1. MATERIALS:
- HOUSING: ENGINEERING THERMOPLASTIC
FLAMMABILITY RATING UL 94V-0
COLOR: BLACK
 - CONTACTS: PHOSPHOR BRONZE
PLATING: 20 μ" [1.27 MICRONS] MIN. GOLD ON MATING SURFACES.
50 μ" [1.27 MICRONS] MIN. NICKEL UNDERPLATE.
100 μ" [2.54 MICRONS] MIN. MATTE-TIN OR GOLD FLASH ON CONTACT TAILS.
 - SHIELD: COPPER ALLOY PLATED NICKEL.
2. COPLANARITY SPECIFICATION:
WITH THE MODULAR JACK SITTING ON A LEVEL SURFACE,
THE MAXIMUM GAP BETWEEN THE LEVEL SURFACE OF SHIELD
TAB AND ALL TERMINAL TAILS IS .004 [0.10].

PART NUMBER: RJSSE-5580-01T

UNLESS SPECIFIED OTHERWISE	DRAWN AMY.Z	DATE APR23/15	Amphenol Canada Corp. www.amphenolcanada.com
PRIMARY UNITS INCH	CHECKED L.CHAN	DATE APR23/15	
SECONDARY MILLIMETER	M.E. APP'D		TITLE
REFERENCE IN PARENTHESES	Q.A. APP'D		SINGLE PORT, SURFACE MOUNT RJ45, 8 POSITION, 8 CONTACTS, SHIELDED WITH FLATTEN BOTTOM TAB TAPE & REEL PACKAGING - RoHS COMPLIANT
GENERAL TOLERANCES	DWG APPR.		DWG. NO.
1 DECIMAL PLACE ±0.025	ENG. REL. NO.		P-RJSSE-5580-01T
2 DECIMAL PLACES ±0.020	REF.		REV B
3 DECIMAL PLACES ±0.015	THIRD ANGLE PROJECTION	DO NOT SCALE DRAWING	CODE ID NO. 03554 DWG SIZE: c SCALE: N/A SHEET 1 OF 2
ANGULAR DEGREES ±1.0°			

REVISIONS			
REV	DESCRIPTION, ECN, EAR NO.	DATE	APP'D
A	PROPOSAL	APR23/15	L.CHAN
B	CORRECT DIMENSION	JAN19/16	L.CHAN

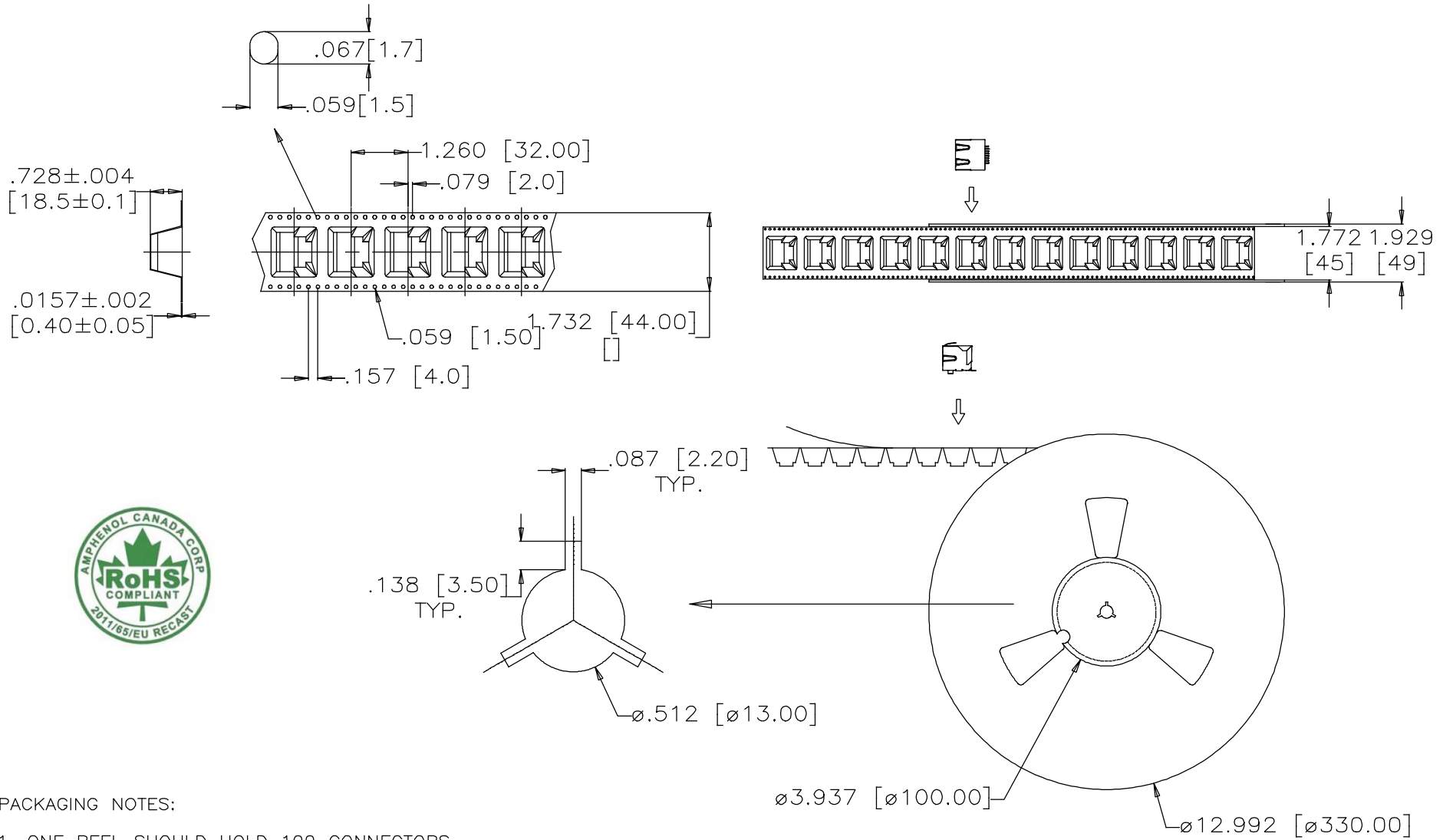

PACKAGING NOTES:

1. ONE REEL SHOULD HOLD 100 CONNECTORS.
2. 10 EMPTY CAVITIES FOR BOTH TOP AND BOTTOM OF THE CARRIER.
3. A FULLY LOADED CARTON SHOULD CONTAIN 6 REELS (600 PCS) OF CONNECTOR.

UNLESS SPECIFIED OTHERWISE	DRAWN AMY.Z	DATE APR23/15	Amphenol Canada Corp. www.amphenolcanada.com
PRIMARY UNITS INCH	CHECKED L.CHAN	DATE APR23/15	
SECONDARY MILLIMETER	M.E. APP'D		TITLE
REFERENCE IN PARENTHESES	Q.A. APP'D		SINGLE PORT, SURFACE MOUNT RJ45, 8 POSITION, 8 CONTACTS, SHIELDED WITH FLATTEN BOTTOM TAB TAPE & REEL PACKAGING - RoHS COMPLIANT
GENERAL TOLERANCES	DWG APPR.		DWG. NO.
1 DECIMAL PLACE ±0.025	ENG. REL. NO.		P-RJSSE-5580-01T
2 DECIMAL PLACES ±0.020	REF.		REV B
3 DECIMAL PLACES ±0.015	THIRD ANGLE PROJECTION	DO NOT SCALE DRAWING	CODE ID NO. 03554 DWG SIZE: c SCALE: N/A SHEET 2 OF 2
ANGULAR DEGREES ±1.0°			

THIS DOCUMENT CONTAINS PROPRIETARY INFORMATION AND SUCH INFORMATION MAY NOT BE DISCLOSED TO OTHERS FOR ANY PURPOSE OR USED FOR MANUFACTURING PURPOSES WITHOUT WRITTEN PERMISSION FROM AMPHENOL CANADA CORP.