

FB-BW-30335-000
SHT 1.1

THE FRONT SOUND PORT IS ADJACENT TO THE MODEL NUMBER IDENTIFICATION.

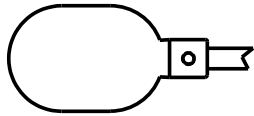

TOP VIEW
W/WINDSHIELD SHOWN
SCALE 1:1

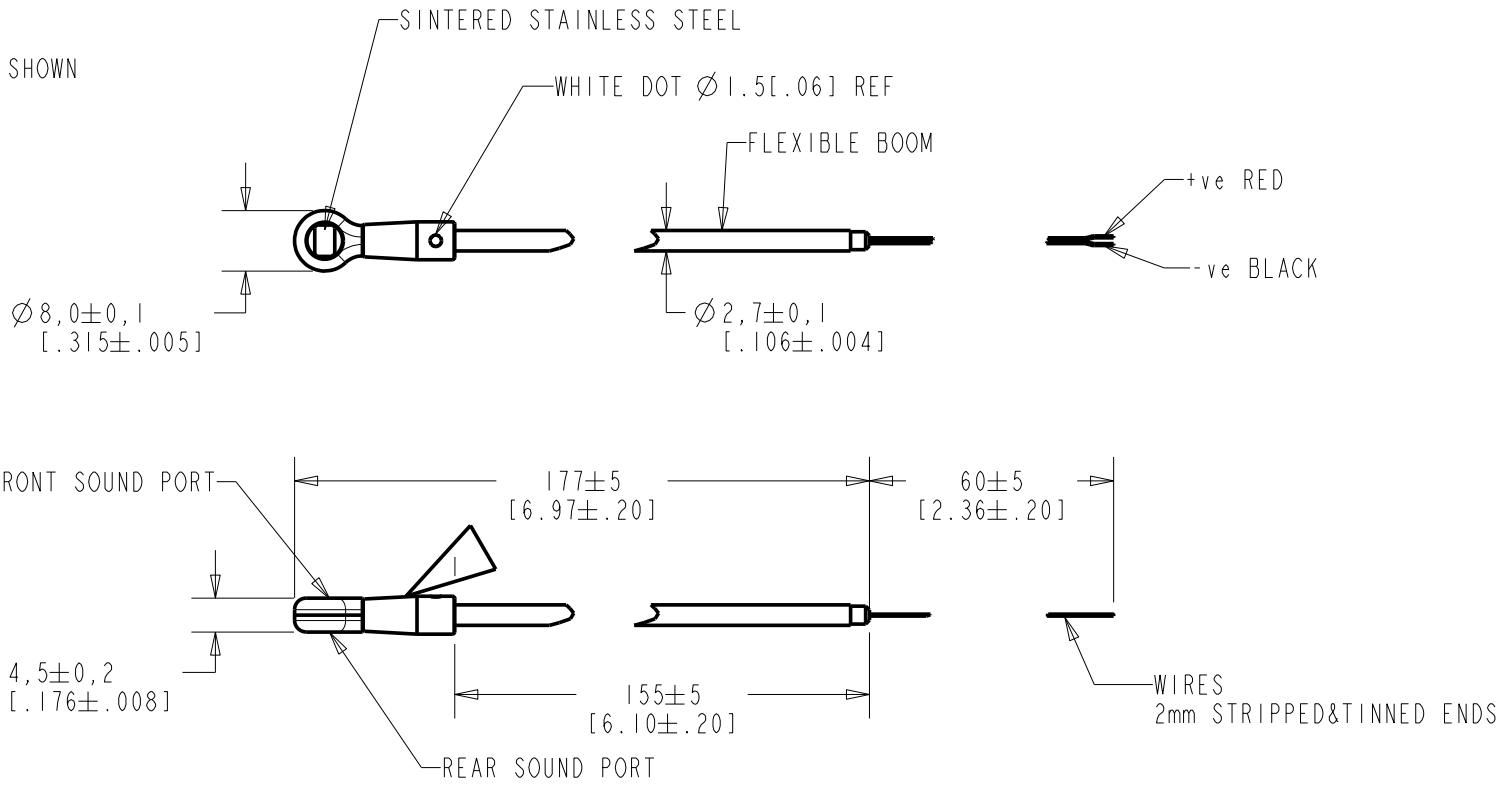

LENGTH	WIRE COLOR		WEIGHT GRAMS
	+ve	OUTPUT -ve	
	RED	BLACK	13.1

DIMENSIONS IN MILLIMETERS [INCHES]

Revision	C.O. #	Implementation Date	RELEASE LEVEL	REVISION
B	C10107741	7-18-08	Active	B
A	C10106619	3-4-08		

KNOWLES ELECTRONICS
ITASCA, ILLINOIS U.S.A.

SCALE: 1:1	DR. BY TT	DATE 3-4-08
DO NOT SCALE DRAWING	CK. BY GJP	DATE 3-9-08
TITLE: BOOM MICROPHONE FB-BW-30335-000	APP. BY GJP	DATE 3-9-08
OUTLINE DRAWING	SHT 1.1	

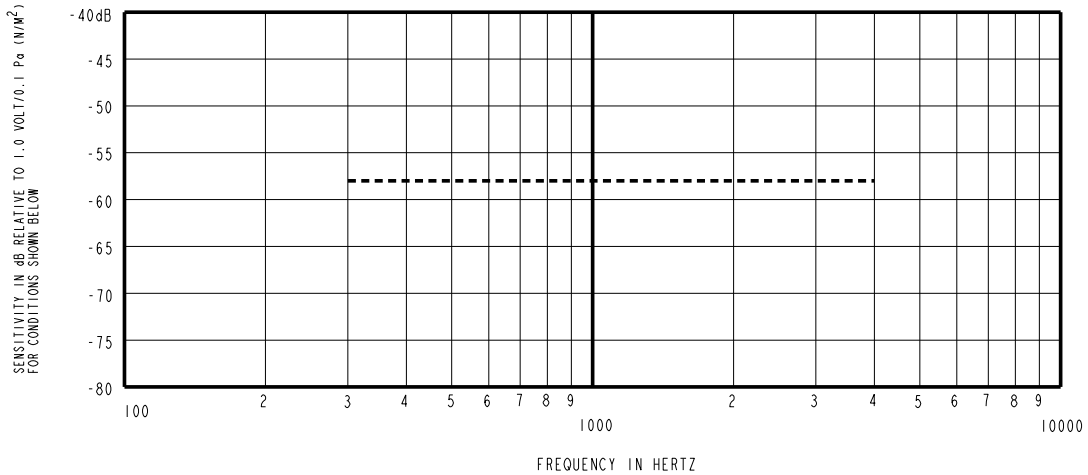

NOTES:

1. MICROPHONE TO BE FUNCTIONAL WITH 10 VDC SUPPLY.
2. SENSITIVITY VALUES INDICATED ON THIS SPECIFICATION ARE VALID AT 50% HUMIDITY.

3. SENSITIVITY

FREQUENCY	MIN	NOM	MAX
300	-63.0	-59.0	-55.0
1000	-63.0	-59.0	-55.0
4000	-63.0	-59.0	-55.0

4. TEST CONDITIONS:
HEAD OF BOOM EXPOSED TO 74 dB SPL SWEPT SOUND FIELD AT 6mm FROM VOICE APERTURE.
ARTIFICIAL VOICE: B & K 4227 MOUTH SIMULATOR.

5. FOR MICROPHONE CAPSULE SPEC. SEE WP-25993-D63 SHEET 2.1

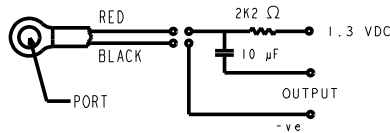
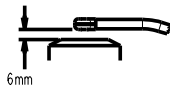

LEAD IDENTIFICATION & TEST CIRCUIT

Revision	C.O. #	Implementation Date	RELEASE LEVEL	REVISION
B	C10107741	7-18-08	Active	B
A	C10106619	3-4-08		

KNOWLES ELECTRONICS
ITASCA, ILLINOIS U.S.A.

WHEN TEST LIMITS ARE USED TO ESTABLISH INCOMING INSPECTION ACCEPTANCE/REJECTION CRITERIA, CORRELATION OF TEST EQUIPMENT WITH KNOWLES IS ALSO REQUIRED FOR ELIMINATION OF EQUIPMENT AND TEST METHOD VARIATION

TITLE: **BOOM MICROPHONE** **FB-BW-30335-000**
PERFORMANCE SPECIFICATION **SHT 2.1**

DR. BY	DATE
TT	3-4-08
CK. BY	DATE
GJP	3-9-08
APP. BY	DATE
GJP	3-9-08