

4-Bit Bus Switch with Individual Enables

Features

- Near-Zero propagation delay
- 5Ω switches connect inputs to outputs
- Direct bus connection when switches are ON
- Ultra Low Quiescent Power (0.1μA typical)
– Ideally suited for notebook applications
- Packaging (Pb-free & Green available):
– 16-pin 150-mil wide plastic QSOP (Q)

Description

Pericom Semiconductor's PI5C3125 and PI5C3126 are 4-bit Bus Switches designed with four individual 5Ω bus switches with fast individual enables in an industry standard 74XX125/126 pinout. When enabled via the associated Bus Enable (\overline{BE}) pin, the "A" pin is directly connected to the "B" pin for that particular gate. The bus switch introduces no additional propagation delay or additional ground bounce noise.

The PI5C3125 device has active LOW enables, and the PI5C3126 has active HIGH enables.

PI5C3125 Block Diagram

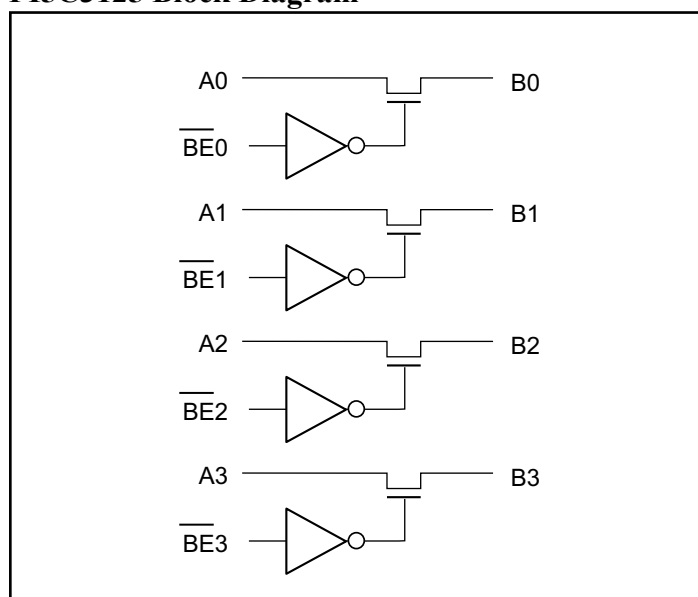

PI5C3126 Block Diagram

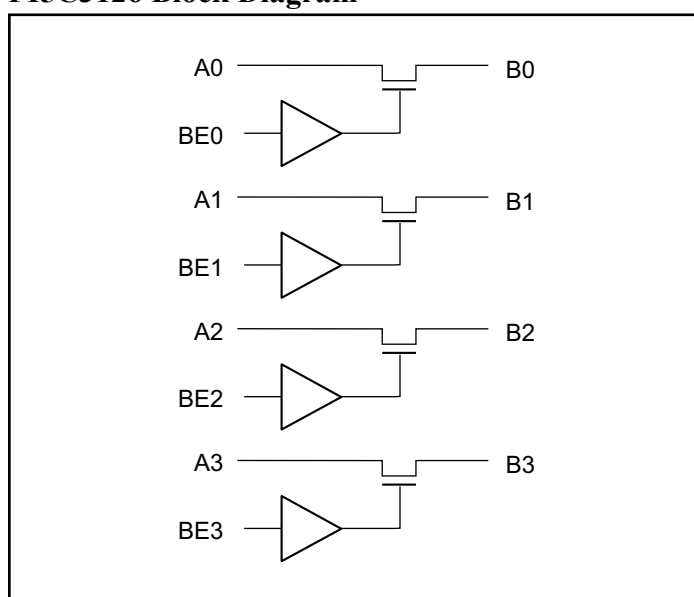

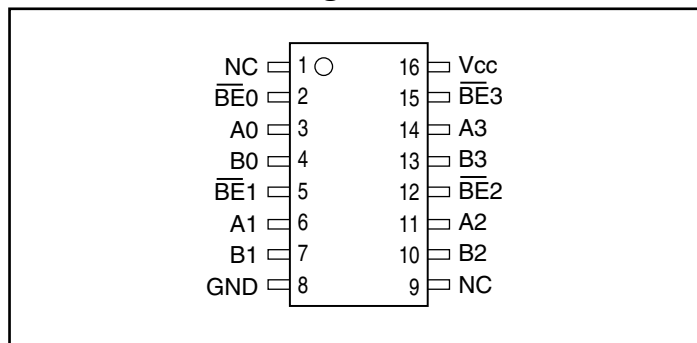
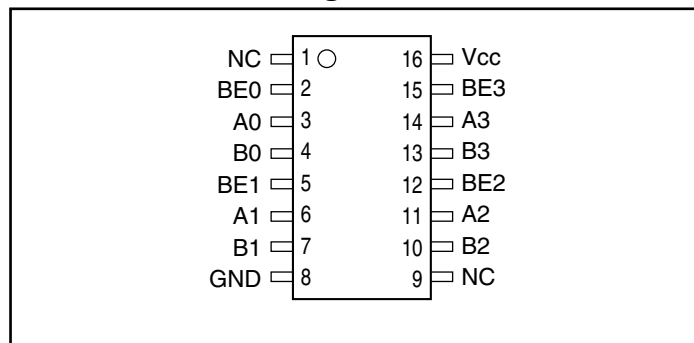
PI5C3125 16-Pin Configuration

PI5C3126 16-Pin Configuration

Pin Description

Pin Name	Description
$\overline{\text{BE}}_n$	Switch Enable (PI5C3125)
BE_n	Switch Enable (PI5C3126)
A3-A0	Bus A
B3-B0	Bus B
V_{CC}	Power
GND	Ground

Truth Table⁽¹⁾

PI5C3125 $\overline{\text{BE}}_n$	PI5C3126 BE_n	A_n	B_n	V_{CC}	Function
X ⁽²⁾	X	Hi-Z	Hi-Z	GND	Disconnect
H	L	Hi-Z	Hi-Z	V_{CC}	Disconnect
L	H	B_n	A_n	V_{CC}	Connect

Notes:

- H = High Voltage Level, L = Low Voltage Level, HI-Z = High Impedance, X = Don't Care
- A pull-up resistor should be provided for power-up protection.

Maximum Ratings

(Above which the useful life may be impaired. For user guidelines, not tested.)

Storage Temperature	-65°C to +150°C
Ambient Temperature with Power Applied	-40°C to +85°C
Supply Voltage to Ground Potential (Inputs & V_{CC} Only).....	-0.5V to +7.0V
Supply Voltage to Ground Potential (Outputs & D/O Only)	-0.5V to +7.0V
DC Input Voltage	-0.5V to +7.0V
DC Output Current.....	120mA
Power Dissipation.....	0.5W

Note:

Stresses greater than those listed under MAXIMUM RATINGS may cause permanent damage to the device. This is a stress rating only and functional operation of the device at these or any other conditions above those indicated in the operational sections of this specification is not implied. Exposure to absolute maximum rating conditions for extended periods may affect reliability.

DC Electrical Characteristics (Over the Operating Range, $T_A = -40^{\circ}\text{C}$ to $+85^{\circ}\text{C}$, $V_{CC} = 5\text{V} \pm 10\%$)

Parameters	Description	Test Conditions ⁽¹⁾		Min.	Typ ⁽²⁾	Max.	Units
V_{IH}	Input HIGH Voltage	Guaranteed Logic HIGH Level		2.0			V
V_{IL}	Input LOW Voltage	Guaranteed Logic LOW Level		-0.5		0.8	
I_{IH}	Input HIGH Current	$V_{CC} = \text{Max.}, V_{IN} = V_{CC}$				± 1	μA
I_{IL}	Input LOW Current	$V_{CC} = \text{Max.}, V_{IN} = \text{GND}$				± 1	
I_{OZH}	High Impedance Output Current	$0 \leq A, B \leq V_{CC}$				± 1	
V_{IK}	Clamp Diode Voltage	$V_{CC} = \text{Min.}, I_{IN} = -18\text{mA}$			-0.7	-1.2	V
I_{OS}	Short Circuit Current ⁽³⁾	A (B) = 0 V, B (A) = V_{CC}			100		mA
V_H	Input Hysteresis at Control Pins				150		mV
R_{ON}	Switch On-Resistance ⁽⁴⁾	$V_{CC} = \text{Min.}, V_{IN} = 0.0\text{V},$	$I_{ON} = 48\text{mA}$		5	7	Ω
		$V_{CC} = \text{Min.}, V_{IN} = 2.4\text{V},$	$I_{ON} = 15\text{mA}$		10	15	
		$V_{CC} = 4\text{V}, V_{IN} = 2.4\text{V},$	$I_{ON} = 15\text{mA}$	16	22		

Notes:

- For Max. or Min. conditions, use appropriate value specified under Electrical Characteristics for the applicable device type.
- Typical values are at $V_{CC} = 5.0\text{V}$, $T_A = 25^{\circ}\text{C}$ ambient and maximum loading.
- Not more than one output should be shorted at one time. Duration of the test should not exceed one second.
- Measured by the voltage drop between A and B pin at indicated current through the switch. ON resistance is determined by the lower of the voltages on the two (A, B) pins.

Capacitance ($T_A = 25^{\circ}\text{C}$, $f = 1\text{ MHz}$)

Parameters ⁽¹⁾	Description	Test Conditions	Typ.	Max.	Units
C_{IN}	Input Capacitance	$V_{IN} = 0\text{V}$		6	pF
C_{OFF}	A/B Capacitance, Switch Off			6	
C_{ON}	A/B Capacitance, Switch On			8	

Notes:

- This parameter is determined by device characterization but is not production tested.

Power Supply Characteristics

Parameters	Description	Test Conditions ⁽¹⁾		Min.	Typ ⁽²⁾	Max.	Units
I_{CC}	Quiescent Power Supply Current	$V_{CC} = \text{Max.}$	$V_{IN} = \text{GND}$ or V_{CC}		0.1	3.0	μA
ΔI_{CC}	Supply Current per Input @ TTL HIGH	$V_{CC} = \text{Max.}$	$V_{IN} = 3.4\text{V}^{(3)}$			2.5	mA
I_{CCD}	Supply Current per Input per MHz ⁽⁴⁾	$V_{CC} = \text{Max.},$ A and B Pins Open $\overline{\text{BEn}}/\text{BEn} = \text{GND}$ Control Input Toggling 50% Duty Cycle				0.25	mA/ MHz

Notes:

- For Max. or Min. conditions, use appropriate value specified under Electrical Characteristics for the applicable device.
- Typical values are at $V_{CC} = 5.0\text{V}$, $+25^{\circ}\text{C}$ ambient.
- Per TTL driven input ($V_{IN} = 3.4\text{V}$, control inputs only); A and B pins do not contribute to I_{CC} .
- This current applies to the control inputs only and represent the current required to switch internal capacitance at the specified frequency. The A and B inputs generate no significant AC or DC currents as they transition. This parameter is not tested, but is guaranteed by design.

Switching Characteristics over Operating Range

Parameters	Description	Conditions	Com.		Units
			Min.	Max.	
t _{PLH} t _{PHL}	Propagation Delay ^(1,2) A to B, B to A	C _L = 50pF R _L = 500Ω		0.25	ns
t _{PZH} t _{PZL}	Bus Enable Time		0.5	5.4	
t _{PLZ} t _{PHZ}	Bus Disable Time		0.5	4.7	

Notes:

1. This parameter is guaranteed but not tested on Propagation Delays.
2. The bus switch contributes no propagational delay other than the RC delay of the On-Resistance of the switch and the load capacitance. The time constant for the switch alone is of the order of 0.25ns for 50pF load. Since this time constant is much smaller than the rise/fall times of typical driving signals, it adds very little propagational delay to the system. Propagational delay of the bus switch when used in a system is determined by the driving circuit on the driving side of the switch and its interaction with the load on the driven side.

Packaging Mechanical: 16-Pin QSOP (Q)

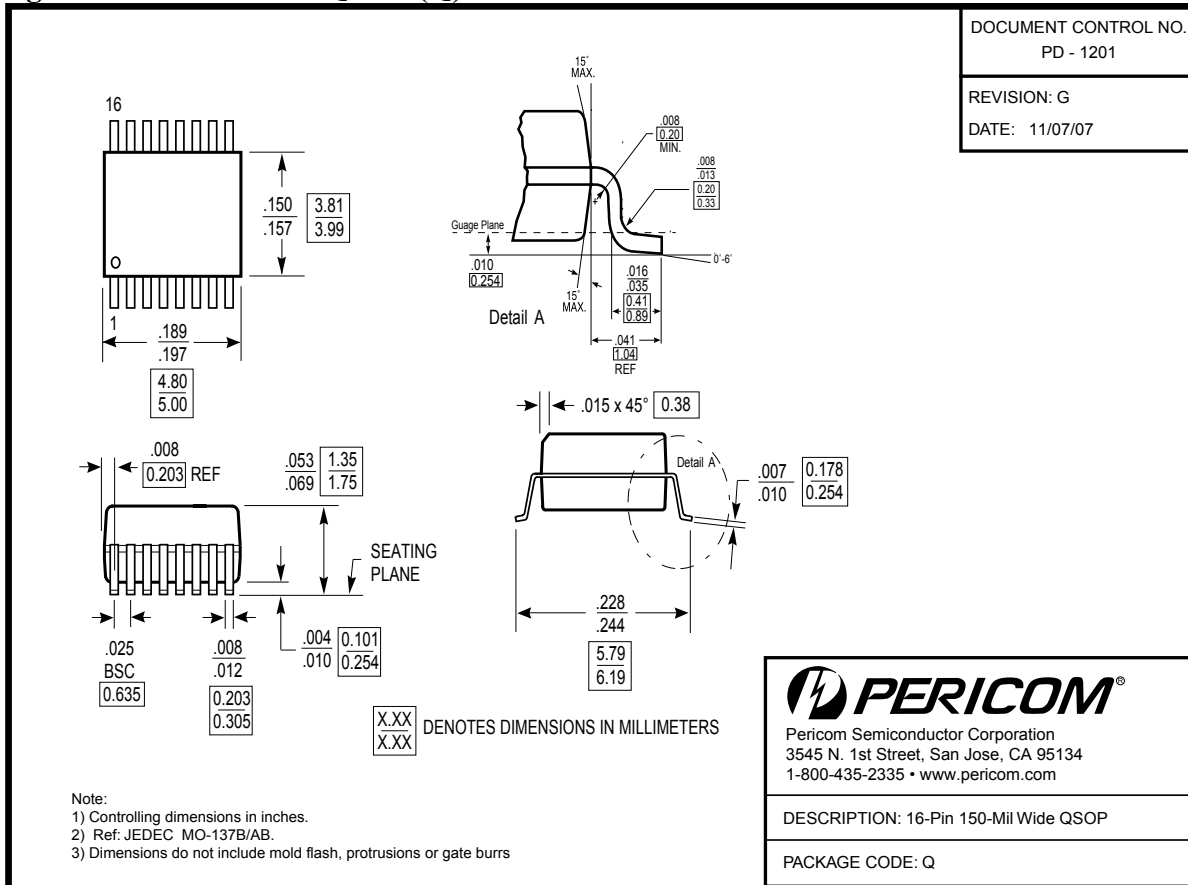

Ordering Information

Ordering Code	Package Type	Package Description
PI5C3125QE	Q	Pb-free & Green, 16-pin QSOP
PI5C3126QE	Q	Pb-free & Green, 16-pin QSOP

Notes:

- Thermal characteristics can be found on the company web site at www.pericom.com/packaging/
- E = Pb-free & Green
- Adding an X suffix = Tape/Reel