



LM4040/LM4041

Precision Micropower Shunt Voltage Reference

General Description

Ideal for space critical applications, the LM4040 and LM4041 precision voltage references are available in the subminiature (3mm × 1.3mm) SOT-23 surface-mount package.

The LM4040 is available in fixed reverse breakdown voltages of 2.500V, 4.096V, and 5.000V. The LM4041 is available with a fixed 1.225V or an adjustable reverse breakdown voltage.

The minimum operating current ranges from 60μA for the LM4041-1.2 to 74μA for the LM4040-5.0. LM4040 versions have a maximum operating current of 15mA. LM4041 versions have a maximum operating current of 12mA.

The LM4040 and LM4041 have bandgap reference temperature drift curvature correction and low dynamic impedance, ensuring stable reverse breakdown voltage accuracy over a wide range of operating temperatures and currents.

Datasheets and support documentation are available on Micrel's web site at: www.micrel.com.

Features

- Small SOT-23 package
- No output capacitor required
- Tolerates capacitive loads
- Fixed reverse breakdown voltages of 1.225, 2.500V, 4.096V, and 5.000V
- Adjustable reverse breakdown version
- Contact Micrel for parts with extended temperature range.

Applications

- Battery-powered equipment
- Data acquisition systems
- Instrumentation
- Process control
- Energy management
- Product testing
- Automotive electronics
- Precision audio components

Typical Application

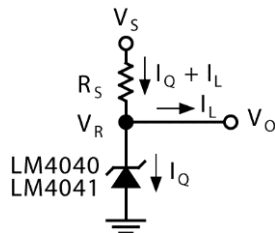

LM4040, LM4041 Fixed Shunt Regulator Application

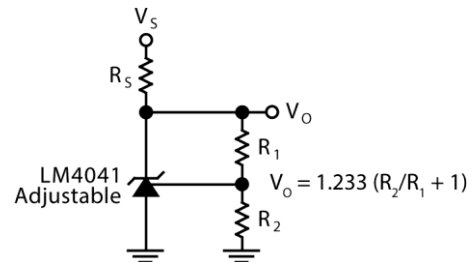

LM4041 Adjustable Shunt Regulator Application

Ordering Information

Part Number	Marking	Voltage	Accuracy, Temp. Coefficient	Package
LM4040CYM3-2.5	Y2C	2.500V	±0.5%, 100ppm/°C	3-Pin SOT-23
LM4040DYM3-2.5	Y2D	2.500V	±1.0%, 150ppm/°C	3-Pin SOT-23
LM4040CYM3-4.1	Y4C	4.096V	±0.5%, 100ppm/°C	3-Pin SOT-23
LM4040DYM3-4.1	Y4D	4.096V	±1.0%, 150ppm/°C	3-Pin SOT-23
LM4040CYM3-5.0	Y5C	5.000V	±0.5%, 100ppm/°C	3-Pin SOT-23
LM4040DYM3-5.0	Y5D	5.000V	±1.0%, 150ppm/°C	3-Pin SOT-23
LM4041CYM3-1.2	Y1C	1.225V	±0.5%, 100ppm/°C	3-Pin SOT-23
LM4041DYM3-1.2	Y1D	1.225V	±1.0%, 150ppm/°C	3-Pin SOT-23
LM4041CYM3-ADJ	YAC	1.24V to 10V	±0.5%, 100ppm/°C	3-Pin SOT-23
LM4041DYM3-ADJ	YAD	1.24V to 10V	±1.0%, 150ppm/°C	3-Pin SOT-23

Pin Configuration

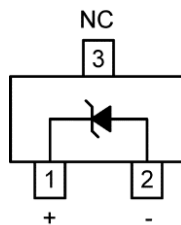

**SOT-23 (M3)
Fixed Version**

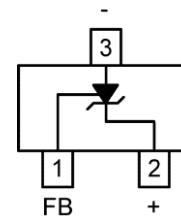

**SOT-23 (M3)
Adjustable Version**

Pin Description

Pin Number Fixed	Pin Number Adjustable	Pin Name	Pin Function
1	2	+	Cathode, connect to positive voltage.
-	1	FB	Feedback, connect to a resistive divider network to set the output voltage.
2	3	-	Anode, connect to negative voltage.
3	-	NC	Not internally connected. This pin must be left floating or connected to – (Pin 2).

Absolute Maximum Ratings⁽¹⁾

Reverse Current	20mA
Forward Current	10mA
Maximum Output Voltage (LM4041-ADJ)	15V
Lead Temperature	
Vapor phase (60s)	215°C
Infrared (15s)	220°C
Power Dissipation ($T_A = 25^\circ\text{C}$) ⁽³⁾	306mW
Storage Temperature (T_s).....	-65°C to +150°C
ESD Susceptibility	
Human Body Model ⁽⁴⁾	2kV
Machine Model ⁽⁴⁾	200V

Operating Ratings⁽²⁾

Operating Temperature Range (T_A).....	-40°C to +85°C
Reverse Current	
LM4040-2.5.....	60µA to 15mA
LM4040-4.1.....	68µA to 15mA
LM4040-5.0.....	74µA to 15mA
LM4041-1.2.....	60µA to 12mA
LM4041-ADJ.....	60µA to 12mA
Output Voltage Range	
LM4041-ADJ.....	1.24V to 10V
Thermal Resistance	
3-Pin SOT-23 (Θ_{JA}).....	326°C/W

LM4040-2.5 Electrical Characteristics⁽⁵⁾

T_A = Operating Temperature Range, **bold** values indicate $T_A = T_J = -40^\circ\text{C}$ to $+85^\circ\text{C}$, unless noted.

Symbol	Parameter	Condition	Min.	Typ.	Max.	Units
LM4040C						
V_R	Reverse Breakdown Voltage	$I_R = 100\mu\text{A}$		2.500		V
	Reverse Breakdown Voltage Tolerance ⁽⁶⁾				±12	mV
					±29	mV
I_{RMIN}	Minimum Operating Current			45	60	µA
					65	µA
$\Delta V_R/\Delta T$	Average Reverse Breakdown Voltage Temperature Coefficient	$I_R = 10\text{mA}$		±20		ppm/°C
		$I_R = 1\text{mA}$		±15	±100	ppm/°C
		$I_R = 100\mu\text{A}$		±15		ppm/°C
$\Delta V_R/\Delta I_R$	Reverse Breakdown Voltage Change with Operating Current Change	$I_{RMIN} \leq I_R \leq 1\text{mA}$		0.3	0.8	mV
					1.0	mV
		$1\text{mA} \leq I_R \leq 15\text{mA}$		2.5	6.0	mV
					8.0	mV
Z_R	Reverse Dynamic Impedance	$I_R = 1\text{mA}$, $f = 120\text{Hz}$, $I_{AC} = 0.1I_R$		0.3	0.9	Ω
e_N	Wideband Noise	$I_R = 100\mu\text{A}$, $10\text{Hz} \leq f \leq 10\text{kHz}$		35		µV _{RMS}
ΔV_R	Reverse Breakdown Voltage Long Term Stability	$t = 1000\text{hrs.}$, $T = 25^\circ\text{C} \pm 0.1^\circ\text{C}$, $I_R = 100\mu\text{A}$		120		ppm

Notes:

- Exceeding the absolute maximum ratings may damage the device.
- The device is not guaranteed to function outside its operating ratings.
- The maximum power dissipation must be derated at elevated temperatures and is dictated by T_{JMAX} (maximum junction temperature), Θ_{JA} (junction to ambient thermal resistance), and T_A (ambient temperature). The maximum allowable power dissipation at any temperature is $P_{DMAX} = (T_{JMAX} - T_A) / \Theta_{JA}$ or the number given in the Absolute Maximum Ratings, whichever is lower. For the LM4040 and LM4041, $T_{JMAX} = 125^\circ\text{C}$ and the typical thermal resistance, when board-mounted, is 326°C/W for the SOT-23 package.
- Devices are ESD sensitive. Handling precautions are recommended. Human body model, 1.5kΩ in series with 100pF. The machine model is a 200pF capacitor discharged directly into each pin.
- Specification for packaged product only.
- The boldface (overtemperature) limit for Reverse Breakdown Voltage Tolerance is defined as the room temperature Reverse Breakdown Voltage Tolerance $\pm[(\Delta V_R/\Delta T)(65^\circ\text{C})(V_R)]$. $\Delta V_R/\Delta T$ is the V_R temperature coefficient, 65°C is the temperature range from -40°C to the reference point of 25°C, and V_R is the reverse breakdown voltage. The total overtemperature tolerance for the different grades follows:
 - C-grade: $\pm 1.15\% = \pm 0.5\% \pm 100\text{ppm}/^\circ\text{C} \times 65^\circ\text{C}$
 - D-grade: $\pm 1.98\% = \pm 1.0\% \pm 150\text{ppm}/^\circ\text{C} \times 65^\circ\text{C}$
 Example: The C-grade LM4040-2.5 has an overtemperature Reverse Breakdown Voltage tolerance of $\pm 2.5 \times 1.15\% = \pm 29\text{mV}$.

LM4040-2.5 Electrical Characteristics⁽⁵⁾ (Continued)

T_A = Operating Temperature Range, **bold** values indicate T_A = T_J = -40°C to +85°C, unless noted.

Symbol	Parameter	Condition	Min.	Typ.	Max.	Units
LM4040D						
V _R	Reverse Breakdown Voltage	I _R = 100μA		2.500		V
	Reverse Breakdown Voltage Tolerance ⁽⁶⁾				±25	mV
					±49	mV
I _{RMIN}	Minimum Operating Current			45	65	μA
					70	μA
ΔV _R /ΔT	Average Reverse Breakdown Voltage Temperature Coefficient	I _R = 10mA		±20		ppm/°C
		I _R = 1mA		±15	±150	ppm/°C
		I _R = 100μA		±15		ppm/°C
ΔV _R /ΔI _R	Reverse Breakdown Voltage Change with Operating Current Change	I _{RMIN} ≤ I _R ≤ 1mA		0.3	1.0	mV
					1.2	mV
		1mA ≤ I _R ≤ 15mA		2.5	8.0	mV
					10.0	mV
Z _R	Reverse Dynamic Impedance	I _R = 1mA, f = 120Hz, I _{AC} = 0.1I _R		0.3	1.1	Ω
e _N	Wideband Noise	I _R = 100μA, 10Hz ≤ f ≤ 10kHz		35		μV _{RMS}
ΔV _R	Reverse Breakdown Voltage Long Term Stability	t = 1000hrs., T = 25°C ±0.1°C, I _R = 100μA		120		ppm

LM4040-4.1 Electrical Characteristics⁽⁵⁾

T_A = Operating Temperature Range, **bold** values indicate T_A = T_J = -40°C to +85°C, unless noted.

Symbol	Parameter	Condition	Min.	Typ.	Max.	Units
LM4040C						
V _R	Reverse Breakdown Voltage	I _R = 100μA		4.096		V
	Reverse Breakdown Voltage Tolerance ⁽⁶⁾				±20	mV
					±47	mV
I _{RMIN}	Minimum Operating Current			50	68	μA
					73	μA
ΔV _R /ΔT	Average Reverse Breakdown Voltage Temperature Coefficient	I _R = 10mA		±30		ppm/°C
		I _R = 1mA		±20	±100	ppm/°C
		I _R = 100μA		±20		ppm/°C
ΔV _R /ΔI _R	Reverse Breakdown Voltage Change with Operating Current Change	I _{RMIN} ≤ I _R ≤ 1mA		0.5	0.9	mV
					1.2	mV
		1mA ≤ I _R ≤ 15mA		3.0	7.0	mV
					10.0	mV
Z _R	Reverse Dynamic Impedance	I _R = 1mA, f = 120Hz, I _{AC} = 0.1I _R		0.5	1.0	Ω
e _N	Wideband Noise	I _R = 100μA, 10Hz ≤ f ≤ 10kHz		80		μV _{RMS}
ΔV _R	Reverse Breakdown Voltage Long Term Stability	t = 1000hrs., T = 25°C ±0.1°C, I _R = 100μA		120		ppm

LM4040-4.1 Electrical Characteristics⁽⁵⁾ (Continued)

T_A = Operating Temperature Range, **bold** values indicate T_A = T_J = -40°C to +85°C, unless noted.

Symbol	Parameter	Condition	Min.	Typ.	Max.	Units
LM4040D						
V _R	Reverse Breakdown Voltage	I _R = 100μA		4.096		V
	Reverse Breakdown Voltage Tolerance ⁽⁶⁾				±41	mV
						±81
I _{RMIN}	Minimum Operating Current			50	73	μA
					78	μA
ΔV _R /ΔT	Average Reverse Breakdown Voltage Temperature Coefficient	I _R = 10mA		±30		ppm/°C
		I _R = 1mA		±20	±150	ppm/°C
		I _R = 100μA		±20		ppm/°C
ΔV _R /ΔI _R	Reverse Breakdown Voltage Change with Operating Current Change	I _{RMIN} ≤ I _R ≤ 1mA		0.5	1.2	mV
					1.5	mV
		1mA ≤ I _R ≤ 15mA		3.0	9.0	mV
					13.0	mV
Z _R	Reverse Dynamic Impedance	I _R = 1mA, f = 120Hz, I _{AC} = 0.1I _R		0.5	1.3	Ω
e _N	Wideband Noise	I _R = 100μA, 10Hz ≤ f ≤ 10kHz		80		μV _{RMS}
ΔV _R	Reverse Breakdown Voltage Long Term Stability	t = 1000hrs., T = 25°C ±0.1°C, I _R = 100μA		120		ppm

LM4040-5.0 Electrical Characteristics⁽⁵⁾

T_A = Operating Temperature Range, **bold** values indicate T_A = T_J = -40°C to +85°C, unless noted.

Symbol	Parameter	Condition	Min.	Typ.	Max.	Units
LM4040C						
V _R	Reverse Breakdown Voltage	I _R = 100μA		5.000		V
	Reverse Breakdown Voltage Tolerance ⁽⁶⁾				±25	mV
						±58
I _{RMIN}	Minimum Operating Current			54	74	μA
					80	μA
ΔV _R /ΔT	Average Reverse Breakdown Voltage Temperature Coefficient	I _R = 10mA		±30		ppm/°C
		I _R = 1mA		±20	±100	ppm/°C
		I _R = 100μA		±20		ppm/°C
ΔV _R /ΔI _R	Reverse Breakdown Voltage Change with Operating Current Change	I _{RMIN} ≤ I _R ≤ 1mA		0.5	1.0	mV
					1.4	mV
		1mA ≤ I _R ≤ 15mA		3.5	8.0	mV
					12.0	mV
Z _R	Reverse Dynamic Impedance	I _R = 1mA, f = 120Hz, I _{AC} = 0.1I _R		0.5	1.1	Ω
e _N	Wideband Noise	I _R = 100μA, 10Hz ≤ f ≤ 10kHz		80		μV _{RMS}
ΔV _R	Reverse Breakdown Voltage Long Term Stability	t = 1000hrs., T = 25°C ±0.1°C, I _R = 100μA		120		ppm

LM4040-5.0 Electrical Characteristics⁽⁵⁾ (Continued)

T_A = Operating Temperature Range, **bold** values indicate T_A = T_J = -40°C to +85°C, unless noted.

Symbol	Parameter	Condition	Min.	Typ.	Max.	Units
LM4040D						
V _R	Reverse Breakdown Voltage	I _R = 100μA		5.000		V
	Reverse Breakdown Voltage Tolerance ⁽⁶⁾				±50	mV
						±99
I _{RMIN}	Minimum Operating Current			54	79	μA
					85	μA
ΔV _R /ΔT	Average Reverse Breakdown Voltage Temperature Coefficient	I _R = 10mA		±30		ppm/°C
		I _R = 1mA		±20	±150	ppm/°C
		I _R = 100μA		±20		ppm/°C
ΔV _R /ΔI _R	Reverse Breakdown Voltage Change with Operating Current Change	I _{RMIN} ≤ I _R ≤ 1mA		0.5	1.3	mV
					1.8	mV
		1mA ≤ I _R ≤ 15mA		3.5	10.0	mV
					15.0	mV
Z _R	Reverse Dynamic Impedance	I _R = 1mA, f = 120Hz, I _{AC} = 0.1I _R		0.5	1.5	Ω
e _N	Wideband Noise	I _R = 100μA, 10Hz ≤ f ≤ 10kHz		80		μV _{RMS}
ΔV _R	Reverse Breakdown Voltage Long Term Stability	t = 1000hrs., T = 25°C ±0.1°C, I _R = 100μA		120		ppm

LM4041-1.2 Electrical Characteristics⁽⁵⁾

T_A = Operating Temperature Range, **bold** values indicate T_A = T_J = -40°C to +85°C, unless noted.

Symbol	Parameter	Condition	Min.	Typ.	Max.	Units
LM4041C						
V _R	Reverse Breakdown Voltage	I _R = 100μA		1.225		V
	Reverse Breakdown Voltage Tolerance ⁽⁶⁾				±6	mV
						±14
I _{RMIN}	Minimum Operating Current			45	60	μA
					65	μA
ΔV _R /ΔT	Average Reverse Breakdown Voltage Temperature Coefficient	I _R = 10mA		±20		ppm/°C
		I _R = 1mA		±15	±100	ppm/°C
		I _R = 100μA		±15		ppm/°C
ΔV _R /ΔI _R	Reverse Breakdown Voltage Change with Operating Current Change	I _{RMIN} ≤ I _R ≤ 1mA		0.7	1.5	mV
					2.0	mV
		1mA ≤ I _R ≤ 15mA		4.0	6.0	mV
					8.0	mV
Z _R	Reverse Dynamic Impedance	I _R = 1mA, f = 120Hz, I _{AC} = 0.1I _R		0.5	1.5	Ω
e _N	Wideband Noise	I _R = 100μA, 10Hz ≤ f ≤ 10kHz		20		μV _{RMS}
ΔV _R	Reverse Breakdown Voltage Long Term Stability	t = 1000hrs., T = 25°C ±0.1°C, I _R = 100μA		120		ppm

LM4041-1.2 Electrical Characteristics⁽⁵⁾ (Continued)

T_A = Operating Temperature Range, **bold** values indicate T_A = T_J = -40°C to +85°C, unless noted.

Symbol	Parameter	Condition	Min.	Typ.	Max.	Units
LM4041D						
V _R	Reverse Breakdown Voltage	I _R = 100μA		1.225		V
	Reverse Breakdown Voltage Tolerance ⁽⁶⁾				±12	mV
					±24	mV
I _{RMIN}	Minimum Operating Current			45	65	μA
					70	μA
ΔV _R /ΔT	Average Reverse Breakdown Voltage Temperature Coefficient	I _R = 10mA		±20		ppm/°C
		I _R = 1mA		±15	±150	ppm/°C
		I _R = 100μA		±15		ppm/°C
ΔV _R /ΔI _R	Reverse Breakdown Voltage Change with Operating Current Change	I _{RMIN} ≤ I _R ≤ 1mA		0.7	2.0	mV
					2.5	mV
		1mA ≤ I _R ≤ 15mA		2.5	8.0	mV
					10.0	mV
Z _R	Reverse Dynamic Impedance	I _R = 1mA, f = 120Hz, I _{AC} = 0.1I _R		0.5	2.0	Ω
e _N	Wideband Noise	I _R = 100μA, 10Hz ≤ f ≤ 10kHz		20		μV _{RMS}
ΔV _R	Reverse Breakdown Voltage Long Term Stability	t = 1000hrs., T = 25°C ±0.1°C, I _R = 100μA		120		ppm

LM4041-ADJ Electrical Characteristics⁽⁵⁾

T_A = Operating Temperature Range, **bold** values indicate T_A = T_J = -40°C to +85°C, unless noted.

Symbol	Parameter	Condition	Min.	Typ.	Max.	Units
LM4041C						
V _R	Reverse Breakdown Voltage	I _R = 100μA, V _{OUT} = 5V		1.233		V
	Reverse Breakdown Voltage Tolerance ⁽⁶⁾	I _R = 100μA			±6.2	mV
					±14	mV
I _{RMIN}	Minimum Operating Current			45	60	μA
					65	μA
ΔV _{REF} /ΔI _R	Reference Voltage Change with Operating Current	I _{RMIN} ≤ I _R ≤ 1mA, V _{OUT} ≥ 1.6V ⁽⁷⁾		0.7	1.5	mV
					2.0	mV
		1mA ≤ I _R ≤ 15mA, V _{OUT} ≥ 1.6V ⁽⁷⁾		2.0	4.0	mV
					6.0	mV
ΔV _{REF} /ΔV _O	Reference Voltage Change with Output Voltage Change	I _R = 1mA		-1.55	-2.0	mV/V
					-2.5	mV/V
I _{FB}	Feedback Current			60	100	nA
					120	nA
ΔV _{REF} /ΔT	Average Reference Voltage Temperature Coefficient	V _{OUT} = 5V, I _R = 10mA		±20		ppm/°C
		V _{OUT} = 5V, I _R = 1mA		±15	±100	ppm/°C
		V _{OUT} = 5V, I _R = 100μA		±15		ppm/°C
Z _{OUT}	Dynamic Output Impedance	I _R = 1mA, f = 120Hz, I _{AC} = 0.1I _R V _{OUT} = V _{REF}		0.3		Ω
		V _{OUT} = 10V			2.0	Ω
e _N	Wideband Noise	I _R = 100μA, 10Hz ≤ f ≤ 10kHz		20		μV _{RMS}
ΔV _R	Reverse Breakdown Voltage Long Term Stability	t = 1000hrs, T = 25°C ±0.1°C, I _R = 100μA		120		ppm

Note:

7. When V_{OUT} ≤ 1.6V, the LM4041-ADJ must operate at reduced I_R. This is caused by the series resistance of the die attach between the die (-) output and the package (-) output pin. See the Output Saturation curve in the "Typical Performance Characteristics" section.

LM4041-ADJ Electrical Characteristics⁽⁵⁾

T_A = Operating Temperature Range, **bold** values indicate T_A = T_J = -40°C to +85°C, unless noted.

Symbol	Parameter	Condition	Min.	Typ.	Max.	Units
LM4041D						
V _R	Reverse Breakdown Voltage	I _R = 100μA, V _{OUT} = 5V		1.233		V
	Reverse Breakdown Voltage Tolerance ⁽⁶⁾	I _R = 100μA			±12	mV
I _{RMIN}	Minimum Operating Current			45	65	μA
					70	μA
ΔV _{REF} / ΔI _R	Reference Voltage Change with Operating Current	I _{RMIN} ≤ I _R ≤ 1mA, V _{OUT} ≥ 1.6V ⁽⁷⁾		0.7	2.0	mV
					2.5	mV
		1mA ≤ I _R ≤ 15mA, V _{OUT} ≥ 1.6V ⁽⁷⁾		2.0	6.0	mV
ΔV _{REF} / ΔV _O	Reference Voltage Change with Output Voltage Change	I _R = 1mA		-1.55	-2.5	mV/V
					-3.0	mV/V
I _{FB}	Feedback Current			60	150	nA
					200	nA
ΔV _{REF} /ΔT	Average Reference Voltage Temperature Coefficient	V _{OUT} = 5V, I _R = 10mA		±20		ppm/°C
		V _{OUT} = 5V, I _R = 1mA		±15	±150	ppm/°C
		V _{OUT} = 5V, I _R = 100μA		±15		ppm/°C
Z _{OUT}	Dynamic Output Impedance	I _R = 1mA, f = 120Hz, I _{AC} = 0.1I _R V _{OUT} = V _{REF}		0.3		Ω
		V _{OUT} = 10V			2.0	Ω
e _N	Wideband Noise	I _R = 100μA, 10Hz ≤ f ≤ 10kHz		20		μV _{RMS}
ΔV _R	Reverse Breakdown Voltage Long Term Stability	t = 1000hrs, T = 25°C ±0.1°C, I _R = 100μA		120		ppm

Test Circuit

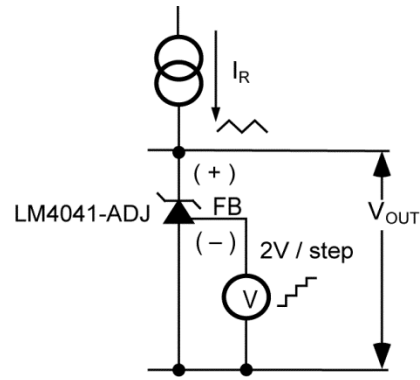
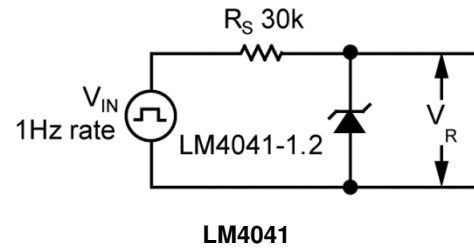
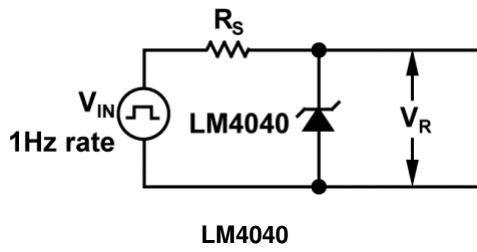

Reverse Characteristics Test Circuit

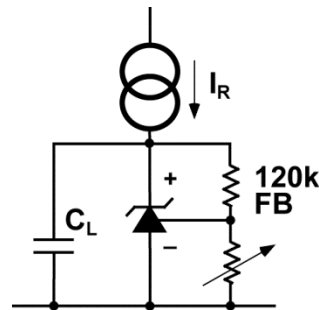

Output Impedance vs. Frequency Test Circuit

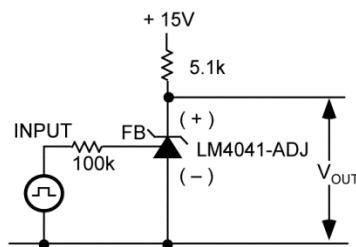

Large Signal Response Test Circuit

LM4040 Typical Characteristics

Output Impedance vs. Frequency

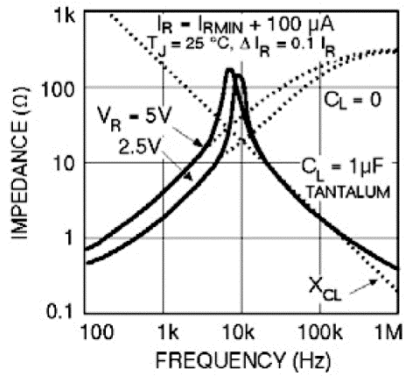

Output Impedance vs. Frequency

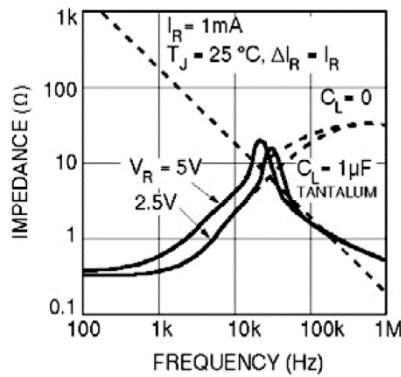

Reverse Characteristics and Minimum Operating Current

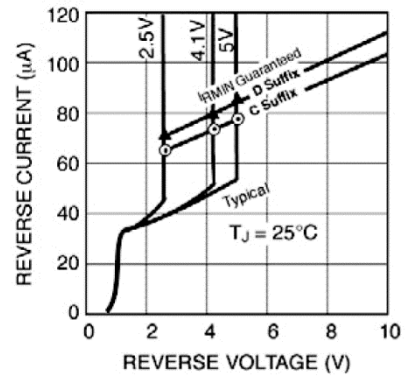

Noise Voltage vs. Frequency

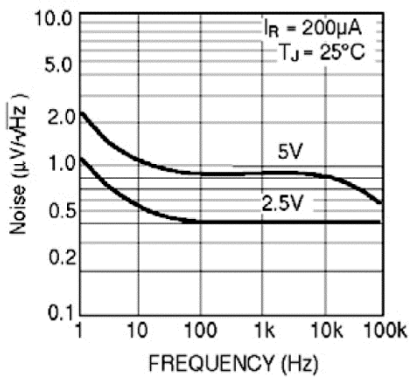

Start-up Characteristics LM4040-2.5 R_S = 30k

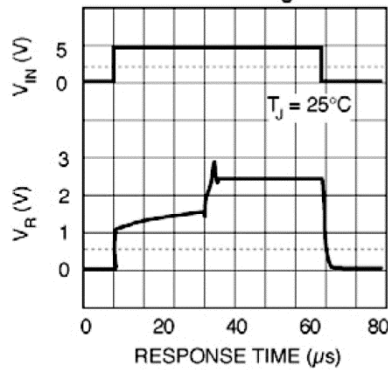

Start-up Characteristics LM4040-5.0 R_S = 30k

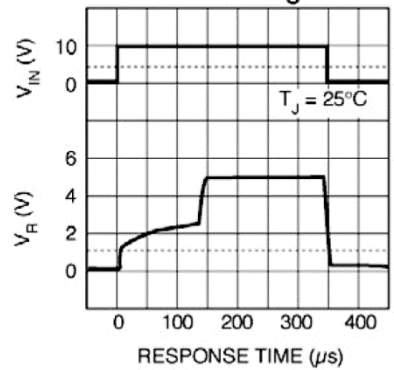

LM4041 Typical Characteristics

Noise Voltage vs. Frequency

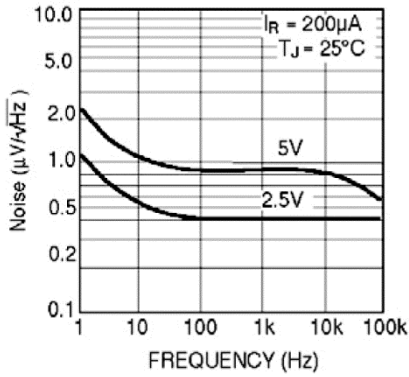

Output Saturation

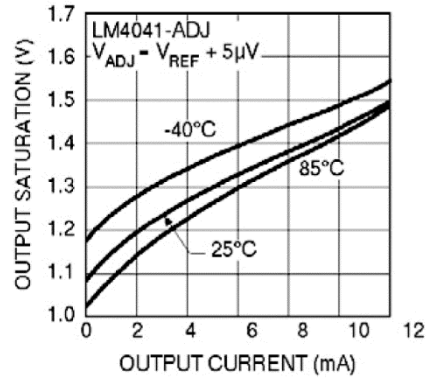

Output Impedance vs. Frequency *

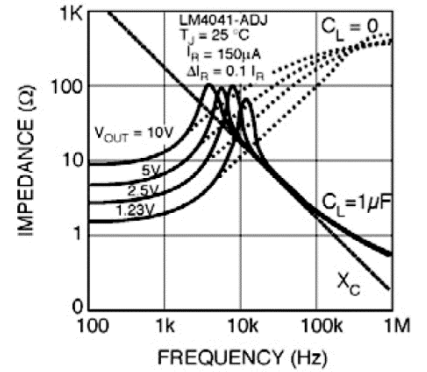

Large Signal Response ‡

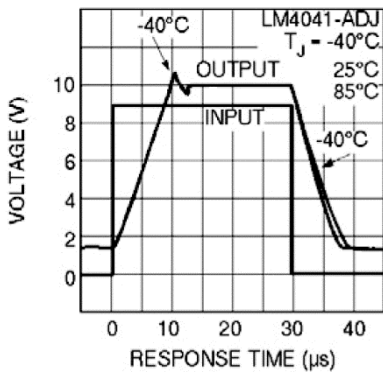

Functional Diagrams

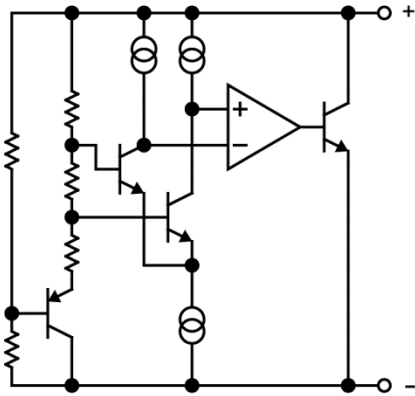

LM4040, LM4041 Fixed

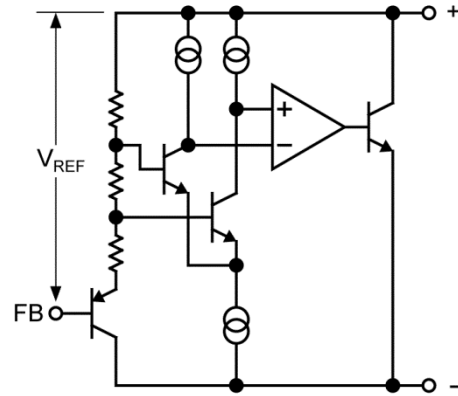

LM4041 Adjustable

Applications Information

The stable operation of the LM4040 and LM4041 references requires an external capacitor greater than 10nF connected between the (+) and (–) pins. Bypass capacitors with values between 100pF and 10nF have been found to cause the devices to exhibit instabilities.

Schottky Diode

LM4040-x.x and LM4041-1.2 in the SOT-23 package have a parasitic Schottky diode between pin 2 (–) and pin 3 (die attach interface connect). Pin 3 of the SOT-23 package must float or be connected to pin 2. The LM4041-ADJs use pin 3 as the (–) output.

Conventional Shunt Regulator

In a conventional shunt regulator application (see Figure 1), an external series resistor (R_S) is connected between the supply voltage and the LM4040-x.x or LM4041-1.2 reference. R_S determines the current that flows through the load (I_L) and the reference (I_Q). Because load current and supply voltage may vary, R_S should be small enough to supply at least the minimum acceptable I_Q to the reference even when the supply voltage is at its minimum and the load current is at its maximum value. When the supply voltage is at its maximum and I_L is at its minimum, R_S should be large enough so that the current flowing through the LM4040-x.x is less than 15mA, and the current flowing through the LM4041-1.2 or LM4041-ADJ is less than 12mA.

R_S is determined by the supply voltage (V_S), the load and operating current, (I_L and I_Q), and the reference's reverse breakdown voltage (V_R):

$$R_S = (V_S - V_R) / (I_L + I_Q) \quad \text{Eq. 1}$$

Adjustable Regulator

The LM4041-ADJ's output voltage can be adjusted to any value in the range of 1.24V through 10V. It is a function of the internal reference voltage (V_{REF}) and the ratio of the external feedback resistors as shown in Figure 2. The output is found using the following equation:

$$V_O = V_{REF} [(R_2/R_1) + 1] \quad \text{Eq. 2}$$

where V_O is the desired output voltage. The actual value of the internal V_{REF} is a function of V_O . The corrected V_{REF} is determined by:

$$V_{REF} = V_O (\Delta V_{REF}/\Delta V_O) + V_Y \quad \text{Eq. 3}$$

where V_O is the desired output voltage. $\Delta V_{REF}/\Delta V_O$ is found in the Electrical Characteristics section and is typically -1.3mV/V and V_Y is equal to 1.233V. Replace the value of V_{REF} in Equation 2 with the value V_{REF} found using Equation 3.

Note that actual output voltage can deviate from that predicted using the typical $\Delta V_{REF}/\Delta V_O$ in Equation 3; for C-grade parts, the worst-case $\Delta V_{REF}/\Delta V_O$ is -2.5mV/V and $V_Y = 1.248\text{V}$.

The following example shows the difference in output voltage resulting from the typical and worst case values of $\Delta V_{REF}/\Delta V_O$.

Let $V_O = +9\text{V}$. Using the typical values of $\Delta V_{REF}/\Delta V_O$, V_{REF} is 1.223V. Choosing a value of $R_1 = 10\text{k}\Omega$, $R_2 = 63.272\text{k}\Omega$. Using the worst case $\Delta V_{REF}/\Delta V_O$ for the C-grade and D-grade parts, the output voltage is actually 8.965V and 8.946V respectively. This results in possible errors as large as 0.39% for the C-grade parts and 0.59% for the D-grade parts. Once again, resistor values found using the typical value of $\Delta V_{REF}/\Delta V_O$ will work in most cases, requiring no further adjustment.

Typical Application Circuits

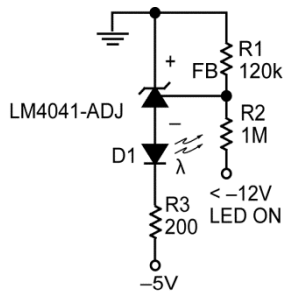

Figure 1. Voltage Level Detector

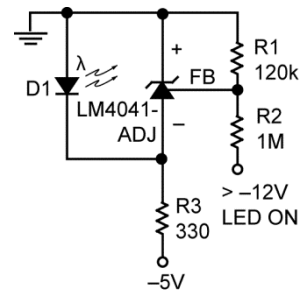

Figure 2. Voltage Level Detector

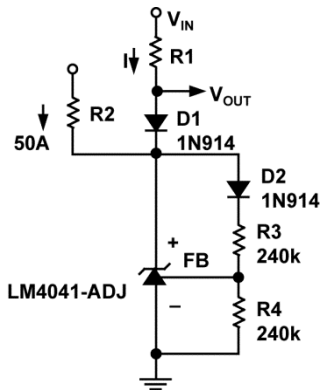

Figure 3. Fast Positive Clamp
 $2.4V + \Delta V_{D1}$

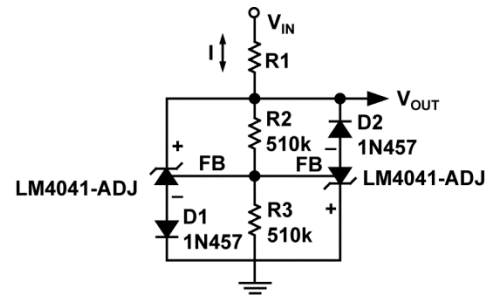

Figure 4. Bidirectional Clamp
 $\pm 2.4V$

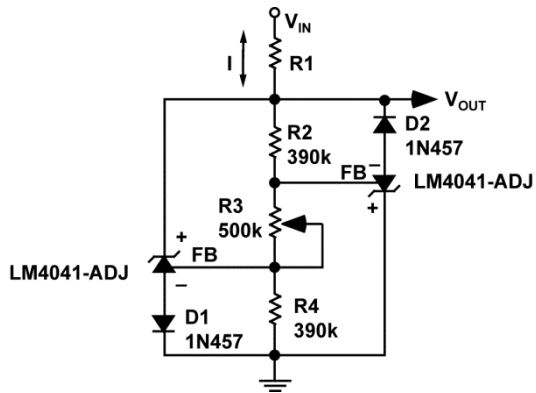

Figure 5. Bidirectional Adjustable Clamp
 $\pm 18V$ to $\pm 2.4V$

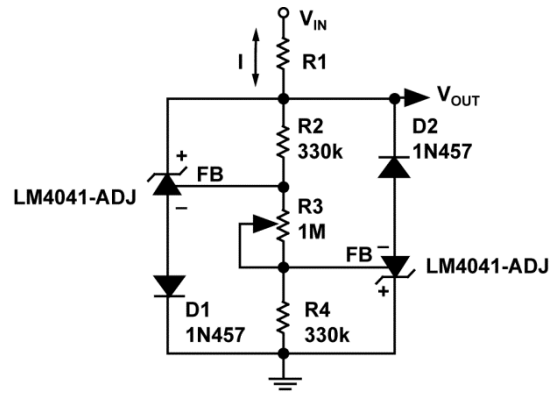
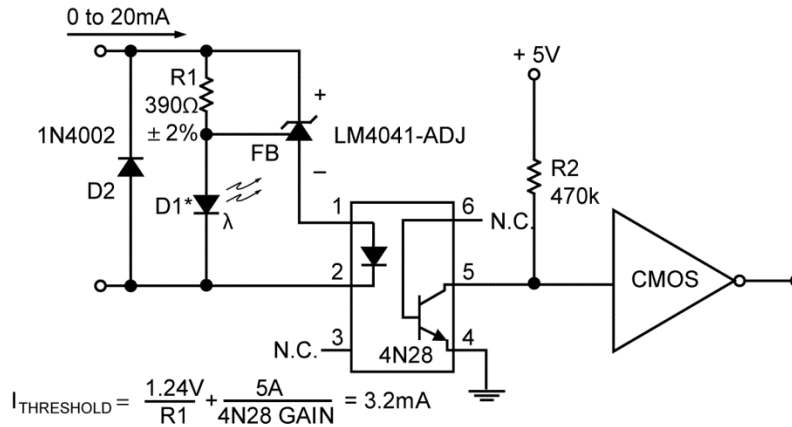

Figure 6. Bidirectional Adjustable Clamp
 $\pm 2.4V$ to $\pm 6V$

Typical Application Circuits (Continued)



* D1 can be any LED, $V_F = 1.5\text{V to } 2.2\text{V}$ at 3mA . D1 may act as an indicator. D1 will be on if $I_{\text{THRESHOLD}}$ falls below the threshold current, except with $I = 0$.

Figure 7. Floating Current Detector

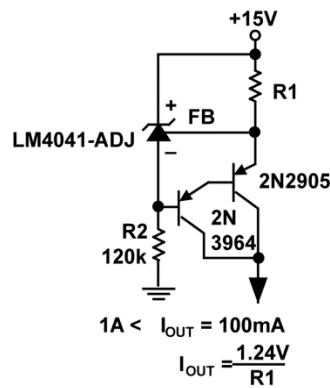
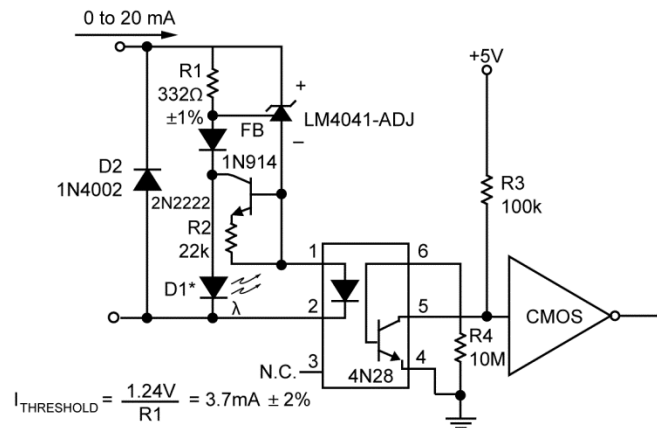

Figure 8. Current Source



* D1 can be any LED, $V_F = 1.5\text{V to } 2.2\text{V}$ at 3mA . D1 may act as an indicator. D1 will be on if $I_{\text{THRESHOLD}}$ falls below the threshold current, except with $I = 0$.

Figure 9. Precision Floating Current Detector

Package Information⁽⁸⁾

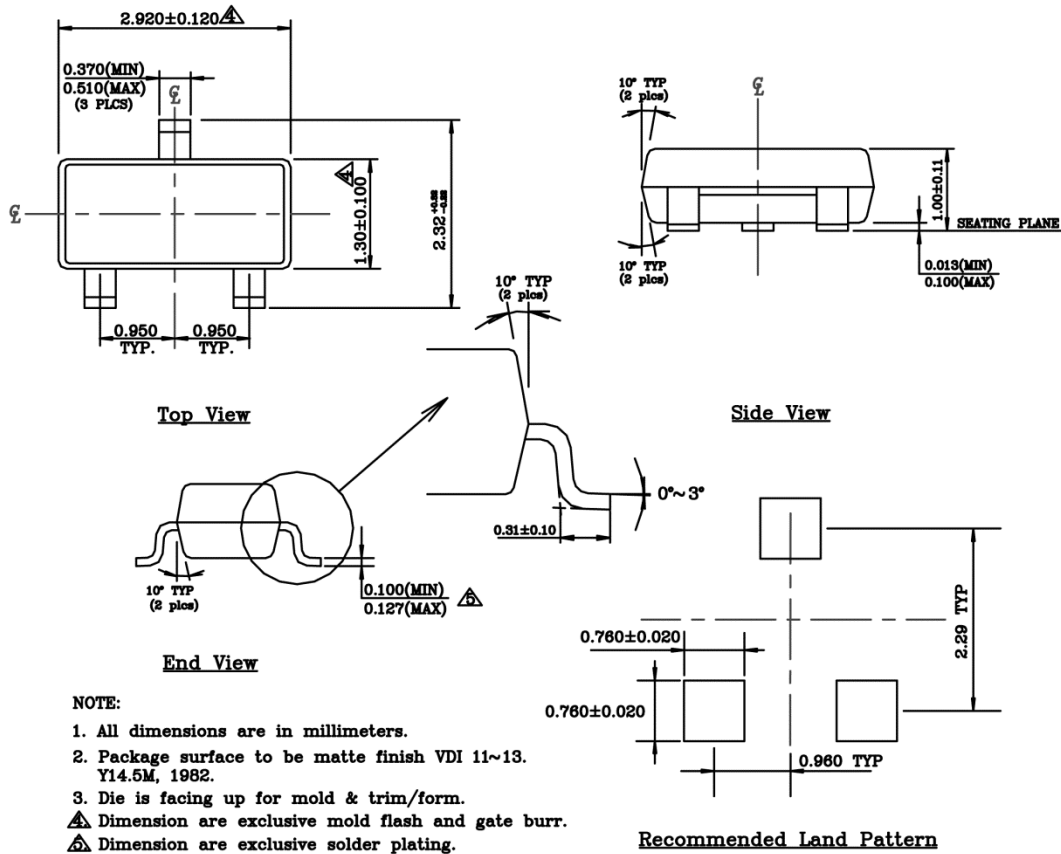

3-Pin SOT-23 (M3)

Note:

8. Package information is correct as of the publication date. For updates and most current information, go to www.micrel.com.

MICREL, INC. 2180 FORTUNE DRIVE SAN JOSE, CA 95131 USA
 TEL +1 (408) 944-0800 FAX +1 (408) 474-1000 WEB <http://www.micrel.com>

Micrel makes no representations or warranties with respect to the accuracy or completeness of the information furnished in this data sheet. This information is not intended as a warranty and Micrel does not assume responsibility for its use. Micrel reserves the right to change circuitry, specifications and descriptions at any time without notice. No license, whether express, implied, arising by estoppel or otherwise, to any intellectual property rights is granted by this document. Except as provided in Micrel's terms and conditions of sale for such products, Micrel assumes no liability whatsoever, and Micrel disclaims any express or implied warranty relating to the sale and/or use of Micrel products including liability or warranties relating to fitness for a particular purpose, merchantability, or infringement of any patent, copyright or other intellectual property right.

Micrel Products are not designed or authorized for use as components in life support appliances, devices or systems where malfunction of a product can reasonably be expected to result in personal injury. Life support devices or systems are devices or systems that (a) are intended for surgical implant into the body or (b) support or sustain life, and whose failure to perform can be reasonably expected to result in a significant injury to the user. A Purchaser's use or sale of Micrel Products for use in life support appliances, devices or systems is a Purchaser's own risk and Purchaser agrees to fully indemnify Micrel for any damages resulting from such use or sale.