

ACCELERATE YOUR DESIGN

The XS1-G Development Kit (XDK) is a complete and fun hardware/software development environment that provides the fastest way to start exploring Software Defined Silicon. Based on the XMOS XS1-G4 device, the XDK provides a quick and easy way to develop a wide range of products and applications.

Thanks to an embedded software design flow, development cycles with XMOS devices are extremely short. The XDK is supported by a complete suite of design tools, and to shorten your learning curve we have provided comprehensive tutorials and application examples. A quick-start guide will have you designing your first project in just a few minutes.



EVERYTHING IN ONE BOX

The XDK contains everything you need to start developing applications based on the XS1-G family of programmable devices. The XDK hardware provides a comprehensive set of peripheral devices. This allows you to quickly develop a broad range of designs using only the included hardware. If required, custom hardware can be connected via the 0.1" pitch IDC connectors. It's simple and easy to connect to hosts, peers and networks using the on-board expansion ports. Applications are loaded and debugged through the USB host connection or run directly from an SD card.

XDK FEATURES AT A GLANCE

- XS1-G4 four-XCore 400MHz device: 1600 MIPS, 256KB RAM, 32KB OTP
- Feature-rich development platform
 - QVGA colour touch screen TFT LCD
 - High performance stereo audio ADC/DAC
 - 10/100 Ethernet interface
 - SD card slot (card included)
 - USB connectivity
 - 512KB asynchronous SRAM
 - 96 pins I/O expansion from two XCores, via 0.1" IDC headers
 - XMOS link channel connections
- Complete development tool suite
 - C and XC compilers, linker and mapper
 - Simulator and in-circuit visual debugger
- Tutorial suite with examples
 - Pong game, audio analyser, fractals, GUI demo and more
- Power supply and cables included

XDK HARDWARE BLOCK DIAGRAM

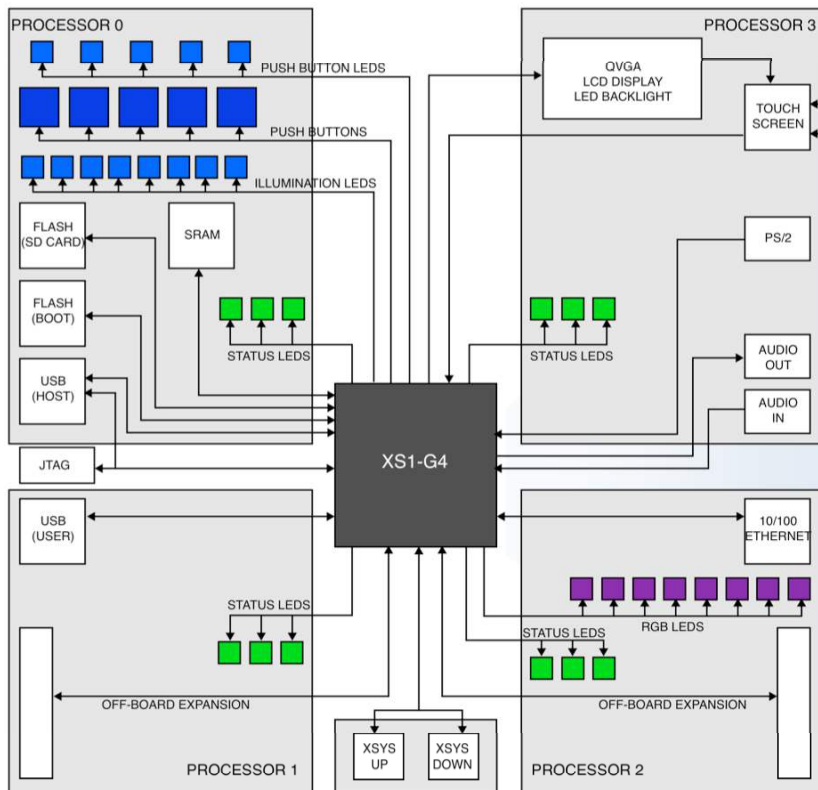

XS1-G4 Features

- Four 32-bit XCore™ event-driven processors
 - 1600MIPS performance
 - 256KBytes single-cycle SRAM
 - 32 concurrent threads
 - 400M events per second
- Up to 256 input/output pins
 - 10ns timing resolution
 - Serialisation and logic functions
- Compact 16/32bit ISA
 - 32 x 32 → 64bit MAC
- 128 communication channels
 - Scalable and deterministic on and off-chip communication

DESIGN TOOLS

The XDK is supported by an integrated development environment, a complete tool suite that includes C and XC compilers, a simulator, visualisation tools and a debugger.

Applications can be written in C, C++ and the XMOS-originated XC, an extension to C that supports concurrent and real-time programming using channel-based communications and event driven control. A step-by-step tutorial is provided that will have you proficient in XC within an hour.

For more information about our XMOS or our products, to purchase an XDK, or to explore our development tools, please visit www.xmos.com or contact your local XMOS sales representative.

