

### Features

- LIN 2.x / SAE J2602 compliant
- Operating voltage  $V_{SUP} = 5 \dots 27 \text{ V}$
- 3 modes: Normal, Silent and Sleep
- Linear low drop voltage regulator:
  - MLX80030/31:
    - Normal mode 3.3V/70mA  $\pm 2\%$
    - Silent mode 3.3V/20mA  $\pm 2\%$
  - MLX80050/51:
    - Normal mode 5V/70mA  $\pm 2\%$
    - Silent mode 5V/20mA  $\pm 2\%$
- Low current consumption (typ)
  - Sleep mode 20  $\mu\text{A}$
  - Silent mode "noload" 45  $\mu\text{A}$
- Output current limitation
- LIN-Bus Transceiver
  - Baud rate up to 20 kbaud
  - Slew rate control for best EME behaviour
  - Low slew mode for optimized SAE J2602 transmission
  - High impedance LIN pin in case of loss of ground or battery
  - Bus input voltages -24V to 30V independent from VBat
- Remote and local wake up source recognition
- VCC undervoltage detection at NRES output (start-up delay 4ms)
  - Vres threshold 3.0 V (MLX80030/31); Vres threshold 4.1V (MLX80050/51)
- Programmable Window Watchdog (only MLX80031/51)
- VSUP undervoltage detection (POR), Over temperature shutdown
- TxD dominant time out function, Standby mode time out after 350ms
- Automotive temperature range of  $-40^{\circ}\text{C}$  to  $125^{\circ}\text{C}$
- Interface I/O's independent from voltage regulator output
- Enhanced ESD robustness according to IEC 61000-4-2
  - Direct discharge for pin LIN >20kV (only Lin cap connected) and for pin VBAT >15kV
  - Indirect discharge for pin LIN >15kV
- Load dump protected (40V)

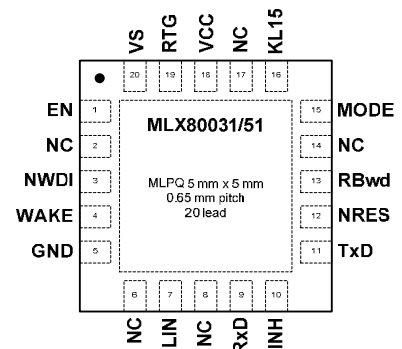
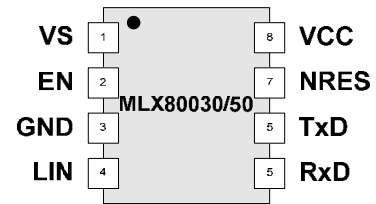

Order Code	Temp. Range	Package	Delivery	Remark
MLX80050 KDC-BAA-000-RE	-40 - 125 °C	SOIC8	Reel	
MLX80051 KLQ-BAA-000-RE	-40 - 125 °C	QFN 5x5	Reel	
MLX80030 KDC-BAA-000-RE	-40 - 125 °C	SOIC8	Reel	
MLX80031 KLQ-BAA-000-RE	-40 - 125 °C	QFN 5x5	Reel	

### Short Description

The MLX8005x/3x consist of a low-drop voltage regulator 5V/3.3V/70mA combined with a Reset/Watchdog unit and a LIN bus transceiver. The LIN transceiver is suitable for LIN bus systems conform to LIN specification revision 2.x and SAE J2602. The watchdog times of the integrated window watchdog can be adapted on application needs via external resistors. With the help of an external bipolar transistor it is possible to extend the output current of the integrated voltage regulator. The combination of voltage regulator and bus transceiver as well as watchdog unit makes it possible to develop simple, but powerful and cheap slave nodes in LIN Bus systems.

## Contents

LIST OF TABLES .....	4
LIST OF FIGURES .....	4
1. ELECTRICAL SPECIFICATION .....	5
1.1. DC CHARACTERISTICS .....	6
1.2. AC CHARACTERISTICS .....	11
1.3. TIMING DIAGRAMS .....	14
2. PIN CONFIGURATION .....	15
2.1. MLX80030 AND MLX80050 - SOIC8.....	15
2.2. MLX80031 AND MLX80051 IN QFN20 .....	16
3. FUNCTIONAL DESCRIPTION .....	17
3.1. SUPPLY PIN VS .....	19
3.2. EN INPUT PIN.....	19
3.3. GROUND PIN GND .....	19
3.4. LIN .....	19
3.5. RECEIVER OUTPUT RXD .....	19
3.6. TRANSMIT INPUT TXD .....	19
3.6.1. TxD dominant time-out feature .....	19
3.7. OUTPUT NRES.....	20
3.8. VOLTAGE REGULATOR PINS VCC AND RTG.....	20
3.9. INH OUTPUT (ONLY MLX80031/51).....	20
3.10. WAKE INPUT (ONLY MLX80031/51).....	20
3.11. KL15 INPUT (ONLY MLX80031/51) .....	20
3.12. WATCHDOG TRIGGER INPUT NWDI (ONLY MLX80031/51).....	20
3.13. WATCHDOG OSCILLATOR RESISTOR RB <sub>WD</sub> (ONLY MLX80031/51).....	20
3.14. MODE INPUT MODE (ONLY MLX80031/51).....	20
4. OPERATIONAL MODES .....	21
4.1. MODES OVERVIEW.....	22
4.2. INITIALISATION AND STANDBY MODE .....	23
4.3. NORMAL MODE .....	23
4.4. SILENT MODE .....	24
4.5. SLEEP MODE .....	25
4.6. INIT-STATE .....	27
5. WAKE UP PROCEDURES .....	28
5.1. WAKE UP SOURCE RECOGNITION IN MLX80031/51 .....	28
6. FUNCTIONALITY .....	29
6.1. RESET BEHAVIOUR OF MLX8003x/5x .....	29
6.2. THERMAL SHUTDOWN .....	29
6.3. VS UNDER VOLTAGE RESET .....	30
6.4. LIN-TRANSCEIVER .....	30
6.5. VOLTAGE REGULATOR .....	31
7. WINDOW-WATCHDOG (ONLY MLX80031/51) .....	32
7.1. MLX80031/51 WATCHDOG BEHAVIOUR .....	32
7.2. ALL WATCHDOG START-UP SCENARIOS .....	33
7.2.1. After power-on and initialization .....	33
7.2.2. Wake up indicated transition to Standby Mode from Sleep or Silent Mode .....	33

7.2.3. Undervoltage reset on VCC on Normal Mode or Silent Mode.....	33
7.2.4. EN indicated transition from Silent Mode to Normal Mode.....	33
7.3. CALCULATION OF WATCHDOG PERIOD .....	34
8. FAIL-SAFE FEATURES .....	36
9. APPLICATION HINTS.....	37
9.1. SAFE OPERATING AREA .....	37
9.2. APPLICATION CIRCUITRY .....	38
9.2.1. EMI Suppressing .....	39
9.2.2. EMC disturbances using the example of MLX80030/50 .....	39
10. MECHANICAL SPECIFICATION .....	41
10.1. SOIC8 PACKAGE .....	41
10.2. QFN20 5X5 PACKAGE.....	42
11. REVISION HISTORY .....	43
12. STANDARD INFORMATION REGARDING MANUFACTURABILITY OF MELEXIS PRODUCTS WITH DIFFERENT SOLDERING PROCESSES .....	45
13. DISCLAIMER.....	46

### List of Tables

Table 1: Absolute maximum ratings .....	5
Table 2: Voltage Regulator and Reset Unit.....	6
Table 3: LIN DC Characteristics .....	10
Table 4: AC Characteristics.....	11
Table 5: MLX80050/30 pin list in SOIC8 .....	15
Table 6: MLX80051/31 pin list in QFN20.....	16
Table 7: MLX80050/30 Operation Modes .....	22
Table 8: MLX80051/31 Operation Modes .....	22
Table 9: Parameters of Window Watchdog.....	35
Table 10: Window Watchdog Timing Selection.....	35
Table 11: Parameter ranges for function state A (MLX80050).....	40
Table 12: SOIC8 dimensions.....	41
Table 13: QFN20 Package Dimensions .....	42

### List of Figures

Figure 1: LIN propagation delays .....	14
Figure 2: LIN duty cycles .....	14
Figure 3: MLX80050/30 Block Diagram.....	17
Figure 4: MLX80051/31 Block Diagram.....	18
Figure 5: MLX8005x3x state diagram of modes of operation .....	21
Figure 6: LIN wake-up from Silent Mode .....	24
Figure 7 Local Wake-up from Silent Mode via WAKE.....	25
Figure 8: Remote wake-up from Sleep Mode.....	26
Figure 9: Local wake-up from Sleep Mode.....	27
Figure 10: VCC reset behavior .....	29
Figure 11: MLX80031/51 Watchdog behavior.....	32
Figure 12: Watchdog timing.....	33
Figure 13: Watchdog open and close window tolerances.....	34
Figure 14: Safe operating area for MLX80030/50 in SOIC-8 for Vsup up to 18V .....	37
Figure 15: Safe operating area for MLX80031/51 in QFN20 for Vsup up to 18V .....	38
Figure 16: Application circuit with MLX80050 or MLX80030 (slave node).....	38
Figure 17: Application circuit with MLX80031 or MLX80051 (slave node).....	39
Figure 18: Part of test circuitry for EMC tests with MLX80030/50.....	40
Figure 19: SOIC8 Drawing .....	41
Figure 20: QFN20 Drawing.....	42

### 1. Electrical Specification

All voltages are referenced to ground (GND), positive currents flow into the IC.

#### Absolute Maximum Ratings

**Table 1: Absolute maximum ratings**

Parameter	Symbol	Condition	Min	Max	Unit
Supply voltage at VS	VS	Respective to GND	-0.3	40	V
Transient voltage ISO 7637/2		pulse 1, 2	-100	100	V
Transient voltage ISO 7637/2		pulse 3A; 3B, coupling 1nF	-150	100	V
DC voltage LIN	V <sub>LIN_DC</sub>	Respective to GND and VS Loss of Ground (VGND = VS)	-20 -30	40 40	V
DC voltage WAKE	V <sub>WAKE_DC</sub>	Respective to GND and VS Loss of Ground (VGND = VS)	-20 -30	40 40	V
DC voltage INH	V <sub>INH_DC</sub>		-0.3	VS+0.3	V
DC voltage VCC	V <sub>VCC_DC</sub>		-0.3	7	V
DC voltage RTG	V <sub>RTG_DC</sub>		-0.3	7	V
Input voltage at low voltage I/O's (EN, TxD, RxD, NRES, WDI, RB <sub>WD</sub> )	V <sub>IN</sub>		-0.3	7	V
ESD voltage	V <sub>ESDIEC</sub>	IEC 61000-4-2, direct ESD Pin LIN with LIN cap 220pF Pin VS to GND	20 15		kV
	V <sub>ESDIECind</sub>	IEC 61000-4-2, indirect ESD Pin LIN with LIN cap 220pF	15		kV
	V <sub>ESDHBM</sub>	HBM (CDF-AEC-Q100-002) Pin LIN Pin WAKE, KL15, VS Other pins	±6 ±4 ±2		kV kV kV
	V <sub>ESDCDM</sub>	CDM (AEC-Q100-011)	±500		V
Power dissipation	P <sub>0</sub>		Internal limited see also chapter 9.1		
Thermal resistance from junction to ambient	R <sub>THJA_SOIC8</sub>	JEDEC 1s0p board, no air flow		150	K/W
	R <sub>THJA_QFN20</sub>	JEDEC 1s0p board, no air flow		50	K/W
Junction temperature	T <sub>J</sub>		-40	150	°C
Storage temperature	T <sub>STG</sub>		-55	150	°C

### 1.1. DC Characteristics

Unless otherwise specified all values in the following tables are valid for  $V_S = 5$  to 27V and  $T_{AMB} = -40$  to 125°C. All voltages are referenced to ground (GND), positive currents flow into the IC. For MLX80031/51 apply: RTG connected to VCC.

**Table 2: Voltage Regulator and Reset Unit**

	Parameter	Symbol	Condition	Min	Typ	Max	Unit	T <sup>[1]</sup>
<b>Supply Voltage Pin VS</b>								
	Nominal DC operating voltage	$V_S$		5		27	V	A
1.01	$V_S$ under voltage reset	$V_{SUVR\_OFF}$	$V_S$ ramp up	2.9		4.6	V	A
1.02	$V_S$ under voltage reset	$V_{SUVR\_ON}$	$V_S$ ramp down	2.4		4.2	V	A
1.03	$V_S$ under voltage reset hysteresis	$V_{SUVR\_HYS}$	$V_{SUVR\_OFF} - V_{SUVR\_ON}$	0.04	0.3	0.7	V	A
<b>Supply currents MLX80030, MLX80050</b>								
2.00	Supply current, normal mode	$I_{VS\_nor}$	$V_S \leq 14V, V_{EN} > 2V$ , LIN recessive, no load at VCC	400	750	1500	$\mu A$	A
2.01	Supply current, sleep mode	$I_{VS\_sleep}$	$V_S \leq 14V$ $T_A = 25^\circ C$ $-40^\circ C \leq T_A \leq 125^\circ C$		20	20 30	$\mu A$	A
2.02	Supply current, silent mode	$I_{VS\_sil}$	$V_S \leq 14V$ , LIN recessive no load at VCC $T_A = 25^\circ C$ $-40^\circ C \leq T_A \leq 125^\circ C$	20	45	65 85	$\mu A$	A
<b>Supply currents MLX80031, MLX80051</b>								
2.00	Supply current, normal mode [2]	$I_{VS\_nor}$	$V_S \leq 14V, V_{EN} > 2V, R_{BWD} = 60k$ LIN recessive, no load at VCC	400	750	1500	$\mu A$	A
2.01	Supply current, sleep mode	$I_{VS\_sleep}$	$V_S \leq 14V$ $T_A = 25^\circ C$ $-40^\circ C \leq T_A \leq 125^\circ C$		20	20 30	$\mu A$	A
2.02	Supply current, silent mode	$I_{VS\_sil}$	$V_S \leq 14V$ , LIN recessive no load at VCC $T_A = 25^\circ C$ $-40^\circ C \leq T_A \leq 125^\circ C$	20	45	65 85	$\mu A$	A

	Parameter	Symbol	Condition	Min	Typ	Max	Unit	T <sup>(1)</sup>
<b>Voltage Regulator Pin VCC</b>								
<i>MLX80050, MLX80051 (RTG connected to VCC)</i>								
3.01	Output voltage VCC	V <sub>CCn5</sub>	6V ≤ V <sub>S</sub> ≤ 18V 1mA ≤ I <sub>LOAD</sub> ≤ 70mA T <sub>A</sub> = 25°C T <sub>A</sub> = -40°C to 125°C	4.90 4.85	5.0	5.10 5.15	V	A
	Output voltage VCC under disturbances to fulfil functional state A	V <sub>CCndis5</sub>	6V ≤ V <sub>S</sub> ≤ 18V, T <sub>A</sub> = 25°C R <sub>LOAD</sub> = 330 Ω	4.75		5.25	V	C
3.02	Drop-out voltage <sup>[3]</sup>	V <sub>D10_5</sub>	V <sub>S</sub> > 4V, I <sub>VCC</sub> = 10mA		75	120	mV	A
3.03		V <sub>D30_5</sub>	V <sub>S</sub> > 4V, I <sub>VCC</sub> = 30mA		220	350	mV	A
3.04		V <sub>D70_5</sub>	V <sub>S</sub> > 4V, I <sub>VCC</sub> = 70mA		500	800	mV	A
3.05	Line regulation	V <sub>LNRS</sub>	6V ≤ V <sub>S</sub> ≤ 18V			20	mV	C
3.06	Load regulation	V <sub>LDR10_5</sub>	1 mA < I <sub>LOAD</sub> < 10 mA			50	mV	A
3.07		V <sub>LDR30_5</sub>	1 mA < I <sub>LOAD</sub> < 30 mA			90	mV	A
3.08		V <sub>LDR70_5</sub>	1 mA < I <sub>LOAD</sub> < 70 mA			150	mV	A
3.09	Output current limitation	I <sub>VCCCLIM_5</sub>	V <sub>S</sub> > 6V T <sub>A</sub> = -40 °C 25 °C ≤ T <sub>A</sub> ≤ 125 °C	-135 -150	-110	-75 -80	mA	A
3.10	Load capacity	C <sub>LOAD</sub>		2.2	22		μF	D
<i>MLX80030, MLX80031 (RTG connected to VCC)</i>								
3.01	Output voltage VCC	V <sub>CCn3</sub>	4 V ≤ V <sub>S</sub> ≤ 18 V 1mA ≤ I <sub>LOAD</sub> ≤ 70 mA T <sub>A</sub> = 25 °C T <sub>A</sub> = -40 °C to 125 °C	3.234 3.201	3.3	3.366 3.399	V	A
	Output voltage VCC under disturbances to fulfil functional state A	V <sub>CCndis3</sub>	6 V ≤ V <sub>S</sub> ≤ 18 V, T <sub>A</sub> = 25 °C R <sub>LOAD</sub> = 330 Ω	3.135		3.465	V	C
3.02	Drop-out voltage <sup>[3]</sup>	V <sub>D10_3</sub>	V <sub>S</sub> > 3 V, I <sub>VCC</sub> = 10 mA			100	mV	A
3.03		V <sub>D30_3</sub>	V <sub>S</sub> > 3 V, I <sub>VCC</sub> = 30 mA			300	mV	A
3.04		V <sub>D70_3</sub>	V <sub>S</sub> > 3 V, I <sub>VCC</sub> = 70 mA			700	mV	A
3.05	Line regulation	V <sub>LNRS</sub>	5 V ≤ V <sub>S</sub> ≤ 18 V			20	mV	A
3.06	Load regulation	V <sub>LDR10_3</sub>	1 mA < I <sub>LOAD</sub> < 10 mA			50	mV	A
3.07		V <sub>LDR30_3</sub>	1 mA < I <sub>LOAD</sub> < 30 mA			90	mV	A
3.08		V <sub>LDR70_3</sub>	1 mA < I <sub>LOAD</sub> < 70 mA			150	mV	A
3.09	Output current limitation	I <sub>VCCCLIM_3</sub>	V <sub>S</sub> > 4 V T <sub>A</sub> = -40 °C 25 °C ≤ T <sub>A</sub> ≤ 125 °C	-135 -150	-110	-75 -80	mA	A
3.10	Load capacity	C <sub>LOAD</sub>		2.2	22		μF	D

	Parameter	Symbol	Condition	Min	Typ	Max	Unit	T <sup>(1)</sup>
<b>Output Pin NRES</b>								
4.01	Output voltage low	V <sub>OL_NRES</sub>	I <sub>NRES</sub> = 2 mA			0.4	V	A
4.02	Leakage current low	I <sub>leak_RxD</sub>	V <sub>NRES</sub> = 0 V	-5		5	µA	A
4.03	Leakage current high	I <sub>leak_RxD</sub>	V <sub>NRES</sub> = V <sub>CC</sub>	-5		5	µA	A
	Output voltage high NRES under disturbances to fulfil functional state A <sup>[4]</sup>	V <sub>OH_NRES</sub>	R <sub>load</sub> = 2.7 k to V <sub>CC</sub>	V <sub>CC</sub> -1			V	C
<i>MLX80050, MLX80051</i>								
5.01	V <sub>CC</sub> reset threshold on NRES pin	V <sub>RES5V</sub>	t > t <sub>tr</sub>	3.9	4.10	4.3	V	A
5.02	V <sub>RES</sub> Hysteresis V <sub>RESHYS</sub> =  V <sub>RES(ON)</sub> - V <sub>RES(OFF)</sub>	V <sub>RESHYS5V</sub>				200	mV	C
<i>MLX80030, MLX80031</i>								
5.01	V <sub>CC</sub> reset threshold on NRES pin	V <sub>RES3V</sub>	t > t <sub>tr</sub>	2.75	2.95	3.15	V	A
5.02	V <sub>RES</sub> Hysteresis V <sub>RESHYS</sub> =  V <sub>RES(ON)</sub> - V <sub>RES(OFF)</sub>	V <sub>RESHYS3V</sub>				100	mV	C
<b>Input Pin EN</b>								
6.01	Input voltage low	V <sub>IL_EN</sub>				0.8	V	A
6.02	Input voltage high	V <sub>IH_EN</sub>		2.0			V	A
6.03	Hysteresis	V <sub>HYS_EN</sub>		50	100	700	mV	C
6.04	Pull-down resistor	R <sub>pd_EN</sub>	V <sub>EN</sub> = V <sub>CC</sub>	50	125	250	kΩ	A
<b>Input Pin WAKE (MLX80031, MLX80051)</b>								
7.01	High level input voltage	V <sub>IH_WAKE</sub>	Sleep mode	V <sub>S</sub> -1V			V	A
7.02	Low level input voltage	V <sub>IL_WAKE</sub>	Sleep mode			V <sub>S</sub> -3.3V	V	A
7.03	Pull up current WAKE	I <sub>WAKE_PU</sub>	Normal & sleep	-30	-15	-1	µA	A
7.04	Leakage current WAKE high	I <sub>WAKE_IK</sub>	V <sub>S</sub> = 18V	-5		5	µA	A
<b>Input Pin KL15 (MLX80031, MLX80051)</b>								
8.01	High level input voltage	V <sub>IH_KL15</sub>	R <sub>v</sub> = 50kΩ	4		V <sub>S</sub> +0.3V	V	A
8.02	Low level input voltage	V <sub>IL_KL15</sub>	R <sub>v</sub> = 50kΩ	-1		2	V	A
8.03	Pull down current KL15	I <sub>KL15_PD</sub>			30	65	µA	A
<b>Input Pin MODE (MLX80031, MLX80051)</b>								
23.01	Input voltage low	V <sub>IL_MODE</sub>				0.8	V	A
23.02	Input voltage high	V <sub>IH_MODE</sub>		2.0			V	A
23.03	Hysteresis	V <sub>HYS_MODE</sub>		50	100	700	mV	C
23.04	Pull-down resistor	R <sub>pd_MODE</sub>	V <sub>MODE</sub> = V <sub>CC</sub>	200		250	kΩ	A



	Parameter	Symbol	Condition	Min	Typ	Max	Unit	T <sup>(1)</sup>
<b>Input Pin NWDI (MLX80031, MLX80051)</b>								
9.01	Input voltage low	V <sub>IL_NWDI</sub>				0.8	V	A
9.02	Input voltage high	V <sub>IH_NWDI</sub>		2.0			V	A
9.03	Hysteresis	V <sub>HYS_NWDI</sub>		50	100	600	mV	C
9.04	Pull-up resistor to VCC	R <sub>pu_NWDI</sub>	V <sub>NWDI</sub> = 0V	125	250	375	kΩ	A
<b>Watchdog Oscillator pin RB<sub>WD</sub> (MLX80031, MLX80051)</b>								
10.01	Voltage at RB <sub>WD</sub>	V <sub>RBwd</sub>	I <sub>OUT</sub> = -50 μA		1.2		V	A
10.02	Range of RB <sub>WD</sub> resistance	RB <sub>WD</sub>		20		150	kΩ	B
10.03	RB <sub>WD</sub> short resistance to disable Watchdog	RB <sub>WDSH</sub>	Watchdog disabled	0		330	Ω	B
<b>Output INH (MLX80031, MLX80051)</b>								
11.01	ON Resistance	R <sub>ON_INH</sub>	V <sub>S</sub> = 12V		20	50	Ω	A
11.02	Leakage current INH high	I <sub>leakH_INH</sub>	Sleep Mode, V <sub>INH</sub> = 18V, V <sub>S</sub> = 18V	-5		5	μA	A
11.03	Leakage current INH low	I <sub>leakL_INH</sub>	Sleep Mode, V <sub>INH</sub> = 0V, V <sub>S</sub> = 18V	-5		5	μA	A
<b>Thermal Protection</b>								
	Thermal shutdown	T <sub>JSHD</sub>		155	170	190	°C	D
	Thermal hysteresis	T <sub>JHYS</sub>			10	30	°C	D

**Table 3: LIN DC Characteristics**

Parameter	Symbol	Condition	Min	Typ	Max	Unit	T <sup>[1]</sup>	
<b>General</b>								
12.01	Pull up current LIN (recessive)	$I_{INLINpu}$	$V_{LIN} = 18V, V_S = 6V$			80	$\mu A$	A
12.02	Pull up resistor LIN	$R_{LINpu}$	$V_S = 12V, V_{LIN} = 0V$	20	30	60	$k\Omega$	A
12.03	Reverse current LIN (dominant)	$I_{INLINdom}$	$V_S = 12V, V_{LIN} = 0V$	-400			$\mu A$	A
12.04	Reverse current LIN (recessive)	$I_{INLINrec}$	$V_{LIN} \geq V_S, 8V \leq V_{LIN} \leq 18V, 8V \leq V_S \leq 18V$	0		23	$\mu A$	A
12.05	Reverse current LIN (loss of battery)	$I_{INLIN_{job}}$	$V_S = 0V, 0V \leq V_{LIN} \leq 18V$	0		23	$\mu A$	A
12.06	Reverse current LIN (loss of ground)	$I_{INLIN_{log}}$	$V_S = 12V, 0V \leq V_{LIN} \leq 18V$	-10		50	$\mu A$	A
	Voltage drop serial Diode	$V_{SerDiode}$		0.4	0.7	1.0	V	D
	Battery Shift	$V_{Shift\_BAT}$		0		11.5	%	D
	Ground Shift	$V_{Shift\_GND}$		0		11.5	%	D
	Ground-Battery shift difference	$V_{Shift\_diff}$		0		8	%	D
<b>Receiver</b>								
12.07	Receiver dominant voltage	$V_{BUSdom}$	$7.0V \leq V_S \leq 18V$			$0.4*V_S$	V	A
	Receiver recessive voltage	$V_{BUSrec}$		$0.6*V_S$				A
12.08	Centre point of receiver threshold $V_{thr\_cnt} = (V_{thr\_rec} + V_{thr\_dom})/2$	$V_{thr\_cnt}$		$0.475*V_S$	$0.5*V_S$	$0.525*V_S$		A
12.09	Receiver Hysteresis $V_{hys} = V_{thr\_rec} - V_{thr\_dom}$	$V_{hys}$			$0.15*V_S$	$0.175*V_S$		A
<b>Transmitter</b>								
12.10	Transmitter dominant voltage	$V_{olbus}$	$R_{load} = 500\Omega, V_S = 5V$	0		1.2	V	D
			$R_{load} = 500\Omega, V_S \geq 7V$	0		$0.2*V_S$		A
12.11	Current limitation LIN	$I_{LIM}$	$V_{LIN} = V_S, TxD = 0V$	40	120	200	mA	A
12.12	Transmitter recessive voltage	$V_{ohBUS}$	No load, $V_{EN} = 0/5V, V_{TxD} = 5V$	$0,8*V_S$		$V_S$	V	A

Parameter	Symbol	Condition	Min	Typ	Max	Unit	T <sup>[1]</sup>
<b>Input/Output Pin TxD</b>							
13.01	Input voltage low TxD	$V_{IL\_TxD}$	rising			0.8	V A
13.02	Input voltage high TxD	$V_{IH\_TxD}$		2			V A
13.03	Hysteresis	$V_{HYS\_TxD}$		50		700	mV C
13.04	Pull-up resistor to VCC	$R_{pu\_TxD}$	$V_{TxD} = 0V$	125	250	375	k $\Omega$ A
13.06	Low level output current	$I_{OL\_TxD}$	local wake-up request; standby mode; $V_{TxD} = 0.4V$	1.5			mA A
<b>Output Pin RxD</b>							
14.01	Output voltage low RxD	$V_{OL\_RxD}$	$I_{RxD} = 2\text{ mA}$			0.6	V A
14.02	Pull-up resistor to VCC	$R_{pu\_RxD}$	$V_{RxD} = 0V$	3	5	7	k $\Omega$ A
14.03	Leakage current high	$I_{leak\_RxD}$	$V_{RxD} = V_{CC}$	-5		5	$\mu A$ A
	Output voltage high RxD under disturbances to fulfil functional state A <sup>[4]</sup>	$V_{OH\_RxD}$	$R_{load} = 2.7k\text{ to }V_{CC}$	$V_{CC}-1$			V C

**Notes:**

- [1] A = 100% serial test, B = Operating parameter, C = only used for data characterization (cpk), D = Value guaranteed by design
- [2] No watchdog reset; Watchdog trigger time on WDI = t.b.d.ms; Measurement of the average current of 10 watchdog periods.
- [3] The nominal  $V_{CC}$  voltage is measured at  $V_{SUP} = 12V$ . If the  $V_{CC}$  voltage is 100mV below its nominal value then the voltage drop is  $V_D = V_{SUP} - V_{CC}$
- [4] Functionality range of current limitation at silent mode is limited by reset threshold  $V_{RES}$ . Below them the IC change to normal mode.  
Validity for  $I_{VCC\_MAXsil}$  :  $V_{CCn}(\text{min}) \leq V_{CC} \leq V_{RES}$

## 1.2. AC Characteristics

$6V \leq V_S \leq 27V$ ,  $-40^\circ C \leq T_A \leq 125^\circ C$ , RTG connected to VCC, unless otherwise specified

**Table 4: AC Characteristics**

Parameter	Symbol	Condition	Min	Typ	Max	Unit	T <sup>[1]</sup>
<b>Reset parameter on NRES</b>							
16.01	Reset time	$t_{Res}$	$V_S = 14V$	2.5	4	5.5	ms A
16.02	Reset rising time	$t_{rr}$	$V_S = 14V$	3.0	6.5	12	$\mu s$ A
<b>Watchdog parameter on NRES (MLX80031, MLX80051)</b>							
17.01	Watchdog-Oscillator Period (on TM9)	$t_{WDOSC20}$	$RB_{WD} = 20k\Omega \pm 1\%$	6.87	8.09	9.30	$\mu s$ A
17.02		$t_{WDOSC60}$	$RB_{WD} = 51k\Omega \pm 1\%$	16.06	18.90	21.73	$\mu s$ A
17.03		$t_{WDOSC100}$	$RB_{WD} = 100k\Omega \pm 1\%$	30.58	35.98	41.37	$\mu s$ A

Parameter	Symbol	Condition	Min	Typ	Max	Unit	T <sup>[1]</sup>	
17.04		$t_{WDOSC150}$	$RB_{WD} = 150k\Omega \pm 1\%$	45.40	53.41	61.42	$\mu s$	A
	Watchdog Close Window	$t_{CW}$	$t_{WDOSC}$		1053		cycles	D
	Watchdog Open Window	$t_{OW}$	$t_{WDOSC}$		1105		cycles	D
17.05	Watchdog Reset Low Time	$t_{WDres}$		3	4	5	ms	A
	Watchdog Lead Window	$t_{LDT}$	$t_{WDOSC}$		7895		cycles	D
17.06	Watchdog Safety Oscillator	$t_{WDSafety}$	$RB_{WD} \text{ gnd}$	30	50	75	$\mu s$	A
<b>Wake-up and Mode Control</b>								
18.01	Remote Wake-up filter time	$t_{wu\_remote}$		30	70	150	$\mu s$	A
18.02	Wake-up filter time on WAKE (only MLX80051,MLX80031)	$t_{wu\_WAKE}$	Sleep or Silent Mode, WAKE falling edge	10		50	$\mu s$	A
18.03	Wake-up filter time on KL15 (only MLX80051,MLX80031)	$t_{wu\_KL15}$	Sleep or Silent Mode, KL15 rising edge	80	168	250	$\mu s$	A
18.04	Propagation delay from Normal Mode to Sleep Mode via EN	$t_{pd\_sleep}$	$V_{EN} = 0V$	5	15	20	$\mu s$	A
18.05	Propagation delay from Standby Mode to Normal Mode via EN	$t_{pd\_norm}$	$V_{EN} = 5V$	5	15	20	$\mu s$	A
18.06	Propagation delay from Silent Mode to Normal Mode via EN	$t_{pd\_sil\_n}$	$V_{EN} = 5V$	5	15	40	$\mu s$	A
18.07	Propagation delay: go to silent mode after EN=H/L <sup>[3]</sup>	$t_{pd\_sil}$	check falling edge on RBwd $EN = 0V$			20	$\mu s$	A
	Setup time TxD to EN for low slew mode	$t_{set\_TxD\_EN}$		5			$\mu s$	B
	Hold time TxD after EN for low slew mode	$t_{hold\_TxD\_EN}$		20			$\mu s$	B
18.08	Debouncing time EN	$t_{deb\_EN}$		2	5	20	$\mu s$	A
18.09	TxD dominant time out	$t_{TxD\_to}$	Normal Mode, $V_{TxD} = 0V$	27		60	ms	A
18.10	Standby time out	$t_{sby\_to}$	Standby Mode, $V_{EN} = 0V$	150		500	ms	A
<b>General LIN Parameter</b>								
19.01	Receiver propagation delay LIN -> RxD	$t_{dr\_RxD}$ $t_{df\_RxD}$	$C_{L(RxD)} = 50 \text{ pF}$			6	$\mu s$	A
19.02	Symmetry prop. delay LIN->RxD	$t_{dsym\_RxD}$	$t_{dr\_RxD} - t_{df\_RxD}$	-2		2	$\mu s$	A
19.03	Receiver debouncing time	$t_{deb\_LIN}$		1.5	2.8	4.0	$\mu s$	D

Parameter	Symbol	Condition	Min	Typ	Max	Unit	T <sup>[1]</sup>	
19.04	slew rate rising edge LIN	dV/dTrise	Normal Mode LIN-Load: 1k / 1nF	1.0	1.5	2.5	V/ $\mu$ s	C
19.05	slew rate falling edge LIN	dV/dTfall		-2.5	-1.5	-1.0	V/ $\mu$ s	C
19.06	slew rate rising edge LIN	dV/dTrise	Low Slew Mode LIN-Load: 1k / 1nF	0.3	0.8	1.3	V/ $\mu$ s	C
19.07	slew rate falling edge LIN	dV/dTfall		-1.3	-0.8	-0.3	V/ $\mu$ s	C
	Internal capacity	C <sub>LIN</sub>	Pulse at LIN via 10kOhm with 0/10 V; VS = open		25	35	pF	D
LIN transceiver parameter according to LIN Physical Layer Spec. rev. 2.0, table 3.4 (20kbit/s)								
Conditions: Normal slew mode; V <sub>S</sub> = 7.0V to 18V; LIN loads: 1k $\Omega$ /1nF; 660 $\Omega$ /6.8nF; 500 $\Omega$ /10nF TxD signal: t <sub>Bit</sub> = 50 $\mu$ s, t <sub>wH</sub> = T <sub>wL</sub> = t <sub>Bit</sub> ; t <sub>rise</sub> = t <sub>fall</sub> < 100ns								
	Minimal recessive bit time [2]	t <sub>rec(min)</sub>		40	50	58	$\mu$ s	
	Maximum recessive bit time [2]	t <sub>rec(max)</sub>		40	50	58	$\mu$ s	
20.01	Duty cycle 1	D <sub>1</sub>	D <sub>1</sub> = t <sub>rec(min)</sub> / (2*t <sub>Bit</sub> )	0.396				A
20.02	Duty cycle 2	D <sub>2</sub>	D <sub>2</sub> = t <sub>rec(max)</sub> / (2*t <sub>Bit</sub> )			0.581		A
Transceiver parameter according to LIN Physical Layer Spec. rev. 2.0, table 3.4 (10.4kbit/s)								
Conditions: Low slew mode; V <sub>S</sub> = 7.0V to 18V; LIN loads: 1k $\Omega$ /1nF; 660 $\Omega$ /6.8nF; 500 $\Omega$ /10nF TxD signal: t <sub>Bit</sub> = 96 $\mu$ s, t <sub>wH</sub> = T <sub>wL</sub> = t <sub>Bit</sub> ; t <sub>rise</sub> = t <sub>fall</sub> < 100ns								
	Minimal recessive bit time [2]	t <sub>rec(min)</sub>		80	96	113	$\mu$ s	
	Maximum recessive bit time [2]	t <sub>rec(max)</sub>		80	96	113	$\mu$ s	
21.01	Duty cycle 1	D <sub>3</sub>	D <sub>3</sub> = t <sub>rec(min)</sub> / (2*t <sub>Bit</sub> )	0.417				A
21.02	Duty cycle 2	D <sub>4</sub>	D <sub>4</sub> = t <sub>rec(max)</sub> / (2*t <sub>Bit</sub> )			0.590		A
LIN transceiver parameter according to SAE J2602 (10.4kbit/s)								
Conditions: Low slew mode; V <sub>S</sub> = 7.0V to 18V; LIN loads: 1k $\Omega$ /1nF; 660 $\Omega$ /6.8nF; 500 $\Omega$ /10nF TxD signal: t <sub>Bit</sub> = 96 $\mu$ s, t <sub>wH</sub> = T <sub>wL</sub> = t <sub>Bit</sub> ; t <sub>rise</sub> = t <sub>fall</sub> < 100ns								
22.01	Minimal recessive delay TxD -> LIN [2]	t <sub>x_rec_min</sub>				48	$\mu$ s	A
22.02	Maximum recessive delay TxD -> LIN [2]	t <sub>x_rec_max</sub>				48	$\mu$ s	A
22.03	Minimal dominant delay TxD -> LIN [2]	t <sub>x_dom_min</sub>				48	$\mu$ s	A
22.04	Maximum dominant delay TxD -> LIN [2]	t <sub>x_dom_max</sub>				48	$\mu$ s	A
22.05	Maximum rec. to dom. delay	T <sub>r_d_max</sub>	t <sub>x_rec_max</sub> - t <sub>x_dom_min</sub>			15.9	$\mu$ s	A
22.06	Maximum dom. to rec. delay	T <sub>d_r_max</sub>	t <sub>x_dom_max</sub> - t <sub>x_rec_min</sub>			17.2	$\mu$ s	A

[1] A = 100% serial test, B = Operating parameter, C = only used for data characterization (cpk),  
D = Value guaranteed by design

1.3. **Timing diagrams**

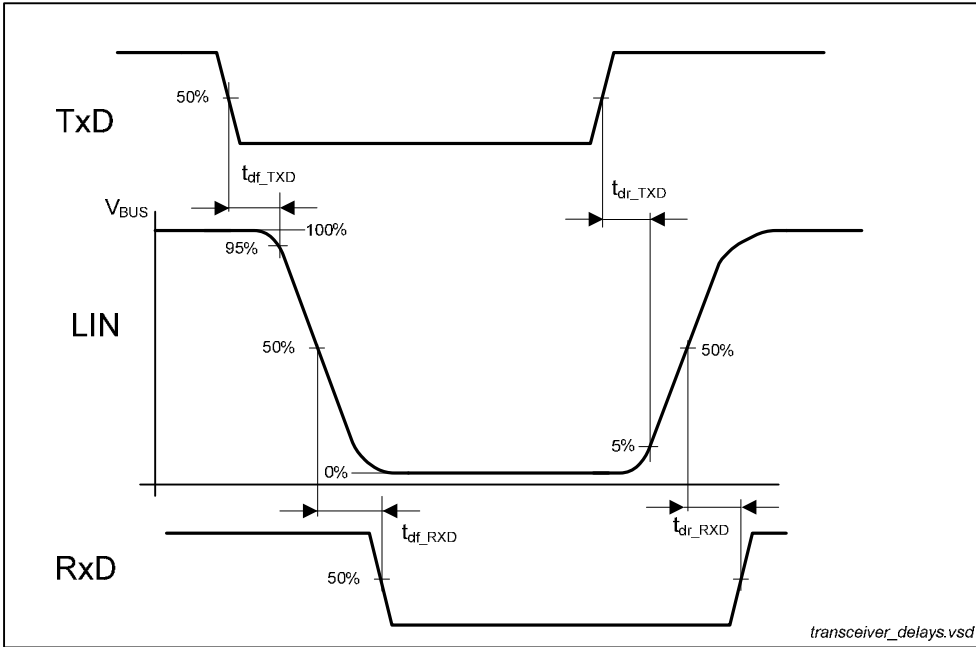

**Figure 1: LIN propagation delays**

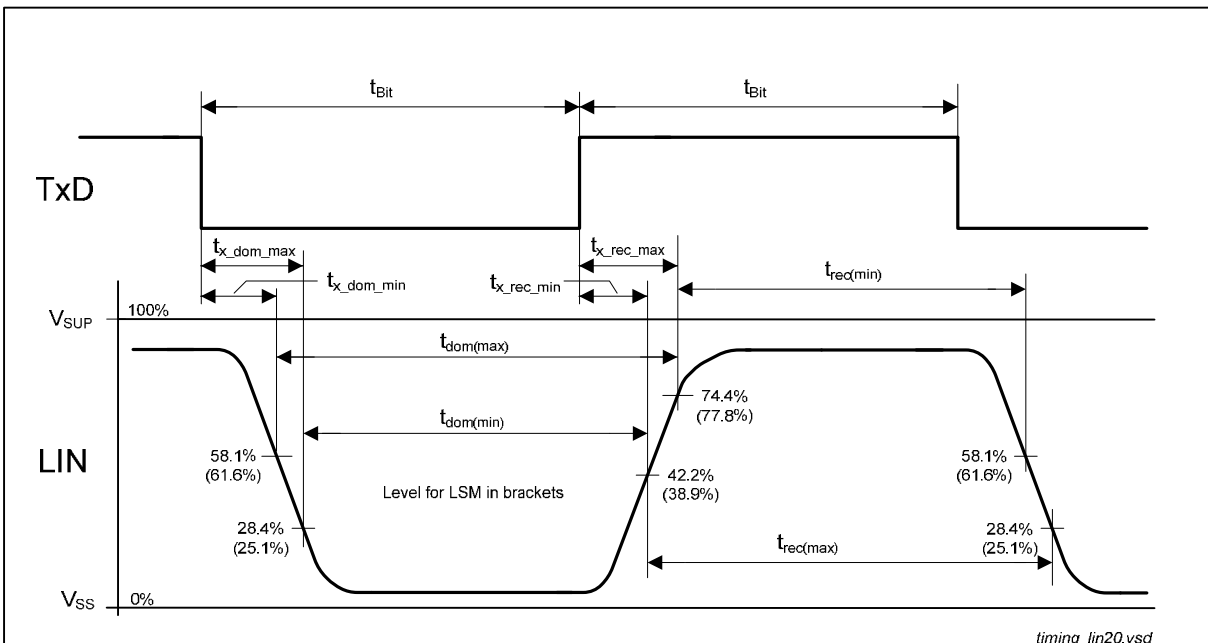

**Figure 2: LIN duty cycles**

## 2. Pin Configuration

### 2.1. MLX80030 and MLX80050 - SOIC8

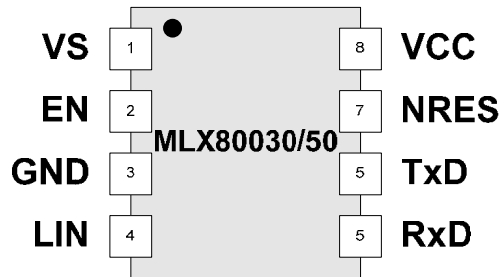

**Table 5: MLX80050/30 pin list in SOIC8**

Pin	Name	IO-Typ	Description
1	VS	P	Battery supply voltage
2	EN	I	Mode control pin, enables the normal operation mode when HIGH
3	GND	G	Ground
4	LIN	I/O	LIN bus transmitter/receiver pin, (low = dominant)
5	RxD	I/O	Received data from LIN bus, low in dominant state; internal pull-up resistor
6	TxD	I/O	Transmit data input (low = dominant)
7	NRES	O	Undervoltage reset output (open drain), low active
8	VCC	P	Voltage regulator output

### 2.2. MLX80031 and MLX80051 in QFN20

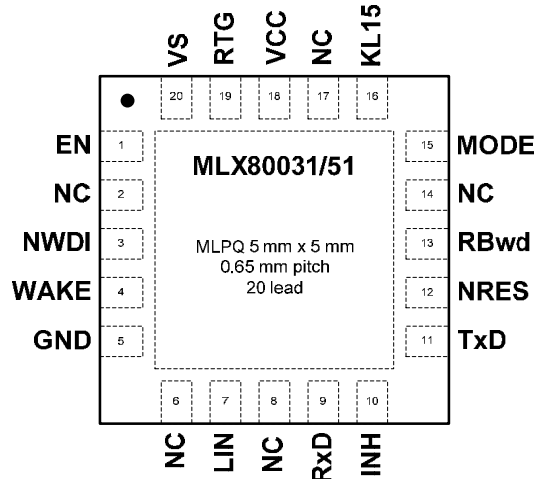

Table 6: MLX80051/31 pin list in QFN20

Pin	Name	IO-Typ	Description
1	EN	I	Mode control pin, enables the normal operation mode when HIGH
2	NC		not connected
3	NWDI	I	Watchdog trigger input; negative edge; pull-up
4	WAKE	I	High voltage input for local wake up, negative edge triggered
5	GND	G	Ground
6	NC		not connected
7	LIN	I/O	LIN bus transmitter/receiver pin, (low = dominant)
8	NC		not connected
9	RxD	I/O	Received data from LIN bus, low in dominant state; internal pull-up resistor
10	INH	O	High side switch; High voltage
11	TxD	I/O	Transmit data input (low = dominant)
12	NRES	O	Reset output (open drain), low active
13	RBwd	I/O	Bias resistor for watchdog oscillator
14	NC		not connected
15	MODE	I	Input to control window watchdog; internal pull-down resistor
16	KL15	I	High voltage input for local wake up, positive edge triggered
17	NC		not connected
18	VCC	I	Voltage regulator sense input
19	RTG	P	Voltage regulator output
20	VS	P	Battery supply voltage



### 3. Functional Description

The MLX8003x/5x consists of a low drop 3.3V/5V voltage regulator capable to drive 70mA and a LIN bus transceiver, which is a bi-directional bus interface for data transfer between LIN bus and the LIN protocol controller. Additionally integrated is a Window-Watchdog/RESET unit with a fixed power-on-reset delay of 4 ms and an adjustable watchdog time defined by an external bias resistor.

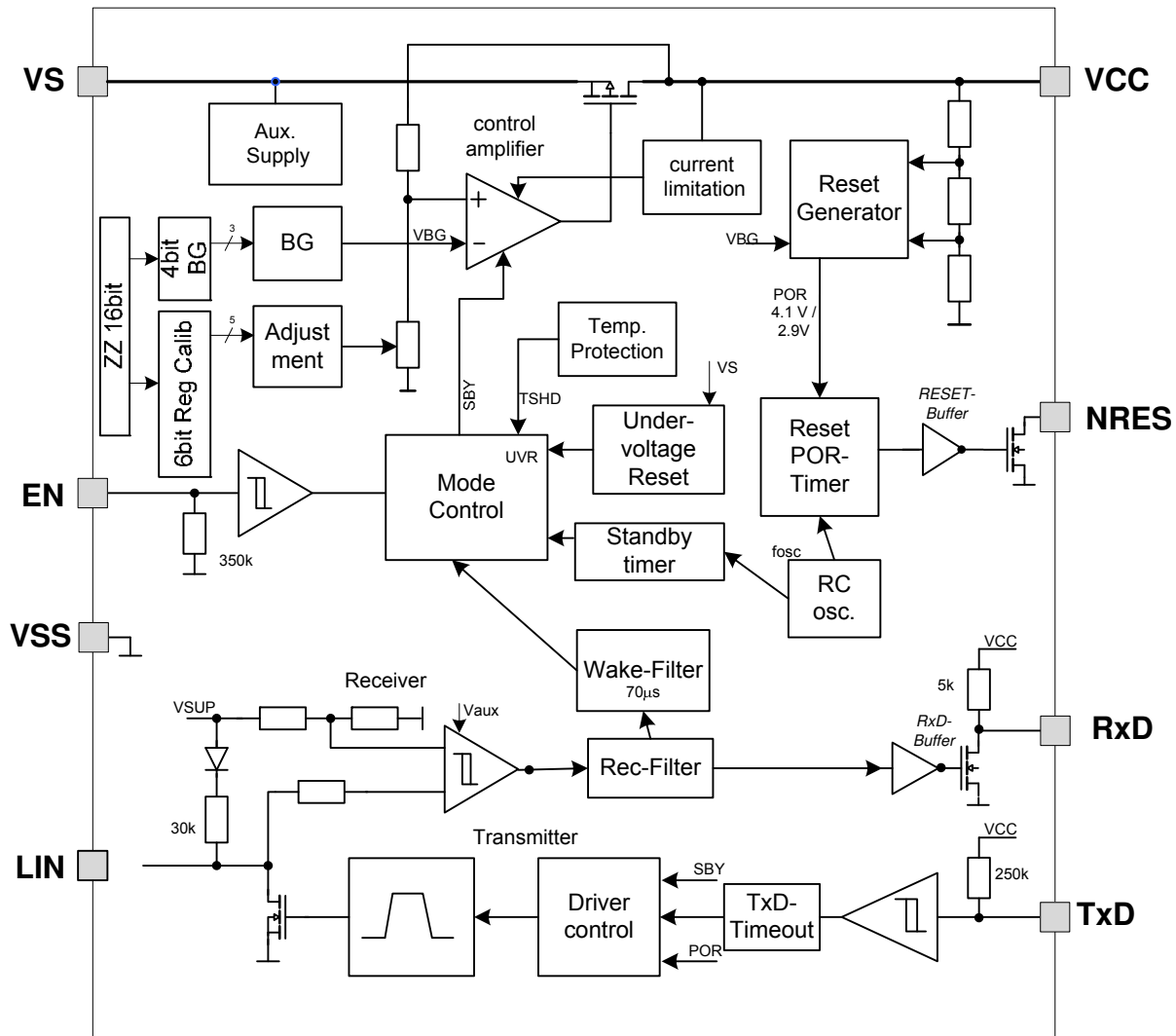

Figure 3: MLX80050/30 Block Diagram



### 3.1. **Supply Pin VS**

VS is the operational voltage pin of MLX8005x/3x. The voltage range is  $V_S = 6$  to 18V. After switching on VS, the MLX8003x/5x starts at Standby Mode and the VCC voltage regulator ramps up. An undervoltage detection unit prevents an undefined operation for  $V_S < 4V$ .

#### **VS- Power-ON**

If VS is switched on, the MLX8003x/5x starts in Standby Mode. A combination of dynamic POR and under voltage reset circuitry generates a POR signal, which switches the MLX8003x/5x on. This power on behaviour is independent from the status of the EN-pin.

Power-on reset and under-voltage reset operate independent from each other, which secures the independence from the rise time of VS.

### 3.2. **EN input pin**

The ENable input is the mode control pin of MLX8003x/5x in combination with the TxD input.

The MLX8003x/5x is switched into the Sleep Mode with a falling edge and into normal mode with a rising edge at the EN pin. The state machine goes to Normal Mode after  $t_{Res}$  (see also Table 4: AC Characteristics). The Normal Mode will be kept as long as EN remains high.

The Normal Mode can be entered from Standby Mode, when the pin EN is driven HIGH. To prevent unwanted mode transitions, the EN input contains a debounce filter as specified ( $t_{EN\_deb}$ ).

The pin EN contains a weak pull down resistor. The input thresholds are compatible to 3.3V and 5V supply systems.

#### MLX80031/51:

Additionally the positive edge on pin EN results in an immediate reset of the active low interrupt on pin RxD as well as the wake-up source recognition flag on pin TxD.

### 3.3. **Ground pin GND**

This is the reference pin of the IC. The absence of GND connection will not influence or disturb the communication between other LIN bus nodes.

### 3.4. **LIN**

This bidirectional pin consists of a low side driver in the output path and a high-voltage comparator in the input path. Furthermore is integrated a LIN pull-up resistor between LIN and VS pin. Low side driver consists of a current limitation.

### 3.5. **Receiver Output RxD**

The pin RxD is a buffered open drain output. Output signals can be shifted by the external pull up resistor to 3.3V and 5V supply systems.

### 3.6. **Transmit Input TxD**

The transmit data stream of the LIN protocol controller applied to the pin TxD is converted into the LIN bus signal with slew rate control in order to minimize electromagnetic emissions.

The pin TxD contains a weak pull up resistor. The input thresholds are compatible to 3.3V and 5V supply systems. To enable the transmit path, the TxD pin has to be driven recessive (HIGH) after or during the normal mode has been entered.

#### **3.6.1. TxD dominant time-out feature**

With the first dominant level on pin TxD after the transmit path has been enabled, the dominant time-out counter is started. In case of a faulty blocked permanent dominant level on pin TxD the transmit path will be disabled after the specified time  $t_{TxD\_to}$ . The time-out counter is reset by the first negative edge on pin TxD.

### 3.7. **Output NRES**

The NRES pin outputs the reset state as well as the watchdog condition in MLX80031 and MLX80051.

### 3.8. **Voltage regulator pins VCC and RTG**

The MLX80030/50 has an integrated low drop linear regulator with a p-channel-MOSFET as driving transistor. This regulator outputs a voltage of 5V  $\pm$ 2% (MLX80050/51) or 3.3V  $\pm$ 2% (MLX80030/31) with a load current of max. 70mA. The current limitation unit limits the output current for short circuits or overload to 130mA by decreasing the VCC voltage. This way the power dissipation is held constant at a maximum value.

The voltage regulator has two pins, output pin RTG and sense input pin VCC. For MLX80030/50 both, RTG and VCC, are commonly bonded to pin VCC on the package.

Devices MLX80031/51 has both pins bonded and provides the possibility to use an external npn transistor to boost the maximum load current. In this case the basis of the npn transistor has to be connected to the RTG pin and the emitter to the VCC pin. In case of using the internal voltage regulator, both pins have to be connected to each other.

### 3.9. **INH Output (only MLX80031/51)**

INH switches to high (VS connected to INH) in case of Standby or Normal Mode. INH is switched off at Silent and Sleep Mode. The pin will be used for switch on an external power supply or for switch off the external 1k master resistor in master node applications.

### 3.10. **WAKE Input (only MLX80031/51)**

High voltage input pin for local wake-up functionality. With a falling edge on WAKE the IC wakes-up from Silent Mode or Sleep Mode to Standby Mode.

The pin WAKE provides a weak pull up current source towards Vs which provides a HIGH level on the pin in case of open circuit failures or if no local wake-up feature is required. In such applications it is recommended to connect the pin WAKE directly to pin Vs in order to prevent influences due to EMI.

### 3.11. **KL15 Input (only MLX80031/51)**

High voltage input pin for local wake-up functionality. With a rising edge on KL15 the IC wakes-up from Silent Mode or Sleep Mode to Standby Mode.

The pin KL15 provides a weak current sink towards GND which provides a LOW level on the pin in case of open circuit failures or if no local wake-up feature is required. In such applications it is recommended to connect the pin KL15 directly to GND in order to prevent influences due to EMI. KL15 is typically connected to the ignition terminal and generates a local wake-up at start of ignition.

### 3.12. **Watchdog Trigger Input NWDI (only MLX80031/51)**

This input is used to trigger the integrated window watchdog in MLX80031/51. Every falling edge on NWDI in watchdog open window is used to reset the watchdog timer. An internal pull up resistor of 250k secures a stable high condition if this pin is open. The NWDI input is a low voltage CMOS input.

### 3.13. **Watchdog Oscillator Resistor RB<sub>WD</sub> (only MLX80031/51)**

A resistor between RB<sub>WD</sub> and GND defines the window watchdog times as trigger time and reset time.

### 3.14. **Mode Input MODE (only MLX80031/51)**

Special pin for to disable the window watchdog function. For normal watchdog operation connect the MODE pin to GND directly or via external resistor. With MODE pin on 3.3V/5V the window watchdog is switched off.

### 4. Operational Modes

The MLX8003x/5x provides four main operating modes “Standby”, “Normal”, “Silent” and “Sleep”. The main modes are fixed states defined by basic actions (VS start, EN or wake-up).

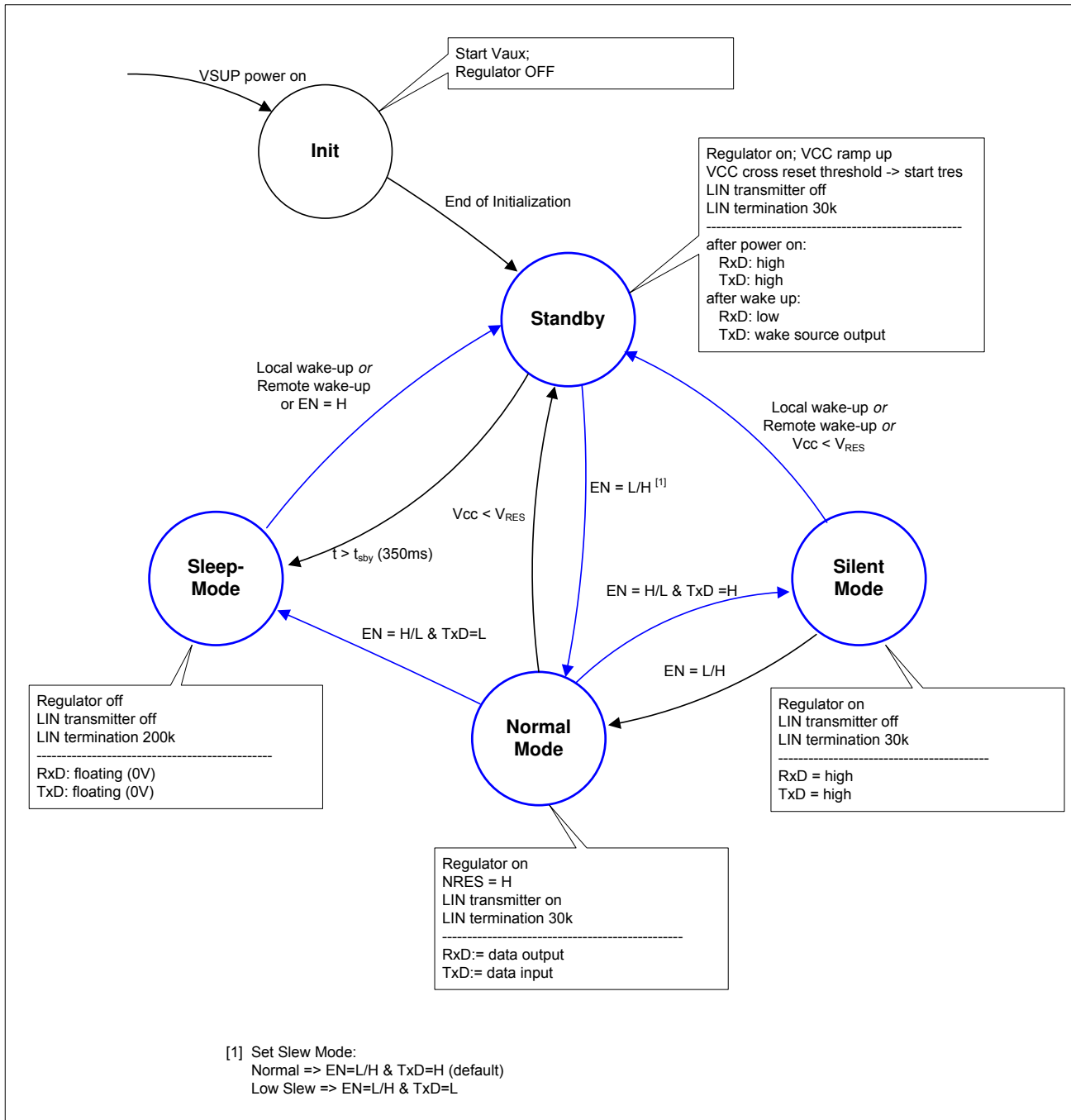

**Figure 5: MLX8005x3x state diagram of modes of operation**

### 4.1. Modes Overview

**Table 7: MLX80050/30 Operation Modes**

Mode	VCC	TxD	RxD	LIN	remarks
Standby	3.3V/5V	high	high	recessive	entered after power on or wake up
Normal	3.3V/5V	input for transmit data stream	output for LIN data stream	follows TxD	[1]
Silent	3.3V/5V	high	high	recessive	high = 3.3V/5V
Sleep	0	floating	floating	recessive	remote wake up to enter Standby Mode, EN = H to go to Normal Mode

[1] Normal mode will be entered from Standby Mode by a low -> high transition on pin EN and from Sleep Mode by EN = H after startup of the regulator. When recessive level (high) on pin TxD is present the transmit path will be enabled

**Table 8: MLX80051/31 Operation Modes**

Mode	VCC	TxD	RxD	LIN	INH	Watchdog	remarks
Standby	3.3V/5V	High/ active low <sup>[1]</sup>	high/ active low <sup>[2]</sup>	recessive	ON	ON	entered after power on or wake up
Normal	3.3V/5V	input for transmit data stream	output for LIN data stream	follows TxD	ON	ON	[3] [4] [5]
Silent	3.3V/5V	high	high	recessive	OFF	OFF	
Sleep	0	floating	floating	recessive	OFF	OFF	Local or remote wake up to enter Standby Mode, EN = H to go to Normal Mode

[1] Indicates the wake up flag in case of local wake up  
 [2] After power on RxD is going high via pull-up to Vcc. If any wake up(local or remote) occurs it will be indicated by active low  
 [3] Active low interrupt at pin RxD will be removed when entering normal mode  
 [4] Wake up source flag at pin TxD will be removed when entering normal mode  
 [5] Normal mode will be entered from Standby Mode by a low -> high transition on pin EN and from Sleep Mode by EN = H after startup of the regulator. When recessive level (high) on pin TxD is present the transmit path will be enabled

### 4.2. *Initialisation and Standby mode*

When the battery supply voltage  $V_S$  exceeds the specified threshold  $V_{SUVR\_OFF}$ , the MLX8003x/5x automatically enters the Standby Mode. Following internal procedure is running:

**First:**

- Start of internal supply  $V_{aux}$  and POR of  $V_{aux}$
- Start of internal RC oscillator

**Second** and parallel after POR:

- Start of voltage regulator

The output voltage  $V_{CC}$  ramps up to nominal value. The pin RxD is floating and the integrated slave pull up resistor with decoupling diode pulls the pin LIN. The transmitter as well as the receiver is disabled.

If there occurs no mode change to Normal Mode via an EN LOW to HIGH transition within the time stated (typically 350ms), the IC enters the most power saving Sleep Mode.

Furthermore the standby mode will be entered after a valid local or remote wake up event, when the MLX8003x/5x is in Sleep or Silent mode. The entering of the standby mode after wake up will be indicated by an active LOW interrupt on pin RxD.

### 4.3. *Normal Mode*

This mode is the base mode. The bus transceiver is able to send with a max baud rate of 20kbit/s.

The whole MLX8003x/5x is active. The incoming bus traffic is detected by the receiver and transferred via the RxD output pin to the microcontroller.

To exit the Normal Mode with on of the following condition:

1. High-to-low edge on EN pin with TxD = H -> switch to Silent Mode
2. High-to-low edge on EN pin with TxD = L -> switch to Sleep Mode
3. Undervoltage monitor on VCC detects a low voltage reset condition ( $V_{CC} < V_{RES}$ ) -> switch back to stand-by mode.

#### *Low Slew Mode*

The first rising edge on EN after power-on defines the slew rate of the device. With TxD = High at this point works the MLX8003x/5x with normal slew rate (default state). TxD = Low activates the Low Slew Mode, as long as  $V_S > V_{SUVR\_OFF}$ .

In this mode the slew rate is switched from the normal value of typ. 1.6V/ $\mu$ s to a low value of typ. 0.8V/ $\mu$ s. This mode is optimized to send with a maximum baud rate of 10.4kbit/s (acc. to SAE J2602). Because of this reduction of the slew rate the EME behaviour is improved especially in the frequency range of 100 kHz to 10MHz.

### 4.4. Silent Mode

The Silent Mode is a special mode for application with active Sleep Mode on LIN, but the connected MCU still needs to be supplied with VCC.

With a falling edge on EN input in combination with TxD=high switches the MLX8003x/5x from Normal Mode to the Silent Mode with reduced internal current consumption.

In Silent Mode the voltage regulator is on with a 2% tolerance. The transmitter is disabled and the pin RxD is disconnected from the receive path and is floating. The slave termination resistor (LIN pull up resistor with decoupling diode between pins LIN and VS) is disconnected; only a weak current source is applied to the LIN bus. Value is typical -75uA, limits -20...-100uA.

To exit the silent mode with on of the following condition:

1. Low-to-high edge on the EN pin -> switch back to normal mode
2. Remote wake up (all versions) or local wake up request (MLX80031/51 only) -> switch to standby mode
3. Undervoltage monitor on VCC detects a low voltage reset condition ( $V_{CC} < V_{RES}$ ) -> switch back to stand-by mode.

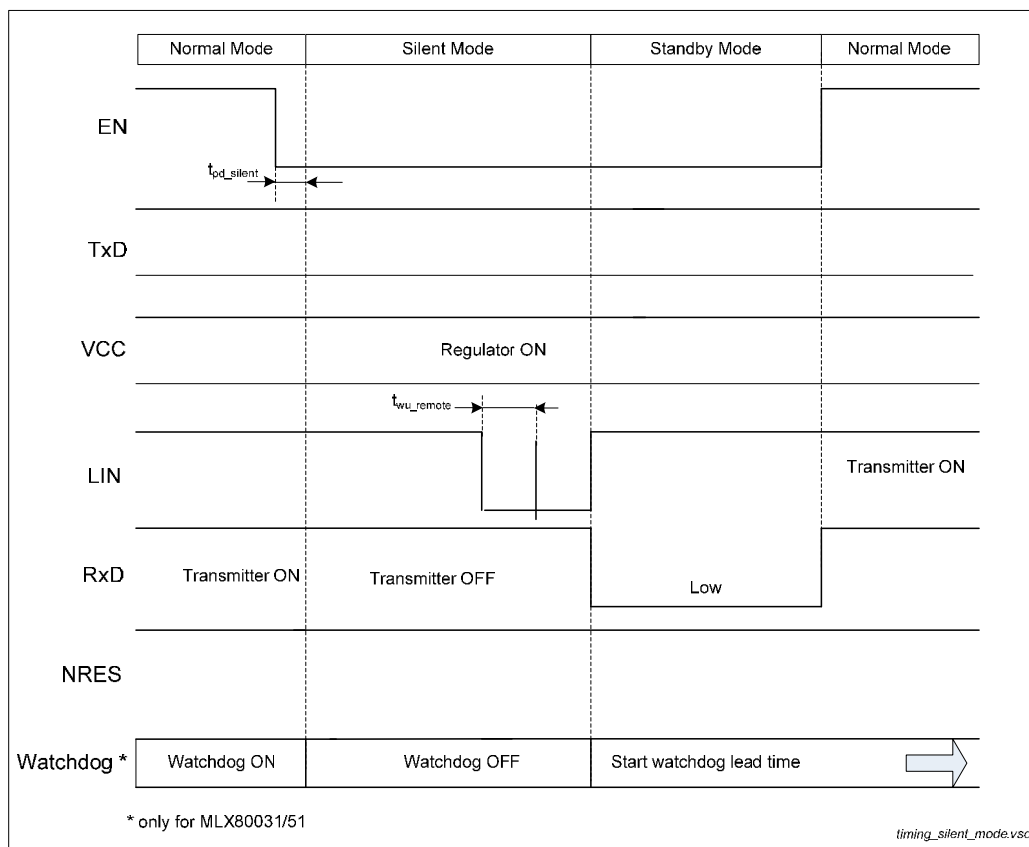

**Figure 6: LIN wake-up from Silent Mode**



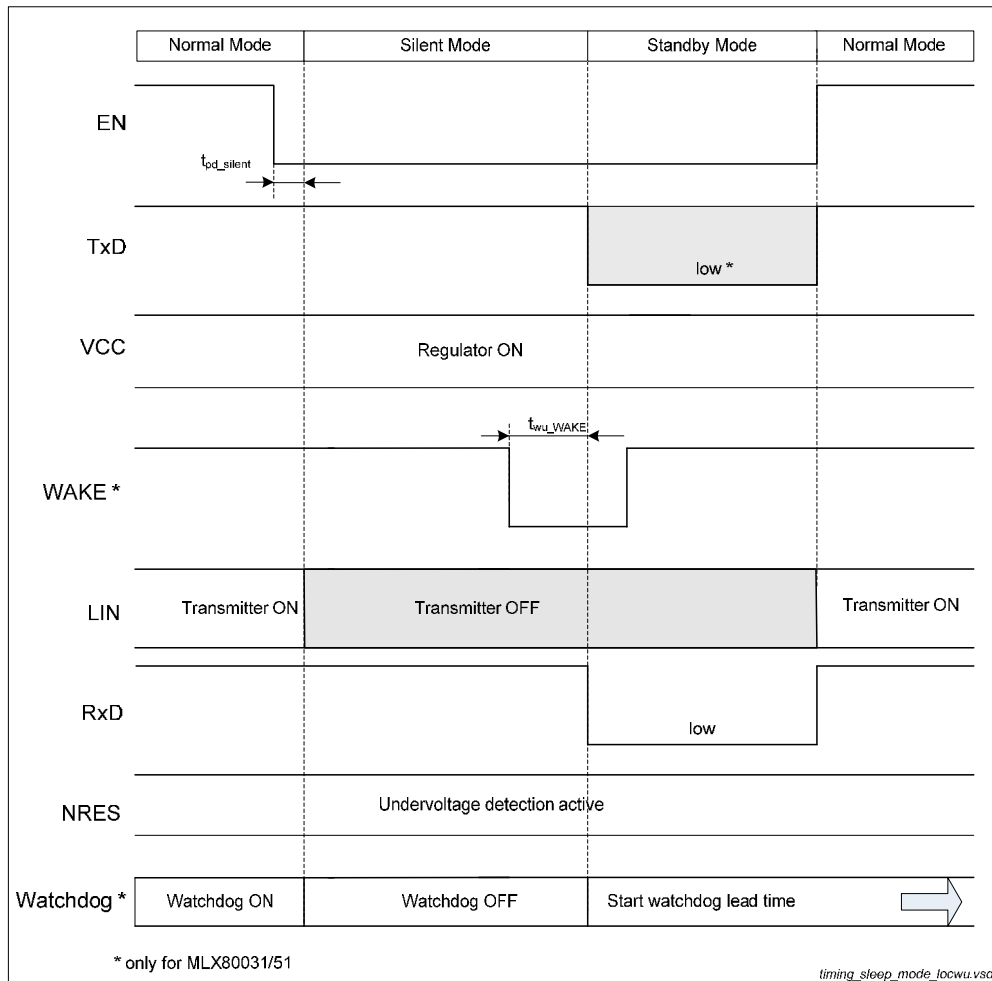

**Figure 7 Local Wake-up from Silent Mode via WAKE**

### 4.5. Sleep Mode

The most power saving mode of the MLX8003x/5x is the Sleep Mode. The MLX8003x/5x offers two procedures to enter the sleep mode:

- The mode is selected from normal mode with a falling edge on EN in combination with TxD = L.
- If the MLX8003x/5x is in Standby Mode after power-on or wake-up, a sleep counter is started and switches the transceiver into Sleep Mode after the specified time (typ. 350ms) even when the microcontroller of the ECU will not confirm the normal operation by setting the EN pin to logic HIGH. This new feature allows faulty blocked LIN nodes to reach always the most power saving mode.

Being in Sleep Mode the voltage regulator switched off in order to minimize the current consumption of the complete LIN node. The transmitter is disabled and the pin RxD is disconnected from the receive path and is low (follows VCC). The slave termination resistor (LIN pull up resistor with decoupling diode between pins LIN and VS) is disconnected, only a weak current source is applied to the LIN bus (see chapter 8 fail-safe features)

To exit the Sleep Mode with one of the following condition(s):

1. Remote (all versions) or local wake up request (MLX80031/51 only) -> Switch to Standby Mode

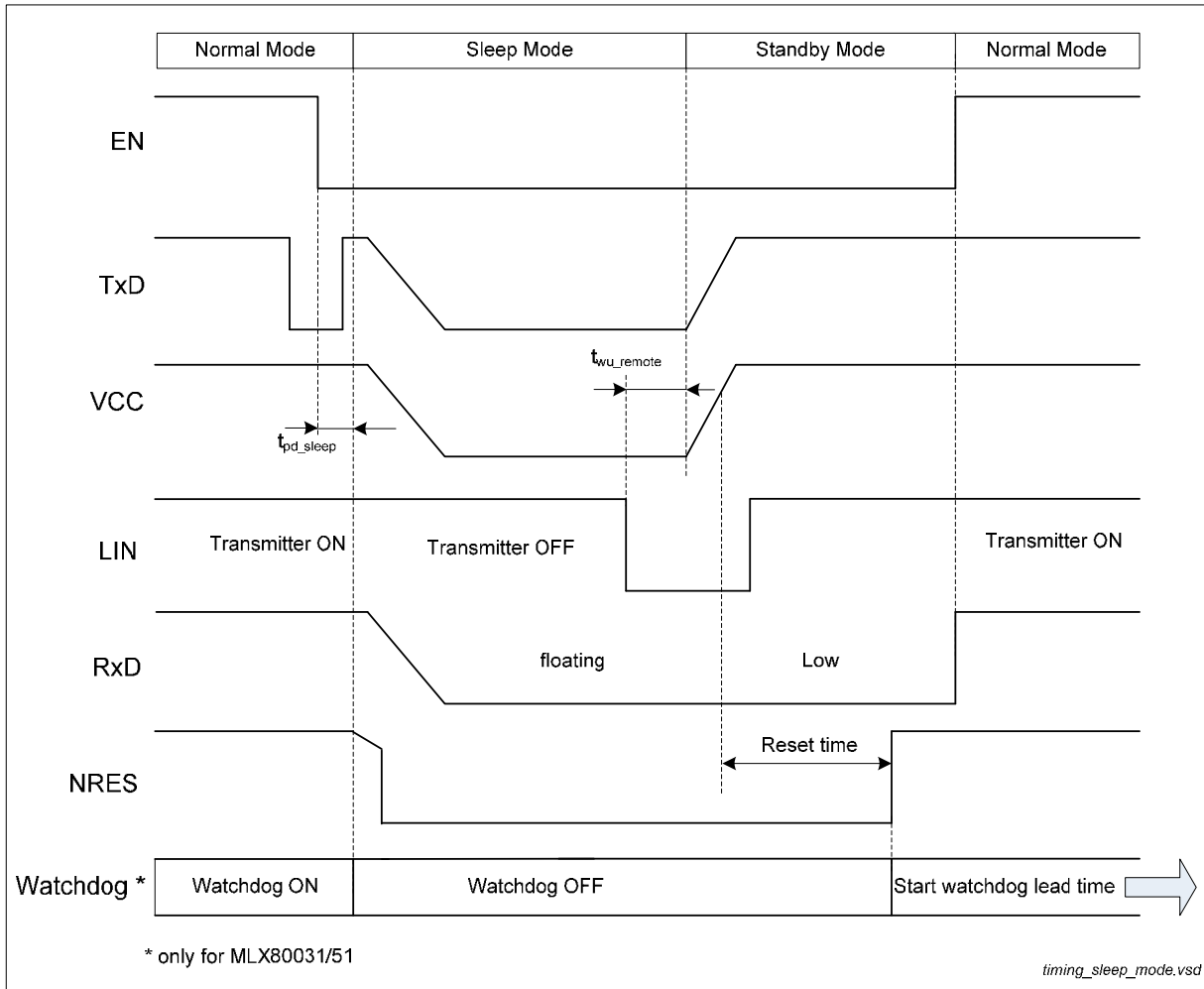

**Figure 8: Remote wake-up from Sleep Mode**

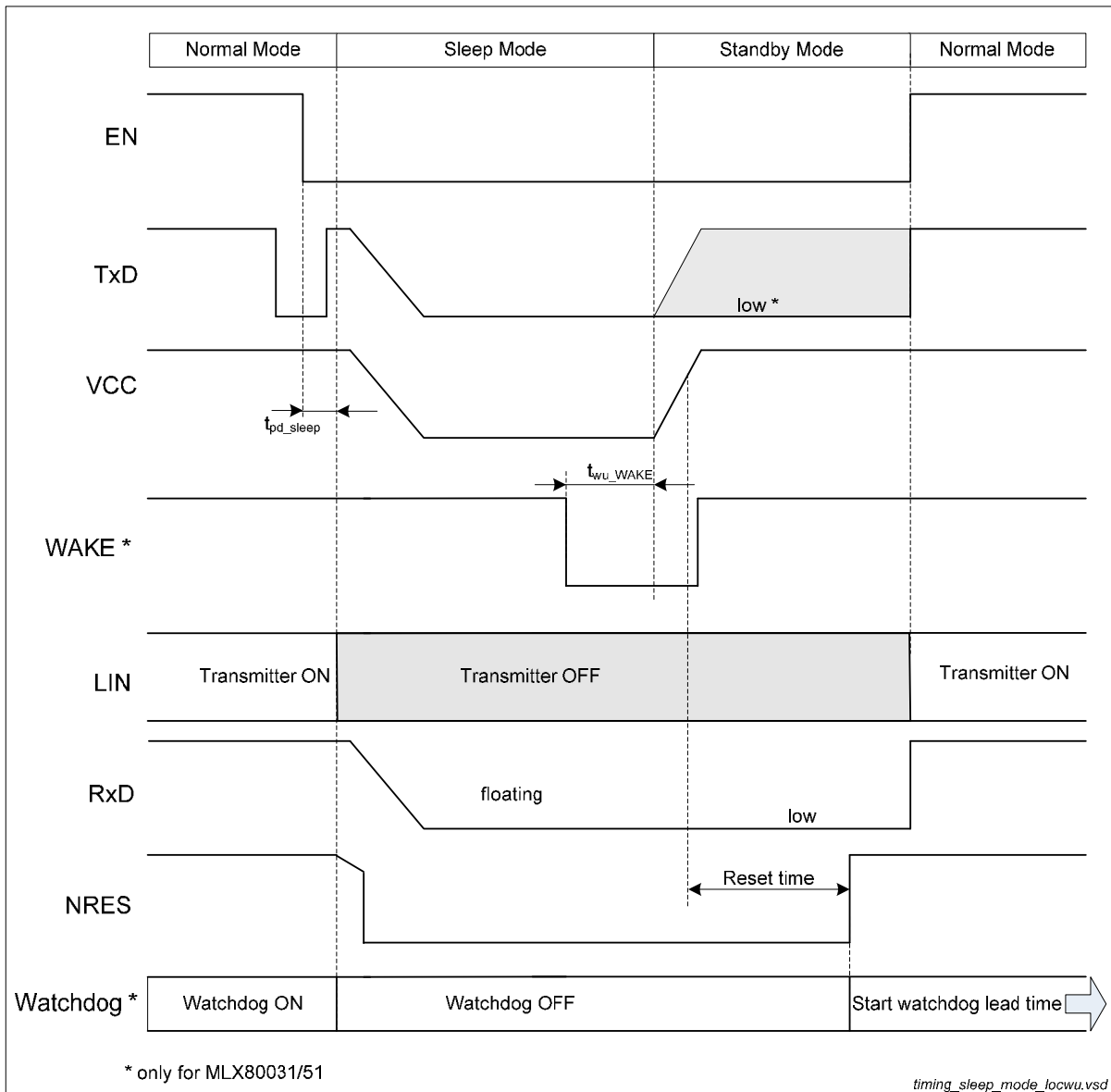

**Figure 9: Local wake-up from Sleep Mode**

### 4.6. Init-State

This is an intermediate state, which will pass through after switch on of VS or after undervoltage detection VS with  $VS < V_{SUVR\_ON}$ . The internal supply voltage  $V_{aux}$  ramp up and the initial readout procedure off zenerzap storage are started. On the end of this phase the VCC voltage definition and the definition of MLX8003x5x version is established. This Init-State changes to Standby Mode with the start of VCC regulator.

## 5. Wake Up Procedures

The MLX80030/50 versions offer only remote wake-up:

- After a falling edge on the LIN bus followed by a dominant voltage level for longer than the specified value ( $t_{wu\_remote}$ ) and a rising edge on pin LIN will cause a remote wake up. The device switches to Standby Mode and the wake-up request is indicated by an active LOW on pin RxD.

The MLX80031/51 versions offer three wake-up procedures:

- In applications with continuously powered ECU a wake up via mode transition to normal mode is possible (see chapter 4.3 Normal Mode)
- Remote wake-up via LIN bus traffic  
After a falling edge on the LIN bus followed by a dominant voltage level for longer than the specified value ( $t_{wu\_remote}$ ) and a rising edge on pin LIN will cause a remote wake up (see)
- Local wake-up via a negative edge on pin WAKE  
A negative edge on the pin WAKE and a dominant voltage level for longer than the specified time ( $t_{wu\_WAKE}$ ) will cause a local wake-up. The current for an external switch has to be provided by an external pull up resistor  $R_{WK}$ . For a reverse current limitation in case of a closed external switch and a negative ground shift or an ECU loss of ground a protection resistor  $R_{WK\_prot}$  between pin WAKE and the switch is recommended.
- Local wake-up via a positive edge on pin KL15  
A positive edge on the pin KL15 followed by a high voltage level for a time period  $t_{wu\_KL15} > 250\mu s$  results in a local wake-up request. The MLX80031/51 switches to the Standby Mode. The long debouncing time on KL15 suppress unintentional transients in a certainly way. A high level on KL15 has no influence of switching between modes with EN input. Before a new local wake-up request via KL15 can be started, KL15 have to be switched to low level for a time  $> 250\mu s$ .

### 5.1. Wake Up Source Recognition in MLX80031/51

The device can distinguish between a local wake-up event (pin WAKE or pin KL15) and a remote wake-up event. The wake-up source flag is set after a local wake-up event and is indicated by an active LOW on pin TxD.

The wake-up flag can be read if an external pull up resistor towards the microcontroller supply voltage has been added and the MLX80031/51 is still in standby mode:

- LOW level indicates a local wake-up event
- HIGH level indicates a remote wake up event

The wake-up request is indicated by an active LOW on pin RxD and can be used for an interrupt.

When the microcontroller confirms a normal mode operation by setting the pin EN to HIGH, both the wake-up request on pin RxD as well as the wake-up source flag on pin TxD are reset immediately.

## 6. Functionality

### 6.1. RESET behaviour of MLX8003x/5x

The MLX8003x/5x contains a reset unit which secures the correct initialization and generation of the reset signal. The *NRES* pin outputs the reset state of the MLX8003x/5x. The POR timer will be started if  $V_S$  is switched on and  $V_{CC} > V_{RES}$  threshold. After the time  $t_{Res}$  the *NRES* output is switched from low to high.

The reset unit combines a  $V_{CC}$  low voltage detection unit with fixed reset timer. This output is switched from low to high if  $V_S$  is switched on and after the time  $t_{Res}$  is  $V_{CC} > V_{RES}$ .

All conditions which cause a drop of the  $V_{CC}$  voltage will be detected from the low voltage reset unit which generates a reset signal. The MLX8003x/5x will be reinitialized if the  $V_{CC}$  voltage rises above the low voltage limit.

If the voltage  $V_{CC}$  drops below  $V_{RES}$  then the *NRES* output is switched from high to low after the time  $t_r$  has been reached. For these reason short breaks of the  $V_{CC}$  voltage and uncontrolled reset generations will be inhibited.

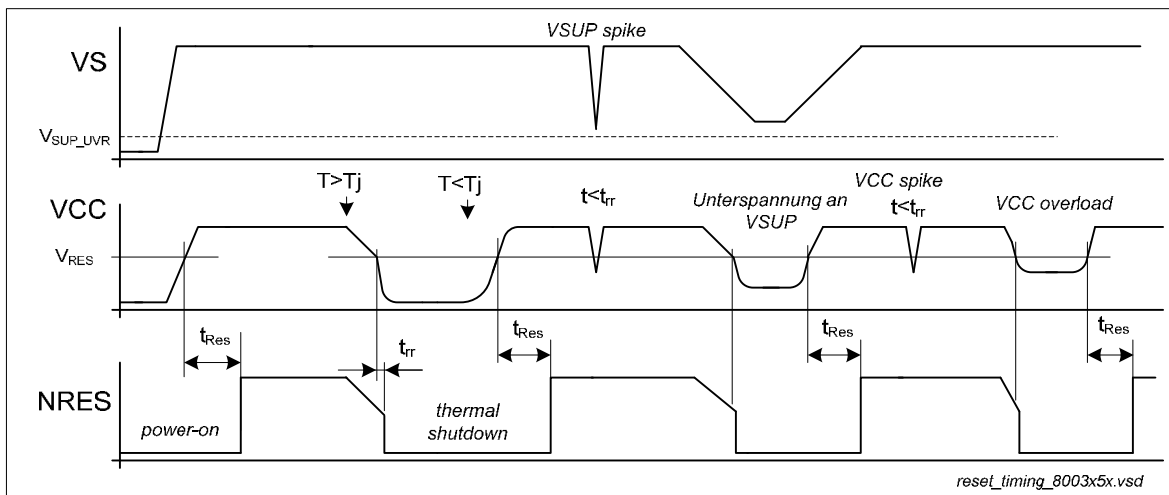

Figure 10: VCC reset behavior

The MLX80031/51 version combines the reset behaviour described at point above with a window-watchdog unit.

The *NRES* pin outputs the reset state as well as the watchdog condition. The POR timer will be started if  $V_{SUP}$  is switched on and  $V_{CC} > POR$  threshold. After the time  $t_{Res}$  the RESET output is switched from low to high.

The watchdog is disabled during this POR procedure. After the POR delay the *NRES* output is switched from low to high and the watchdog starts. In normal mode the *NRES* pin outputs the status of the window watchdog.

### 6.2. Thermal Shutdown

If the junction temperature  $T_J$  is higher than  $T_{JSHD}$ , the MLX8003x/5x will be switched from any mode into Standby Mode. During TSD all functions are switched-off. The transceiver is completely disabled; no wake-up functionality is available.

If  $T_J$  falls below the thermal recovery temperature  $T_{JREC}$ , the MLX8003x/5x will resume operation starting from Standby Mode. If  $EN=H$  at recovery, chip switches to NORMAL after  $V_{CC} > V_{RES}$  and  $t_{Res}$ . SBY-timeout timer is disabled during TSD.

### 6.3. *VS under voltage reset*

The under voltage detection unit prevents an undefined behaviour of the MLX8003x/5x under low voltage condition ( $V_S < V_{SUVR\_ON}$ ). If  $V_S$  drops below  $V_{SUVR\_ON}$ , the under voltage detection becomes active and the IC will be switched from every state to Init-State followed by Standby Mode with the same behaviour like after  $V_S$  power-on. With the following increase of  $V_S$  above  $V_{SUVR\_OFF}$  the MLX8003x/5x remains in Standby Mode and the voltage regulator starts with the initialization sequence ( $V_{CC}$  available). If  $EN=H$  at power-up, the chip switches to NORMAL after  $V_{CC} > V_{RES}$  and  $t_{res}$ .

**Remark:** In case  $V_S$  drops below 5V but still remains above  $V_{SUVR\_ON}$ ,  $V_{CC}$  follows  $V_S$ .  $V_{CC}$  is switched off during  $V_S$  Undervoltage reset.

### 6.4. *LIN-Transceiver*

The MLX8003x/5x has an integrated bi-directional bus interface device for data transfer between LIN bus and the LIN protocol controller.

The transceiver consists of a driver with slew rate control, wave shaping and current limitation and a receiver with high voltage comparator followed by a debouncing unit.

#### **Transmit Mode**

During transmission the data at the pin TxD will be transferred to the LIN driver to generate a bus signal. To minimize the electromagnetic emission of the bus line, the LIN driver has an integrated slew rate control and wave shaping unit.

Transmitting will be interrupted in the following cases:

- Sleep Mode
- Silent Mode
- Thermal Shutdown active
- Power on Reset

The recessive LIN bus level is generated from the integrated 30k pull up resistor in serial with an active diode. This diode prevents the reverse current of  $V_{LIN}$  during differential voltage between  $V_S$  and LIN ( $V_{LIN} > V_S$ ).

No additional termination resistor is necessary to use the MLX8003x/5x in LIN slave nodes. If this ICs are used for LIN master nodes it is necessary that the LIN pin is terminated via an external 1k $\Omega$  resistor in series with a diode to VBAT.

#### **Receive Mode**

The data signals from the LIN pin will be transferred continuously to the pin RxD. Short spikes on the bus signal are suppressed by the implemented debouncing circuit.

#### **Slew Modes and Data rates**

The MLX8003x/5x consists a **constant slew rate** transceiver which means that the bus driver works with a mode depended slew rate. In normal mode the slew rate is typical 1.6 V/ $\mu$ s (max. baud rate 20kbit/s) and in low slew mode typical 0.8 V/ $\mu$ s. The lower slew rate in low slew mode associated with a baud rate of 10.4kbit/s improves the EME behaviour.

The LIN transceiver of MLX8003x/5x is compatible to the physical layer specification according to LIN 2.x specification for data rates up to 20kbit/s and the SAE specification J2602 for data rates up to 10.4kbit/s.

The constant slew rate principle is very robust against voltage drops and can operate with RC- oscillator systems with a clock tolerance up to  $\pm 2\%$  between 2 nodes.

### ***Low Slew Mode***

In this mode the slew rate is switched from the normal value of typical 1.6V/μs to a low value of typical 0.8V/μs. This mode is optimized to send with a maximum baud rate of 10.4kbit/s (acc. to SAE J2602). Because of this reduction of the slew rate the EME behaviour is improved especially in the frequency range of 100 kHz to 10MHz.

### ***6.5. Voltage Regulator***

The MLX8003x/5x has an integrated low drop linear regulator with a p-channel-MOSFET as driving transistor. This regulator outputs a voltage of 3.3V/5V ±2% and a current of ≤70mA within an input voltage range of 6V ≤ V<sub>SUP</sub> ≤ 18V. The current limitation unit limits the output current for short circuits or overload to 130mA respectively drop-down of the V<sub>CC</sub> voltage.

### 7. Window-Watchdog (only MLX80031/51)

The integrated window watchdog unit observes the correct function of the connected Microcontroller. The required timing can be programmed with an external resistor connected to the pin  $RB_{WD}$ . This resistor defines together with an internal capacitor the watchdog oscillator frequency. The watchdog is re-triggered by the Microcontroller via the NWDI input. The watchdog status is represented by the NRES pin. Negative edges on NWDI reset the watchdog timer. If no pulse is received at NWDI, the MLX80051/31 generates low pulses on the NRES output with a pulse width of  $t_{WDres}$  and a period of  $t_{WDper}$ .

#### 7.1. MLX80031/51 Watchdog Behaviour

After power-on and elapsed reset time  $t_{res}$ , the window watchdog starts operation with a rising edge on pin NRES. This start is independent from Standby or Normal Mode.

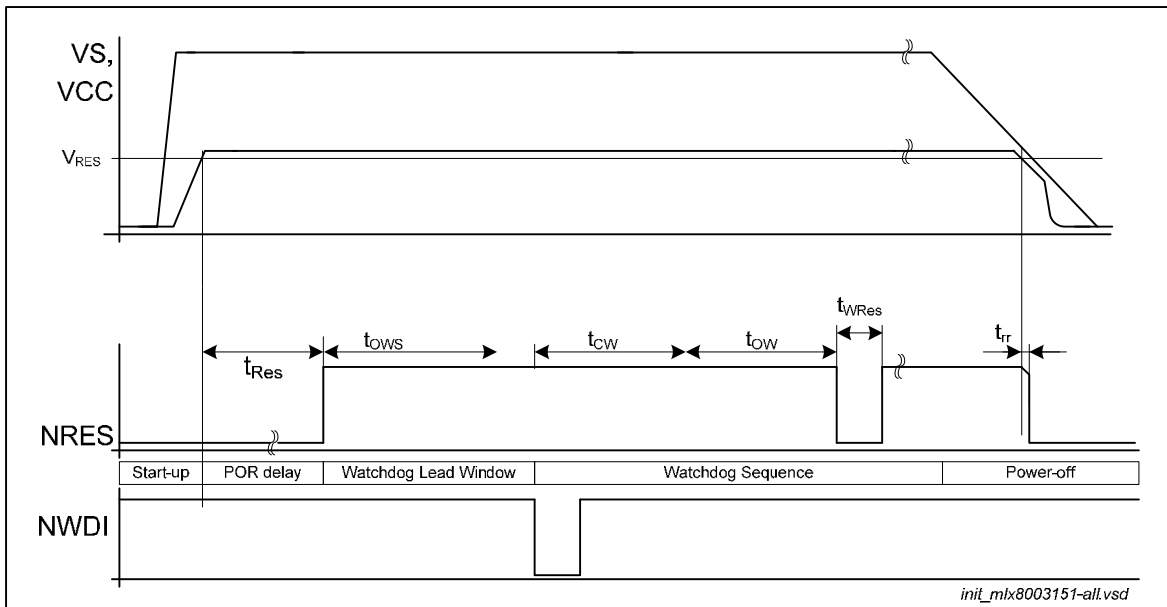

**Figure 11: MLX80031/51 Watchdog behavior**

In case of Silent or Sleep Mode are left via remote wake-up (LIN) or local wake-up (WAKE or KL15), the window watchdog starts immediately after entering Standby Mode.

After  $t_{res}$  the window watchdog unit starts with the Lead Time State. At this state the watchdog clock periods ( $1/f_{wdosc}$ ) are counted 7895(=nlead) times. A negative edge on NWDI pin within this lead time stops the lead counter and activates the Close Window State with  $ncw=1053$ . Thereafter follows the Open Window State with counter start value of  $now=1105$ . In case the lead counter elapses, the watchdog enters the Reset State and starts the reset timer with time  $t_{res}$ .

Close Window State and Open Window State are the normal states of the window watchdog. At each of these states runs a counter with the watchdog clock signal. The CWT counter runs always to the end. The watchdog will only trigger correctly if the NWDI trigger signal arrives within the Open Window State.

A NWDI trigger pulse outside the open window generates a reset condition and the NRES output switches to low for the time  $t_{WDres}$  (see Figure 12).



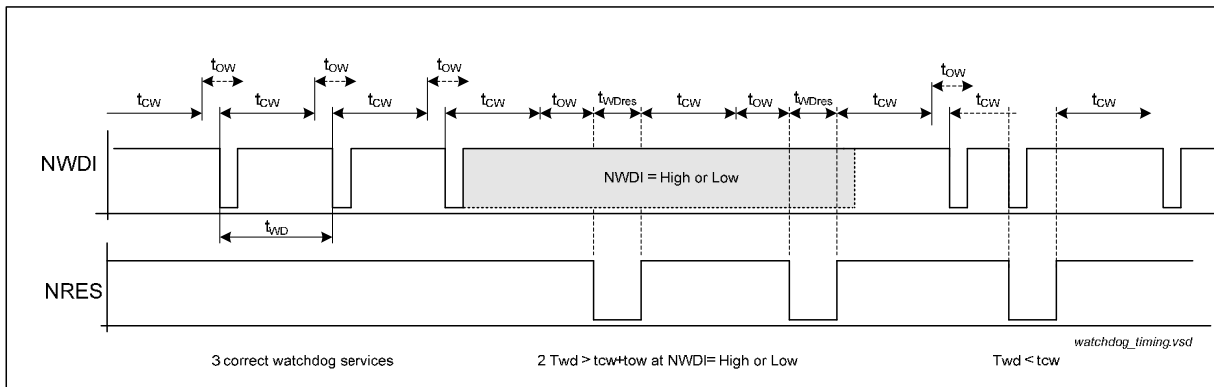

**Figure 12: Watchdog timing**

## 7.2. All watchdog start-up scenarios

### 7.2.1. After power-on and initialization

Watchdog started after VCC ramp up and the finishing of reset timer (typ. 4ms) with Lead Time State. MLX80031/51 is in Standby or Normal Mode

### 7.2.2. Wake up indicated transition to Standby Mode from Sleep or Silent Mode

Watchdog started immediately with activating of Standby Mode (SBY\_MODE = 1). By transition from Sleep Mode the VCC regulator ramps up also and the reset timer starts. The reset timer has in this case no influence for the watchdog start.

### 7.2.3. Undervoltage reset on VCC on Normal Mode or Silent Mode

MLX80031/51 goes to Standby Mode. Running watchdog process is stopped and cleared. With active undervoltage reset the signal the output pin NRES goes to low. With leaving of undervoltage reset start the reset timer (4ms) and after them start a new watchdog procedure.

### 7.2.4. EN indicated transition from Silent Mode to Normal Mode

Mode control goes from Silent Mode to Normal Mode. Watchdog started immediately with activating of Normal Mode with Close Window State.

### 7.3. Calculation of Watchdog Period

The RC-oscillator of MLX80031/51 which generates the responsible timing of the watchdog has a tolerance of  $\pm 15\%$ . This has the consequence that also the watchdog window times  $t_{CW}$  and  $t_{OW}$  variants with this tolerance.

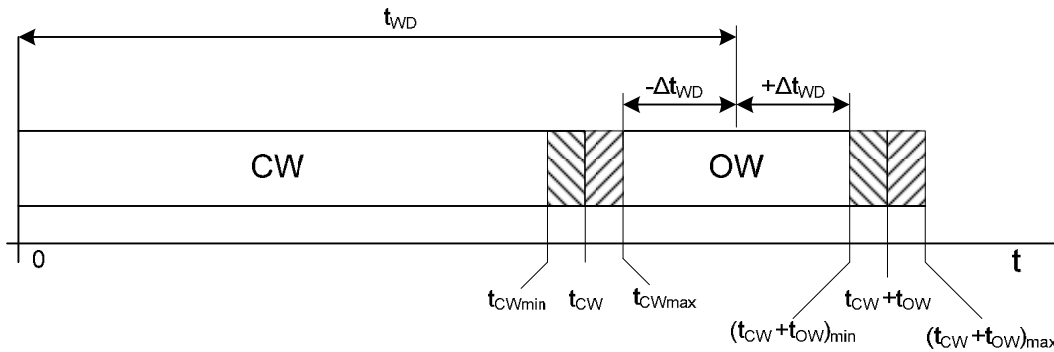

**Figure 13: Watchdog open and close window tolerances**

The ideal watchdog period can be calculated with:

$$t_{WD\_id} = t_{CW} + \frac{1}{2} * t_{OW}$$

The average value  $t_{WD}$  of the real usable watchdog trigger time under consideration of the oscillator tolerance is:

$$t_{WD} = (t_{CW\ min} + t_{OW\ min} + t_{CW\ max})/2 \quad [EQ1]$$

The allowed tolerance  $\Delta t_{WD}$  is:

$$\Delta t_{WD} = (t_{CW\ min} + t_{OW\ min} - t_{CW\ max})/2 \quad [EQ2]$$

With the definition of  $t_{CW} = ncw * (1 \pm TOL) * t_{WDOSC}$  and  $t_{OW} = now * (1 \pm TOL) * t_{WDOSC}$  from [EQ1]  $t_{WD}$  can be calculated with:

$$t_{WD} = t_{WDOSC} (2 * ncw + now * (1 - TOL)) / 2 \quad [EQ3]$$

and with [EQ2]:

$$\Delta t_{WD} = t_{WDOSC} (now * (1 - TOL) - 2 * TOL * ncw) / 2 \quad [EQ4]$$

The variation  $\Delta t_{WD}$  will be normalized to the mean value  $t_{WD}$  and both counter values set in a relationship of  $a = now/ncw$ , then follows for the relative deviation:

$$t_{WDTOL} = \frac{a * (1 - TOL) - 2 * TOL}{2 + a * (1 - TOL)} \quad [EQ5]$$

The watchdog trigger time as well as the tolerance depends only on the oscillator frequency respectively the period  $t_{WDOSC}$ , if there are fixed values for both counters ( $ncw$  and  $now$ ) and oscillator tolerance.

Implemented in MLX80031/51 is a precision RC oscillator with a tolerance of  $TOL = \pm 15\%$ . Combined with the relation of counter values  $a = 1.04$  reached them a tolerance of trigger time of  $\pm 20\%$ .

**Table 9: Parameters of Window Watchdog**

Symbol	Parameter	Value
TOL	Tolerance WD oscillator	±15%
ncw	Close window counter	1053
now	Open window counter	1105
t <sub>WDTOL</sub>	Tolerance WD-trigger time	±20%

With the predefined counter values (ncw and now) and the oscillator tolerance TOL are the trigger time of watchdog and them tolerance only be calculated by the selection of oscillator frequency, or their period  $t_{WDOSC}$ . For the used precision RC-oscillator the oscillator period is shown as a linear function of the external resistor  $RB_{WD}$ .

$$t_{WDOSC} [\mu s] = 0.3486 \cdot RB_{WD} [k\Omega] + 1.117 \quad [EQ6]$$

The trigger period can be calculated with the help of EQ3 together with Table 9 – Parameter of Window Watchdog

$$t_{WD} [ms] = 0.53078 \cdot RB_{WD} [k\Omega] + 1.70 \quad [EQ7]$$

Or convert to  $RB_{WD}$ :

$$RB_{WD} [k\Omega] = 1.883 \cdot t_{WD} [ms] - 3.20 \quad [EQ8]$$

Some samples of different  $RB_{WD}$  values and the corresponding watchdog times:

**Table 10: Window Watchdog Timing Selection**

$RB_{WD}$ [kΩ]	$t_{WDOSC}$ [μs]	Lead Time $t_{LEAD}$ [ms]	Close Window $t_{CW}$ [ms]	Open Window $t_{OW}$ [ms]	Trigger Period $t_{WD}$ [ms]
20	8.09	63.9	8.52	8.94	12.32
30	11.58	91.4	12.19	12.79	17.62
51	18.90	149.2	19.90	20.88	28.77
75	27.26	215.2	28.71	30.12	41.51
100	35.98	284.0	37.88	39.75	54.78
120	42.95	339.1	45.23	47.46	65.40
150	53.41	421.6	56.24	59.01	81.32

### Short or open circuit on $RB_{WD}$

The MLX80031/51 can detect a short circuit against GND on the  $RB_{WD}$  pin or an open  $RB_{WD}$  pin. If on pin a resistor  $RB_{WD} < 330\Omega$  or  $RB_{WD} > 10M\Omega$  detected, then the MLX80031/51 checks during the initialization phase a fail-safe state. The watchdog oscillator will be set in a fail-safe mode with an oscillator period of about 50μs.

## 8. Fail-safe features

### **Loss of battery**

If the ECU is disconnected from the battery, the LIN bus pin is in high impedance state. There is no impact to the bus traffic and to the ECU itself. Reverse current is limited to  $< 20\mu\text{A}$

### **Loss of Ground**

In case of an interrupted ECU ground connection there is no influence to the bus line. The current from the ECU to the LIN bus is limited by the weak pull up resistor of the pin LIN. The slave termination resistor is disconnected in order to fulfil the SAE J2602 requirements for the loss of ground current ( $< 100\mu\text{A}$  @12V).

### **Short circuit to battery**

The transmitter output current is limited to the specified value in case of short circuit to battery in order to prevent high current densities and thermal hot spots in the LIN driver.

### **Short circuit to ground**

If the LIN bus wiring is shorted to negative shifted ground levels, there is no current flow from the ECU ground to the bus and no distortion of the bus traffic occurs.

If the controller detects a short circuit of the LIN bus to ground the transceiver can be set into sleep mode. Additionally the internal slave termination resistor is switched off and only a weak pull up termination is applied to the LIN bus (typ.  $50\mu\text{A}$ ). If the failure disappears, the bus level will become recessive again and will wake up the system even if no local wake up occurs or is possible.

### **Thermal overload**

All MLX8003x/5x versions are protected against thermal overloads. If the chip temperature exceeds the specified value, the transmitter is disabled until thermal recovery and the following recessive to dominant transition on pin TxD. The receiver is still working while thermal shutdown.

### **Undervoltage lock out**

If the battery supply voltage is missing or decreases below the specified value ( $V_{S\_UV}$ ), the transmitter is disabled to prevent undefined bus traffic. While in sleep mode, the MLX8003x/5x enters the Standby Mode if  $V_s$  drops below the internal power on reset threshold.

### **Open Circuit protection**

- The pin TxD provides a pull up resistor to VCC. The transmitter can not be enabled.
- The pin EN provides a pull down resistor to prevent undefined normal mode transitions.
- The pin NWDI provides a pull up resistor to VCC. The window watchdog generates NRES pulse.
- The pin MODE provides a pull down resistor to GND. No influence on window watchdog.
- If the battery supply voltage is disconnected, the pin RxD is floating.
- The pin WAKE provides a weak pull up current towards supply voltage  $V_s$  to prevent local wake-up requests.
- The pin KL15 provides a weak pull down current towards GND to prevent local wake-up requests.

### **Short circuit RxD, NRES against GND or VCC**

Both outputs are short circuit proof to VCC and ground.

### **RBWD short circuit against GND or open**

The watchdog oscillator runs with an internal controlled frequency and guarantees a reset.

## 9. Application Hints

### 9.1. Safe Operating Area

The linear regulator of the MLX8003x/5x operates with input voltages up to 27 V and can output a current of 70 mA. The maximum power dissipation limits the maximum output current at high input voltages and high ambient temperatures. The output current of 70 mA at an ambient temperature of  $T_A = 125^\circ\text{C}$  is only possible with small voltage differences between  $V_S$  and  $V_{CC}$ .

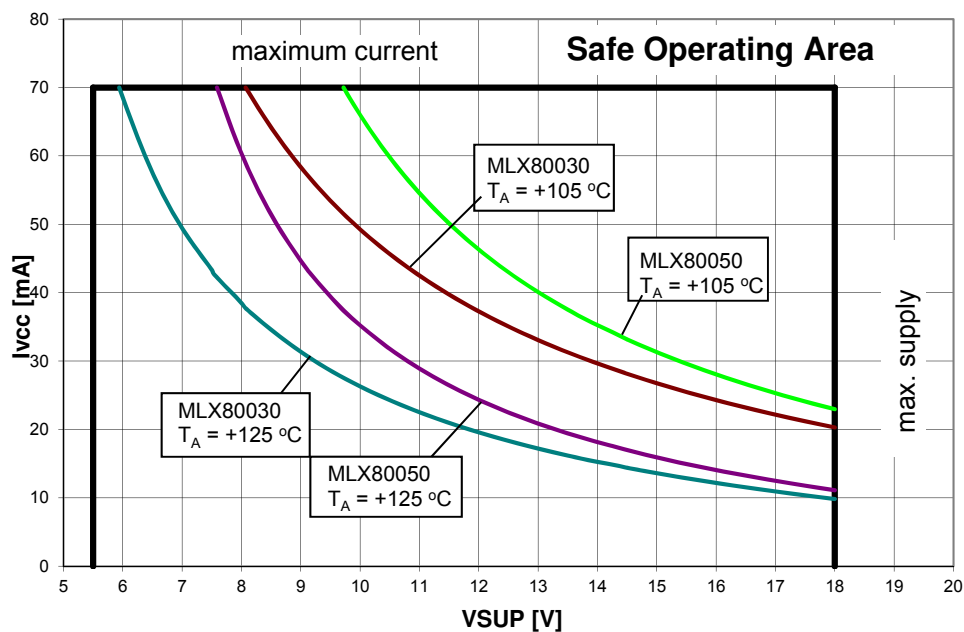

Figure 14: Safe operating area for MLX80030/50 in SOIC-8 for V<sub>sup</sub> up to 18V

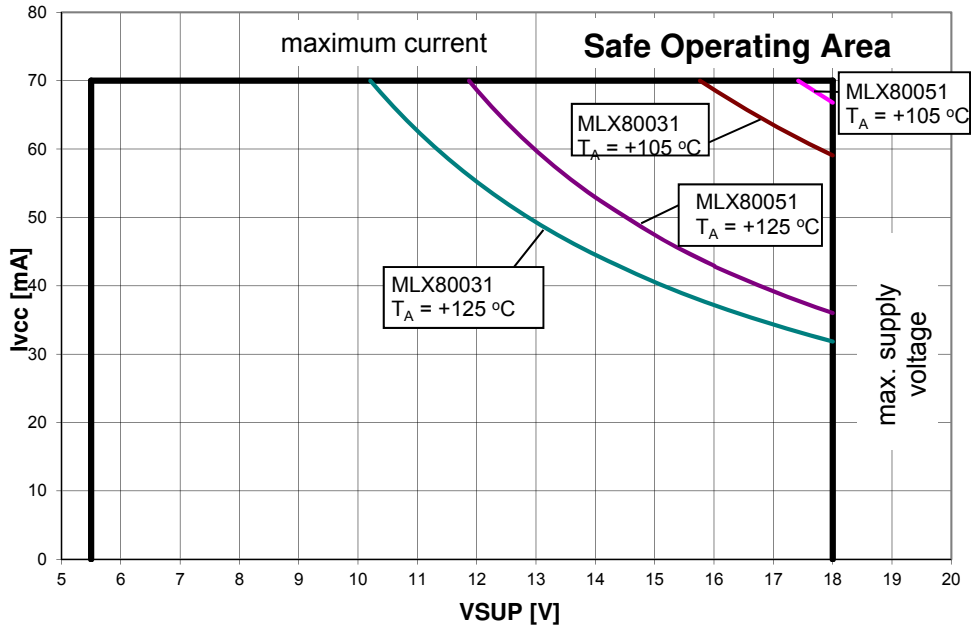

Figure 15: Safe operating area for MLX80031/51 in QFN20 for Vsup up to 18V

## 9.2. Application Circuitry

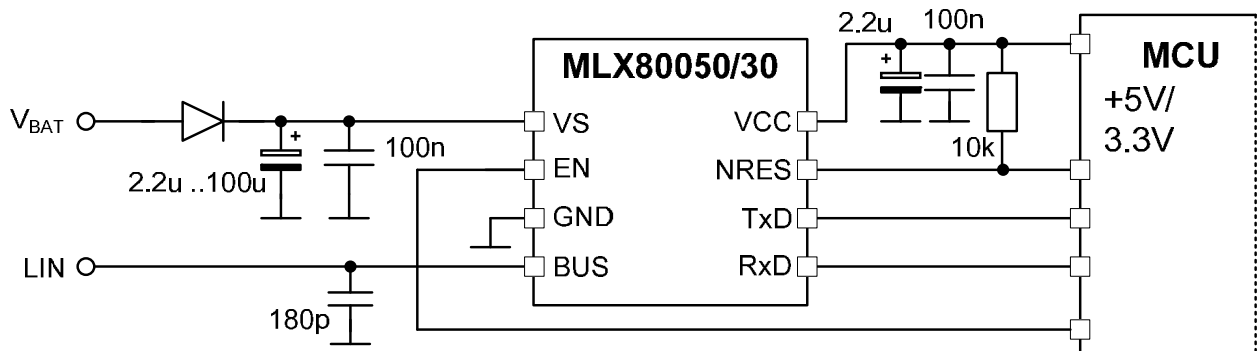

Figure 16: Application circuit with MLX80050 or MLX80030 (slave node)

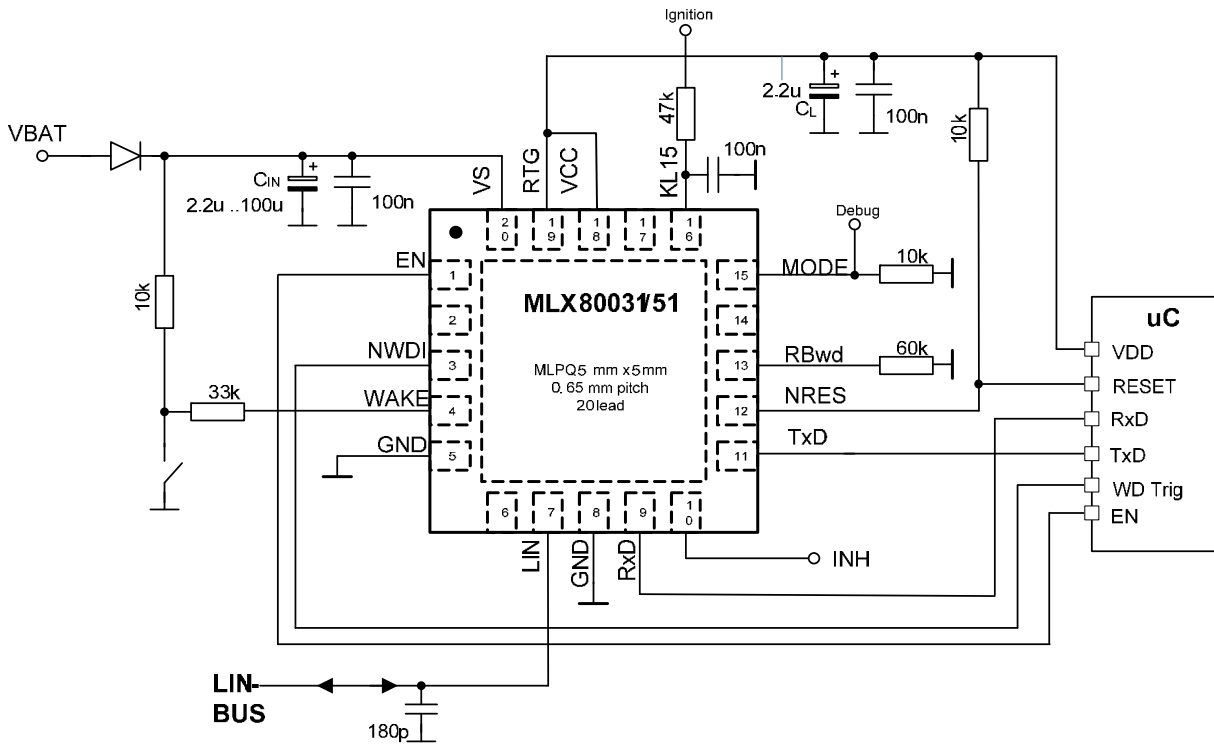

Figure 17: Application circuit with MLX80031 or MLX80051 (slave node)

### 9.2.1. EMI Suppressing

To minimize the influence of EMI on the bus line an 180pF capacitor should be connected directly to the LIN pin (see 0). This EMI-Filter assures that the RF injection into the IC from the LIN bus line has no effect or will be limited.

It is also possible to use LC- or RC-filters. The dimensions of C-L or R-L depend on the corner frequency, the maximum LIN bus capacitance (10nF) and the compliance with the DC- and AC LIN bus parameters.

### 9.2.2. EMC disturbances using the example of MLX80030/50

The MLX80030/50 complies with the standards ISO 7637 part1 and 2 (immunity against transients) and IEC 62132 part 1 and 4 (immunity against RF). The check bases on the document: "Hardware Requirements for LIN, CAN and FlexRay Interfaces in Automotive Applications" V1.0 from 2008-12-10, chapter 5 "EMC Requirements". The tests will be performed on a common test PCB.

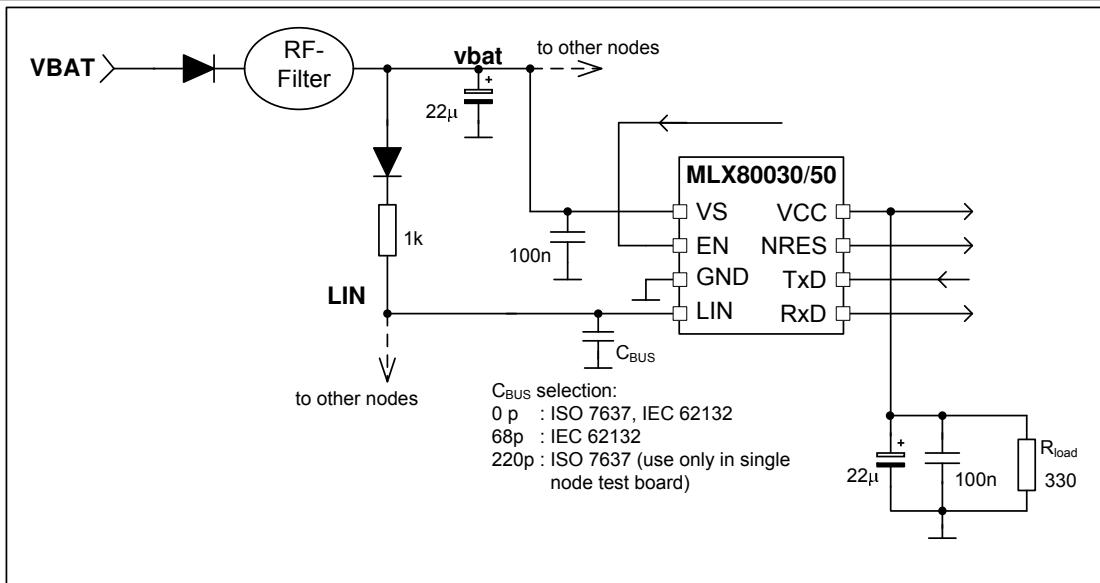

**Figure 18: Part of test circuitry for EMC tests with MLX80030/50**

The standard test board includes 3 LIN nodes with MLX80030/50. The load condition at VCC pin is a compromise between the requirements described in the document named before and the use of MLX80030/50 in practical applications.

The demand of 80% of max load condition means at Normal Mode and Silent Mode 56mA (max. 70mA). In practical application both modes will be used under consideration of save operating area. This leads to a max load value of 15mA or 330 Ohm for Rload.

Failure criterion for all EMC tests is functional status class A. The following table defines the parameter ranges for the pins RxD (dig out), NRES (dig out), VCC (supply out) to fulfil the functional state A at each operating mode.

**Table 11: Parameter ranges for function state A (MLX80050)**

Mode	Transmitter	VCC	RxD	NRES
Normal	ON	Supply ON: 4.75V .. 5.25V	High and Low state with Vcc ±0.9V	High state: min level: Vcc – 1V
Silent	OFF	Supply ON with reduced load 4.75V .. 5.25V	High state: min level: Vcc – 1V	High state: min level: Vcc – 1V
Sleep	OFF	Supply OFF: 0V .. 0.9V	no evaluation	no evaluation



### 10. Mechanical Specification

#### 10.1. SOIC8 package

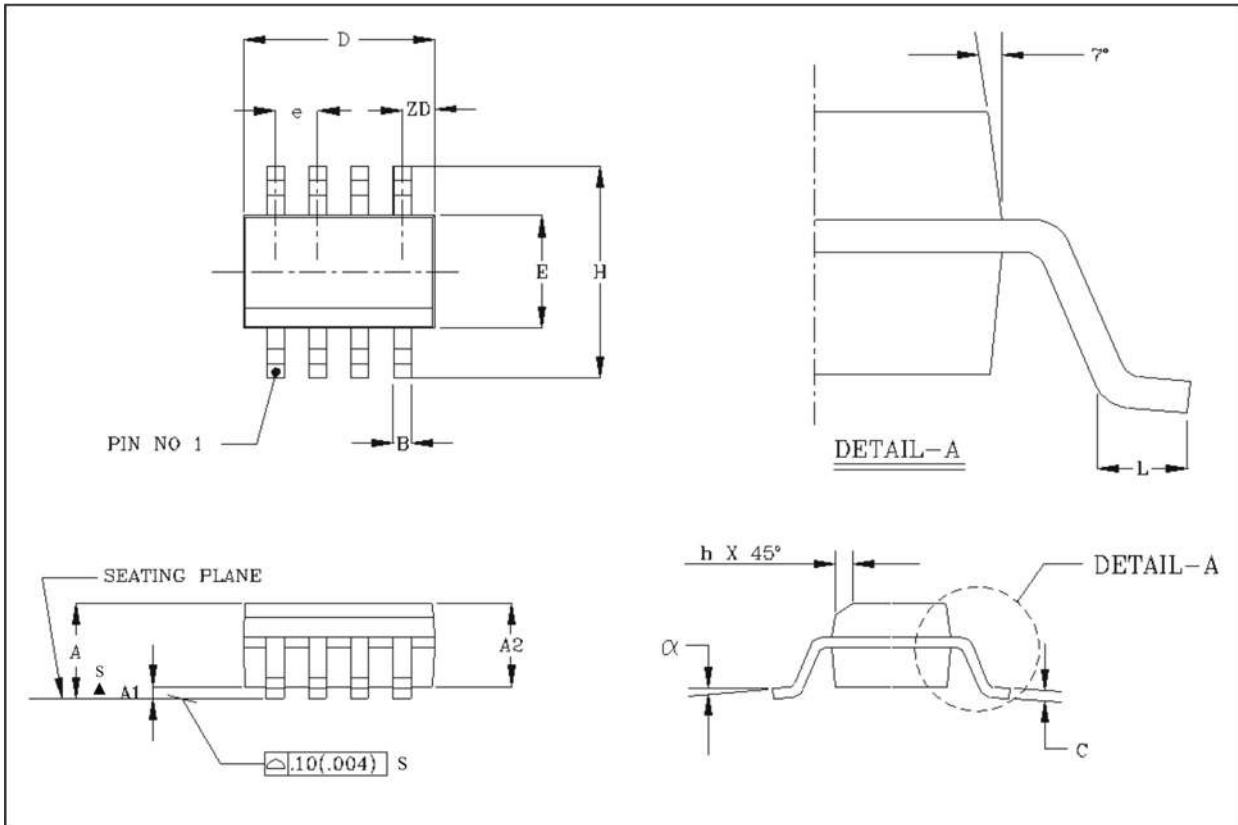

Figure 19: SOIC8 Drawing

Table 12: SOIC8 dimensions

Small Outline Integrated Circuit (SOIC), SOIC 8, 150 mil

	A1	B	C	D	E	e	H	h	L	A	$\alpha$	ZD	A2
All Dimension in mm, coplanarity < 0.1 mm													
min	0.10	0.36	0.19	4.80	3.81	1.27	5.80	0.25	0.41	1.52	0°	0.53	1.37
max	0.25	0.46	0.25	4.98	3.99	1.27	6.20	0.50	1.27	1.72	8°	0.53	1.57

### 10.2. QFN20 5x5 package

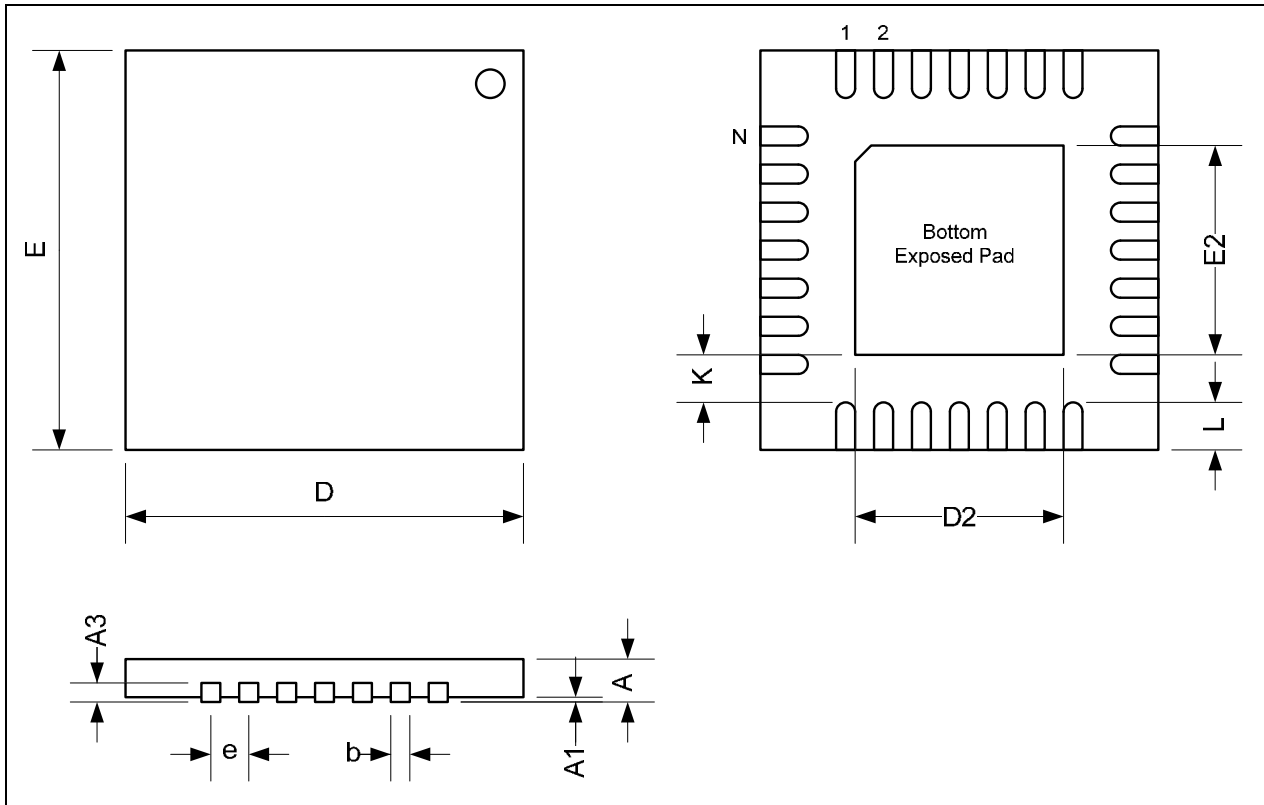

Figure 20: QFN20 Drawing

Table 13: QFN20 Package Dimensions

Symbol	A	A1	A3	b	D	D2	E	E2	e	K	L	N <sup>[3]</sup>	ND <sup>[4]</sup>	NE <sup>[4]</sup>	
min	0.80	0	0.20	0.25	5.00	3.00	5.00	3.00	0.65	0.20	0.45	20	5	5	[1] [2]
max	1.00	0.05		0.35		3.25		3.25			0.65				

[1] Dimensions and tolerances conform to ASME Y14.5M-1994

[2] All dimensions are in Millimeters. All angles are in degrees

[3] N is the total number of terminals

[4] ND and NE refer to the number of terminals on each D and E side respectively

### 11. Revision History

Version	Changes	Remark	Date
001	First Release	1 <sup>st</sup> Release	April 2012
002	<ul style="list-style-type: none"> <li>For TSD added: "If EN=H at recovery, chip switches to NORMAL after VCC&gt;VRES and tres" and "SBY-timeout timer is disabled during TSD"</li> <li>For TSD removed explicit values and kept parameter name only.</li> <li>For Vs_uvr added: "If EN=H at power-up, chip switches to NORMAL after VCC&gt;VRES and tres"</li> <li>Changed state diagram: sleep mode can be left with EN = H (was a L-H transition in A version of the device), refers to Errata 80050AA-07.</li> </ul>		June 2012
003	<ul style="list-style-type: none"> <li>ESD robustness level adapted to Conformance Test Report</li> <li>Static Characteristics adapted to CPK-Values</li> <li>Block Diagram updated</li> <li>Corrected short description of product</li> </ul>		Dec 2012
004	<ul style="list-style-type: none"> <li>Removed 06.05, 09.05, 13.05</li> <li>Changed 05.02 to 200mV (5V) and 100mV (3.3V)</li> <li>Changed 06.03 and 13.03 to 700mV</li> <li>Changed 09.03 to 600mV</li> <li>Added MODE pin to parameter list</li> <li>Changed 15.05 to LL = 2.7V and UL to 3.3V</li> <li>Changed 14.01 to 0.6V at 2mA</li> <li>Changed 08.03 to LL = 30</li> <li>Changed 02.00 to LL = 400 and UL to 1500</li> <li>Changed Tjshd to 155/170/190°C</li> <li>Changed 12.04 and 12.05 UL to 20uA</li> <li>Changed 03.05 to relevance "C" (only for characterization)</li> <li>Added 17.06 Watchdog safety oscillator</li> <li>Changed 3.01 for 80030/31 to UL = 3.201 and UL = 3.399</li> </ul>		Mar 2013
005	<ul style="list-style-type: none"> <li>Corrected value "e" of QFN package data to "0.65"</li> </ul>		Apr 2013
006	<ul style="list-style-type: none"> <li>Changed 15.01</li> <li>Changed 1.03 LL to 40mV</li> <li>Changed 3.09 LL to -135mA and UL to -75mA</li> <li>Changed ESD capability of LIN pin to +/-6kV</li> </ul>		July 2013
007	<ul style="list-style-type: none"> <li>Changed operating voltage to max. 27V</li> <li>Changed table 2, nominal operating voltage, max to 27V</li> <li>Update 3.09: split temperature ranges</li> <li>Changed 12.03 to min: -400μA</li> <li>Changed 12.06 to min: -10μA, max: 50μA</li> <li>Changed 6.04 to typ: 125 kΩ, max: 250 kΩ</li> <li>Changed 12.01 to 80μA</li> </ul>		Feb 2014
008	<ul style="list-style-type: none"> <li>Added condition for thermal resistance</li> </ul>		April 2014

	<ul style="list-style-type: none"><li>• Updated chapter 4.1, tables 7 and 8 for TxD and RxD values depending on the mode and EN = H transition from Sleep Mode to Normal Mode</li><li>• Changed operating voltage to 27V max in application hints 9.1</li><li>• Re-phrased information to EMC compliance in 9.2.2</li><li>• LIN: Changed parameter 12.10 and added parameter 12.12 to Lin spec 2.x and compatible to SAE J2602, split parameter 12.07 into dominant and recessive</li></ul>		
--	---	--	--

### *12. Standard information regarding manufacturability of Melexis products with different soldering processes*

Our products are classified and qualified regarding soldering technology, solderability and moisture sensitivity level according to following test methods:

#### **Reflow Soldering SMD's (Surface Mount Devices)**

- IPC/JEDEC J-STD-020  
Moisture/Reflow Sensitivity Classification for Nonhermetic Solid State Surface Mount Devices (classification reflow profiles according to table 5-2)
- EIA/JEDEC JESD22-A113  
Preconditioning of Nonhermetic Surface Mount Devices Prior to Reliability Testing (reflow profiles according to table 2)

#### **Wave Soldering SMD's (Surface Mount Devices) and THD's (Through Hole Devices)**

- EN60749-20  
Resistance of plastic- encapsulated SMD's to combined effect of moisture and soldering heat
- EIA/JEDEC JESD22-B106 and EN60749-15  
Resistance to soldering temperature for through-hole mounted devices

#### **Iron Soldering THD's (Through Hole Devices)**

- EN60749-15  
Resistance to soldering temperature for through-hole mounted devices

#### **Solderability SMD's (Surface Mount Devices) and THD's (Through Hole Devices)**

- EIA/JEDEC JESD22-B102 and EN60749-21  
Solderability

For all soldering technologies deviating from above mentioned standard conditions (regarding peak temperature, temperature gradient, temperature profile etc) additional classification and qualification tests have to be agreed upon with Melexis.

The application of Wave Soldering for SMD's is allowed only after consulting Melexis regarding assurance of adhesive strength between device and board.

Melexis recommends reviewing on our web site the General Guidelines [soldering recommendation \(http://www.melexis.com/Quality\\_soldering.aspx\)](http://www.melexis.com/Quality_soldering.aspx) as well as [trim&form recommendations \(http://www.melexis.com/Assets/Trim-and-form-recommendations-5565.aspx\)](http://www.melexis.com/Assets/Trim-and-form-recommendations-5565.aspx).

Melexis is contributing to global environmental conservation by promoting **lead free** solutions. For more information on qualifications of **RoHS** compliant products (RoHS = European directive on the Restriction Of the use of certain Hazardous Substances) please visit the quality page on our website: <http://www.melexis.com/quality.aspx>

## 13. Disclaimer

Devices sold by Melexis are covered by the warranty and patent indemnification provisions appearing in its Term of Sale. Melexis makes no warranty, express, statutory, implied, or by description regarding the information set forth herein or regarding the freedom of the described devices from patent infringement. Melexis reserves the right to change specifications and prices at any time and without notice. Therefore, prior to designing this product into a system, it is necessary to check with Melexis for current information. This product is intended for use in normal commercial applications. Applications requiring extended temperature range, unusual environmental requirements, or high reliability applications, such as military, medical life-support or life-sustaining equipment are specifically not recommended without additional processing by Melexis for each application.

The information furnished by Melexis is believed to be correct and accurate. However, Melexis shall not be liable to recipient or any third party for any damages, including but not limited to personal injury, property damage, loss of profits, loss of use, interrupt of business or indirect, special incidental or consequential damages, of any kind, in connection with or arising out of the furnishing, performance or use of the technical data herein. No obligation or liability to recipient or any third party shall arise or flow out of Melexis' rendering of technical or other services.

© 2012 Melexis NV. All rights reserved.

For the latest version of this document, go to our website at  
**[www.melexis.com](http://www.melexis.com)**

Or for additional information contact Melexis Direct:

**Europe, Africa, Asia:**

Phone: +32 1367 0495

E-mail: [sales\\_europe@melexis.com](mailto:sales_europe@melexis.com)

**America:**

Phone: +1 248 306 5400

E-mail: [sales\\_usa@melexis.com](mailto:sales_usa@melexis.com)

ISO/TS 16949 and ISO14001 Certified