

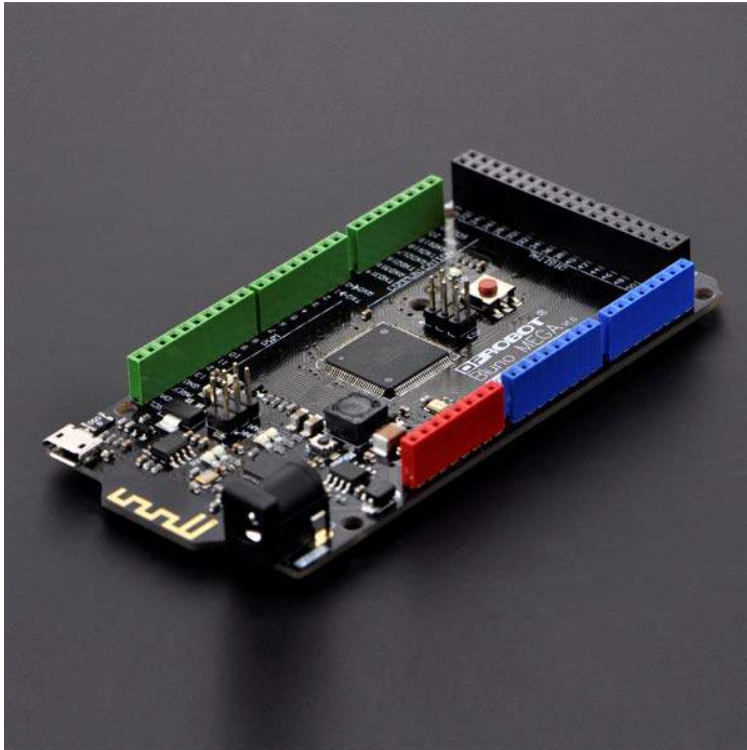

Bluno Mega 2560 (SKU:DFR0323)

From Robot Wiki



Contents

- 1 Introduction
- 2 Specification
- 3 Pin Out
- 4 Supported Android Devices
- 5 Supported Apple Devices
- 6 Tutorial
 - 6.1 More advantages
 - 6.2 The serial port using
 - 6.3 Sample for Bluno Mega2560 connecting to smart phones
 - 6.4 Wireless programming via BLE
 - 6.5 BLE firmware update of Bluno mega2560 ("AT + VERSION" to check the version)

Introduction

Arduino Mega Arduino is the high-end series of the Arduino controller. DFRduino Mega2560 is based on ATmega2560 control chip as the core, with 54 digital I/O (input/output) ports (of which 14 can be used as PWM output), 16 analog input ports and 4 UART (hardware serial ports), using a 16 MHz crystal oscillator.

Embedded bootloader enables the controller to download the program directly via USB without any other external burning device.

Multiple ways of power supply can be free to choose, including the USB power supply and universal power adapter and battery for external power supply.

Open-sourced software and hardware platform, large interacted community, easy development environment and strong control ability, all together making the Arduino become the most popular electronic product development tool currently.

Specification

- Microcontroller : ATmega2560
- Clock frequency: 16MHZ
- Transmission distance: 70m in free space
- Support bluetooth remote update the Arduino program
- Support bluetooth HID
- Support iBeacons
- Support by the AT command to debug the BLE
- Support transparent transmission serial port
- Support the master-slave machine switch
- Support usb update BLE chip program
- Working voltage : +5V
- External input voltage (recommended) : 7V~12V DC
- External input voltage (range) : 6V~20V DC
- Digital I/O outputs: 54 (14 PWM outputs)
- Analog inputs: 16
- I/O current: 40mA
- Flash capacity: 128KB (4k for bootloader)
- Static storage capacity of SRAM: 8KB
- Memory capacity of EEPROM: 4KB
- Size: 108mmx54mm

Pin Out

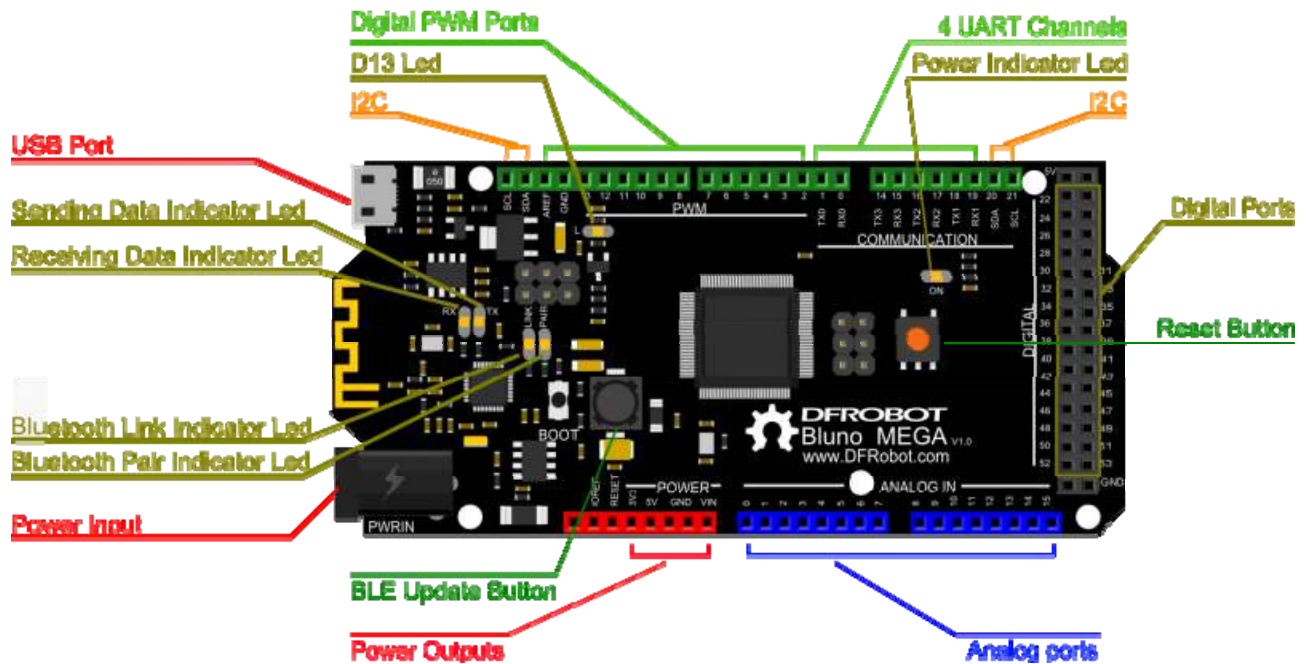

Fig1: Bluno Mega2560 Pin Out

The figure above shows Bluno Mega2560 controller with all the ports, which includes:

- Power: USB power supply or external DC2.1 power supply; automatically disconnect USB power supply when using an external power supply; external power supply transformed as stable 5V through an on-board DC-DC power conversion; current output capacity up to 2A, and USB power supply 5V when the maximum output current is 500mA.
- DC2.1 power input interface, voltage range: 5-23V
- USB interface, power supply and communication
- 2 I2Cs
- 4 UARTs (hardware serial ports)
- 54 digital input/output pins (of which 14 can be used as PWM outputs)
- 16 analog inputs
- 5V and 3.3V output
- A reset button
- A BLE chip firmware update button

Supported Android Devices

Android 4.3 and above systems equipped with Bluetooth 4.0:

- Nexus 4+
- MI 2s
- Samsung Galaxy s4
- Samsung Galaxy note 3

Recommended Android version:

[BLE Android 4.3 ROMs \(Cyanogenmod Stable version\)](#)

<http://download.cyanogenmod.org/?type=stable>

Supported Apple Devices

iOS 7.0+ Devices :

- iPhone 4S+
- iPad 3+
- iPad Mini
- iPod 5th Gen

Tutorial

More advantages

Compared with the first Bluetooth 4.0 integrated Arduino board , Bluno, Bluno Mega2560 not only inherits the advantages of this Bluetooth 4.0 wireless communication function, but also enables more digital and analog ports allowing bigger code storage space. That is to say, you can use Bluno Mega2560 to make more functional DIY works. Also improvement has been done on power supply, with the power input range widened to 5-23V. The board output current capacity has also been greatly increased to 2A (using DC2.1 port to supply power), which is even more fortunate. It means Bluno Mega2560 is able to connect more external sensor modules concurrently. The shield interface is compatible with the Arduino shield interface, as it was previously. Yes, it will undoubtedly become a powerful core board for making creative DIY works.

The serial port using

Bluno Mega2560 and Mega2560 have the same serial port configuration, with only adding a serial port for Bluetooth 4.0 which uses **Serial0** wireless passthrough. Bluno Mega2560 has four serial ports, allowing concurrently connecting 4 communication modules.

Arduino language provides some functions that can be used for operating Bluno Mega2560 serial ports. Taking Serial port 0 as an example, the operation functions are Serial.begin (),

Serial.read(), Serial.print() and Serial.println(). The other three serial port usages are the same as Serial port 0, like that all the operations functions of Serial port 2 are serial2.begin(), serial2.read(), serial2.print() and serial2.println().

Sample for Bluno Mega2560 connecting to smart phones

Please refer to Sample for Bluno connecting to smart phones

Wireless programming via BLE

Please refer to Wireless programming via BLE of Bluno

BLE firmware update of Bluno mega2560 ("AT + VERSION" to check the version)

Please refer to BLE firmware update of Bluno