

## 1.5 A Step-Down DC/DC Converter with Build-in Inductor

### FEATURES

**Built-in inductor and transistors**

**Operating Input Voltage Range:** 2.7 V ~ 6.5 V

**Output Voltage Range:** 0.8 V ~ 3.6 V

**Output Voltage Error:**  $\pm 2\%$

**Output Current:** 1500 mA

**High Efficiency:** 92% ( $V_{IN} = 5.0\text{ V}$ ,  $V_{OUT} = 3.3\text{ V}$ )

**Oscillation Frequency:** 3.0 MHz

**Maximum Duty Cycle:** 100%

**Operating Modes:** PWM, PWM/PFM auto select

**Functions:** Chip Enable, Build-in Current Limit, High Speed Load Capacitor Discharge, Soft start, thermal shutdown

**Operating Ambient temperature:**  $-40 \sim +85^{\circ}\text{C}$

**Package:** USP-9B01

**EU RoHS Compliant, Pb Free**

### APPLICATION

- Mobile Phones
- Bluetooth headsets
- Digital home appliances
- Office automation equipment
- Various portable equipment

### DESCRIPTION

The IXD9213/14 series are synchronous step-down DC/DC converters with an inductor and a control IC in one tiny (2.5 x 3.2 x 1.0 mm) package. A stable

power supply with an output current of 1500 mA requires only two capacitors connected externally.

Operating voltage range is from 2.7 V to 6.5 V. Output voltage is internally set in a range from 0.8 V to 3.6 V. The device operates at 3.0 MHz switching frequency, and includes 0.14  $\Omega$  P-channel switching transistor and 0.10  $\Omega$  N-channel transistor for synchronous rectification. The IXD9213 series operate in a fast transient response PWM mode, while IXD9214 series automatically switching between PWM/PFM modes.

An automatic PWM/PFM switching allows fast response to the load changes, low ripple noise, and high efficiency over the full range of loads.

CE pin allows set device into stand-by mode with a current consumption below 1.0  $\mu\text{A}$ .

The built-in Under Voltage Lockout (UVLO) function forces the internal switching transistor OFF when input voltage becomes less than 2.0 V

IXD9213/14 series have a fast soft start function internally set at 0.3 ms (typ).

IXD9213/14 series have also fast load capacitor  $C_L$  auto discharge function, which allows fast  $C_L$  discharge through switch located between the  $L_X$  and  $V_{SS}$  pins. When the devices enter stand-by mode, output voltage quickly returns to the  $V_{SS}$  level because of this function.

### TYPICAL APPLICATION CIRCUIT

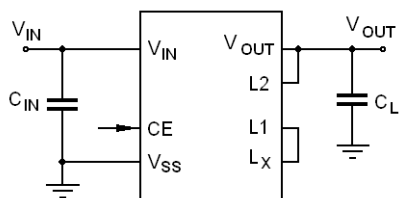

Pins L1 –  $L_X$  and L2 –  $V_{OUT}$  should be connected externally

### TYPICAL PERFORMANCE CHARACTERISTIC

Efficiency vs. Output Current ( $f_{OSC} = 3.0\text{ MHz}$ ,  $V_{OUT} = 3.3\text{ V}$ )

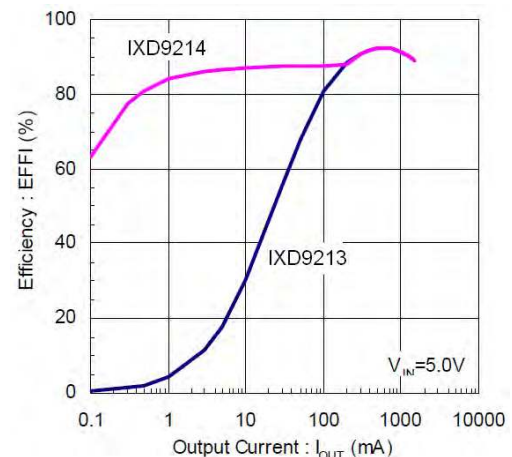

## ABSOLUTE MAXIMUM RATINGS

PARAMETER	SYMBOL	RATINGS	UNITS
V <sub>IN</sub> Pin Voltage	V <sub>IN</sub>	- 0.3 ~ 6.2	V
L <sub>X</sub> Pin Voltage	V <sub>LX</sub>	- 0.3 ~ V <sub>IN</sub> + 0.3 <sup>1)</sup>	V
V <sub>OUT</sub> Pin Voltage	V <sub>OUT</sub>	- 0.3 ~ V <sub>IN</sub> + 0.3 <sup>2)</sup>	V
CE Pin Voltage	V <sub>CE</sub>	- 0.3 ~ 6.2	V
L <sub>X</sub> Pin Current	I <sub>LX</sub>	4500	mA
Inductor Current at ΔT = 40°C	I <sub>LMAX</sub>	1800	mA
Power Dissipation	P <sub>D</sub>	1200	mW
Operating Temperature Range	T <sub>OPR</sub>	- 40 ~ + 85	°C
Storage Temperature Range	T <sub>STG</sub>	- 55 ~ +125	°C

### NOTE:

1. L<sub>X</sub> pin voltage should not exceed V<sub>IN</sub> + 0.3 V or 6.2 V, which is less.
2. V<sub>OUT</sub> pin voltage should not exceed V<sub>IN</sub> + 0.3 V or 4.0 V, which is less.

## ELECTRICAL OPERATING CHARACTERISTICS

IXD9213/14 series, T<sub>a</sub> = 25°C

PARAMETER	SYMBOL	CONDITIONS	MIN.	TYP.	MAX.	UNIT	CIRCUIT
Operating Voltage Range	V <sub>IN</sub>		2.7	-	5.5	V	①
Output Voltage	V <sub>OUT</sub>	V <sub>IN</sub> = V <sub>CE</sub> = 5.0 V, I <sub>OUT</sub> = 30 mA	E-1	E-2	E-3	V	①
Maximum Output Current <sup>1)</sup>	I <sub>OUT_MAX</sub>	V <sub>IN</sub> = V <sub>CE</sub> = C-1 value	1500			mA	①
UVLO Voltage <sup>2)</sup>	V <sub>UVLO</sub>	V <sub>CE</sub> = V <sub>IN</sub> , V <sub>OUT</sub> = 0.6 V	1.35	2.00	2.68	V	③
Supply Current	I <sub>Q</sub>	V <sub>IN</sub> = V <sub>CE</sub> = 5.0 V, V <sub>OUT</sub> = V <sub>OUT(E)</sub> × 1.1 V		400	825	μA	②
				25	40		
Standby Current	I <sub>STB</sub>	V <sub>IN</sub> = 5.0 V, V <sub>CE</sub> = 0 V, V <sub>OUT</sub> = V <sub>OUT(E)</sub> × 1.1 V		0	1.0	μA	②
Minimum On-time	t <sub>ONMIN</sub>	V <sub>CE</sub> = V <sub>IN</sub> = C1	E-4	E-5	E-6	ns	
Thermal Shutdown	T <sub>TSD</sub>			150		°C	
Thermal Shutdown Hysteresis	T <sub>TSDH</sub>			30		°C	
L <sub>X</sub> "H" ON Resistance <sup>3)</sup>	R <sub>LXH</sub>	V <sub>IN</sub> = V <sub>CE</sub> = 5.0 V, V <sub>OUT</sub> = 0.6 V, I <sub>LX</sub> = 100 mA		0.14	0.28	Ω	④
L <sub>X</sub> "L" ON Resistance <sup>4)</sup>	R <sub>LXL</sub>	V <sub>IN</sub> = V <sub>CE</sub> = V <sub>OUT(T)</sub> × 1.1 V, I <sub>LX</sub> = 100 mA		0.10	0.20	Ω	
L <sub>X</sub> "H" Leakage Current	I <sub>LXH</sub>	V <sub>IN</sub> = 5.5 V, V <sub>CE</sub> = V <sub>OUT</sub> = 0 V, V <sub>LX</sub> = 0 V		0.01	1.0	μA	⑤
L <sub>X</sub> "L" Leakage Current	I <sub>LXH</sub>	V <sub>IN</sub> = V <sub>CE</sub> = 5.5 V, V <sub>OUT</sub> = 0 V, V <sub>LX</sub> = 5.5 V		0.01	30	μA	⑤
Current Limit <sup>5)</sup>	I <sub>LIM</sub>	V <sub>OUT</sub> = 0.6 V, I <sub>LX</sub> increases until oscillations starts	2.5	3.0	4.5	A	⑥
Output Voltage Temperature Characteristics	$\frac{\Delta V_{OUT}}{V_{OUT} * \Delta T_{OPR}}$	-40°C ≤ T <sub>OPR</sub> ≤ 85°C, I <sub>OUT</sub> = 30 mA		±100		ppm/°C	①
CE "H" Voltage	V <sub>CEH</sub>	V <sub>OUT</sub> = 0.6 V	0.65		V <sub>IN</sub>	V	③
CE "L" Voltage	V <sub>CEL</sub>	V <sub>OUT</sub> = 0.6 V	0		0.3	V	③
CE "H" Current	I <sub>ENH</sub>	V <sub>IN</sub> = V <sub>CE</sub> = 5.5 V, V <sub>OUT</sub> = 0 V	-0.1		0.1	μA	⑤
CE "L" Current	I <sub>ENL</sub>	V <sub>IN</sub> = 5.5 V, V <sub>CE</sub> = 0 V, V <sub>OUT</sub> = 0 V	-0.1		0.1	μA	⑤
Soft-Start Time	t <sub>SS</sub>		0.10	0.30	0.50	ms	①
Short Protection Threshold Voltage	V <sub>SHORT</sub>	V <sub>OUT</sub> voltage, at which L <sub>X</sub> goes into "L" state <sup>6)</sup>	0.17	0.27	0.37	V	⑦
C <sub>L</sub> Discharge Resistance	R <sub>CLD</sub>	V <sub>CE</sub> = 0, V <sub>OUT</sub> = 4.0 V	50	210	300	Ω	⑧
Inductance Value	L	Test frequency 1 MHz		0.5		μH	
Inductor Current Maximum	I <sub>LMAX</sub>	ΔT = 40°C		1800		mA	

**ELECTRICAL OPERATING CHARACTERISTICS (CONTINUED)**

**NOTE:**

Test conditions: Unless otherwise stated,  $V_{IN} = V_{CE} = 5.0\text{ V}$ ,  $V_{OUT(E)} =$  Nominal Voltage.

- 1) When the difference between the input and the output is so low that duty cycle becomes equal 100%, internal control circuit will keep P-channel transistor in on state, disregard to the output current value. If load current increases further from this state, output voltage will decrease because of P-channel transistor ON resistance.
- 2) Including hysteresis operating voltage range
- 3)  $R_{LXH}$  resistance ( $\Omega$ ) =  $(V_{IN} - Lx \text{ pin measurement voltage}) / 100\text{mA}$
- 4)  $R_{LXL}$  resistance ( $\Omega$ ) =  $Lx \text{ pin measurement voltage}) / 100\text{mA}$ ; Design target for IXD9214
- 5) Current limit denotes the level of an inductor peak current
- 6) "H" =  $V_{IN} \sim V_{IN} - 1.2\text{ V}$ , "L" =  $+0.1\text{ V} \sim -0.1\text{ V}$

**E-TABLES**

NOMINAL OUTPUT VOLTAGE	$V_{OUT}$ , (V)			$t_{ONMIN}$ , ns				NOMINAL OUTPUT VOLTAGE	$V_{OUT}$ , (V)			$t_{ONMIN}$ , ns			
	E-1	E-2	E-3	C-1	E-4	E-5	E-6		E-1	E-2	E-3	C-1	E-4	E-5	E-6
$V_{OUT(T)}$	MIN.	TYP.	MAX.	$V_{IN}$	MIN.	TYP.	MAX.	$V_{OUT(T)}$	MIN.	TYP.	MAX.	$V_{IN}$	MIN.	TYP.	MAX.
0.80	0.784	0.800	0.816	2.70	71	119	166	2.25	2.205	2.250	2.295	3.75	140	200	260
0.85	0.833	0.850	0.867	2.70	72	121	169	2.30	2.254	2.300	2.346	3.83	140	200	260
0.90	0.882	0.900	0.918	2.70	73	122	171	2.35	2.303	2.350	2.397	3.92	140	200	260
0.95	0.931	0.950	0.969	2.70	74	123	172	2.40	2.352	2.400	2.448	4.00	140	200	260
1.00	0.980	1.000	1.020	2.70	86	123	160	2.45	2.401	2.450	2.499	4.08	140	200	260
1.05	1.029	1.050	1.071	2.70	91	130	169	2.50	2.450	2.500	2.550	4.17	140	200	260
1.10	1.078	1.100	1.122	2.70	95	136	177	2.55	2.499	2.550	2.601	4.25	140	200	260
1.15	1.127	1.150	1.173	2.70	99	142	185	2.60	2.548	2.600	2.652	4.33	140	200	260
1.20	1.176	1.200	1.224	2.70	104	148	193	2.65	2.597	2.650	2.703	4.42	140	200	260
1.25	1.225	1.250	1.275	2.70	108	154	201	2.70	2.646	2.700	2.754	4.50	140	200	260
1.30	1.274	1.300	1.326	2.70	112	160	209	2.75	2.695	2.750	2.805	4.58	140	200	260
1.35	1.323	1.350	1.377	2.70	117	167	217	2.80	2.744	2.800	2.856	4.67	140	200	260
1.40	1.372	1.400	1.428	2.70	121	173	225	2.85	2.793	2.850	2.907	4.75	140	200	260
1.45	1.421	1.450	1.479	2.70	125	179	233	2.90	2.842	2.900	2.958	4.83	140	200	260
1.50	1.470	1.500	1.530	2.70	130	185	241	2.95	2.891	2.950	3.009	4.92	140	200	260
1.55	1.519	1.550	1.581	2.70	134	191	249	3.00	2.940	3.000	3.060	5.00	140	200	260
1.60	1.568	1.600	1.632	2.70	138	198	257	3.05	2.989	3.050	3.111	5.08	140	200	260
1.65	1.617	1.650	1.683	2.75	140	200	260	3.10	3.038	3.100	3.162	5.17	140	200	260
1.70	1.666	1.700	1.734	2.83	140	200	260	3.15	3.087	3.150	3.213	5.25	140	200	260
1.75	1.715	1.750	1.785	2.92	140	200	260	3.20	3.136	3.200	3.264	5.33	140	200	260
1.80	1.764	1.800	1.836	3.00	140	200	260	3.25	3.185	3.250	3.315	5.42	140	200	260
1.85	1.813	1.850	1.887	3.08	140	200	260	3.30	3.234	3.300	3.366	5.50	140	200	260
1.90	1.862	1.900	1.938	3.17	140	200	260	3.35	3.283	3.350	3.417	5.50	142	203	264
1.95	1.911	1.950	1.989	3.25	140	200	260	3.40	3.332	3.400	3.468	5.50	144	206	268
2.00	1.960	2.000	2.040	3.33	140	200	260	3.45	3.381	3.450	3.519	5.50	146	209	272
2.05	2.009	2.050	2.091	3.42	140	200	260	3.50	3.430	3.500	3.570	5.50	148	212	276
2.10	2.058	2.100	2.142	3.50	140	200	260	3.55	3.479	3.550	3.621	5.50	151	215	280
2.15	2.107	2.150	2.193	3.58	140	200	260	3.60	3.528	3.600	3.672	5.50	153	218	284
2.20	2.156	2.200	2.244	3.67	140	200	260								

## PIN CONFIGURATION

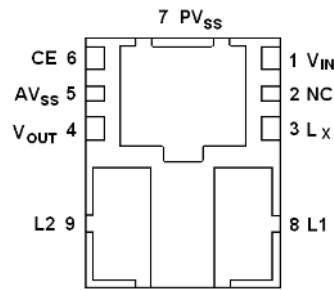

## PIN ASSIGNMENT

PIN NUMBER	PIN NAME	FUNCTIONS
1	V <sub>IN</sub>	Power Input
2	NC	No Connect
3	L <sub>x</sub>	Switching Node
4	V <sub>OUT</sub>	Fixed Output Voltage
5	AV <sub>SS</sub>	Analog Ground
6	CE	Enable (Active HIGH); Do not leave this pin open
7	PV <sub>SS</sub>	Power Ground
8	L1	Inductor Connection
9	L2	Inductor Connection

## BLOCK DIAGRAM

IXD9213/14 Series

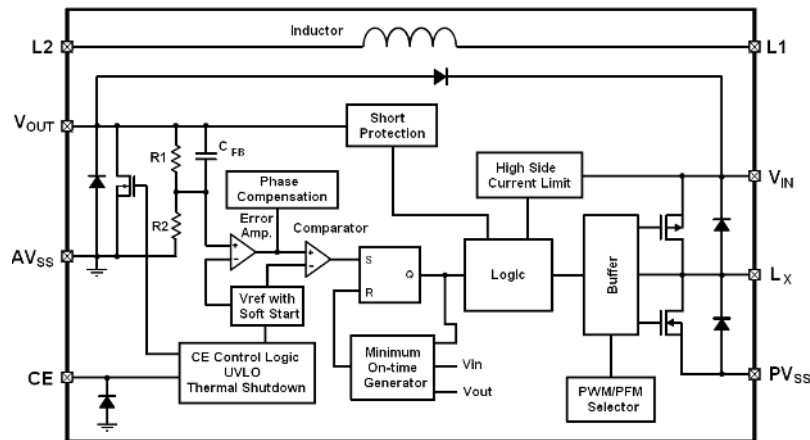

Internal diodes include an ESD protection and a parasitic diode

## BASIC OPERATION

The IXD9213/14 series consists of a Reference Voltage source, Error Amplifier, PWM Comparator, Phase Compensation circuit, minimum on-time generator, output voltage resistive divider, P-channel switching transistor, N-channel transistor for the synchronous switch, Current Limiter circuit, UVLO circuit, and other features. (See the block diagrams above.)

This device operates at a constant on-time mode, which features fast transient response and low output voltage ripple.

The Error Amplifier compares output voltage divided by internal resistors  $R_1/R_2$  with the internal reference voltage. Amplified difference between these two signals applies to the one input of the PWM Comparator, while ramp voltage from minimum on-time generator applies to the second input. The resulting PWM pulse determines switching transistor ON time. It goes through the buffer and it appears at the gate of the internal P-channel switching transistor. This continuous process stabilizes output voltage.

The Current Feedback circuit monitors the current of the P-channel transistor at each switching cycle, and modulates the output signal from the Error Amplifier to provide additional feedback. This guarantees a stable converter operation even with low ESR ceramic load capacitor.

### Reference Voltage Source

The Reference Voltage Source provides the reference voltage to ensure stable output voltage of the DC/DC converter. After the CE pin activates the IC, the reference voltage connected to the error amp increases linearly during the soft-start interval. This allows the output voltage to rise in proportion to the reference voltage. This operation prevents inrush current and allows the output voltage to rise smoothly.

If the output voltage does not reach nominal output voltage within the soft start time due to heavy load or a large output capacitor, the current restriction function activates and prevents an excessive increase of the input current, allowing the output voltage to rise smoothly.

### Minimum On-time Generator

The Minimum On-time Generator produces the signal needed for PWM operation, and signals to synchronize all the internal circuits. The on time is set as a function of the input and output voltages as  $t_{ON} = V_{OUT}/V_{IN} \times 333$  (ns).

### Error Amplifier

The Error Amplifier monitors output voltage through a resistive divider connected to the  $V_{OUT}$  pin. If output voltage falls below the preset value and Error Amplifier's input signal becomes less than internal reference voltage, the Error Amplifier's output signal increases. This results in wider PWM pulse for the switching transistor to increase output voltage. The gain and frequency characteristics of the error amplifier output are fixed internally to optimize IC performance.

### Switching Frequency

The switching frequency is a function of the on time ( $t_{ON}$ ), which is determined by the input voltage and output voltage, as given by the equation below.

$$f_{OSC} (MHz) = V_{OUT} / (V_{IN} \times t_{ON} (ns))$$

### 100% Duty Cycle Mode

When the load current is heavy and the voltage difference between input and output voltage is small, 100% duty cycle mode activates and it keeps the P-channel MOSFET in an on-state. 100% duty cycle mode attains high output voltage stability and high-speed response under all load conditions, from light to heavy, even in conditions where the dropout voltage is low.

### Current Limiter

The Current Limiter circuit monitors current flowing through the P-channel transistor connected to the Lx pin. When the transistor's current is greater than a specified level, the Current Limiter turns off the P-channel transistor immediately. After that, the Current Limiter turns off too, returning to monitoring mode.

The driver transistor turns on at the next cycle, but the Current Limiter turns it off immediately if an over-current exists. When the over current state is eliminated, the IC resumes its normal operation.

### PWM/PFM Selection Circuit

PWM is a continuous conduction mode operation, and utilizes a stable switching frequency determined by the on-time generator.

PWM/PFM auto switching mode allows utilizing a discontinuous conduction mode at light loads, decreasing the switching frequency to reduce switching losses and improve efficiency, while returning to PWM mode and stable frequency at high load.

The IXD9213 series operates in PWM mode only, while the IXD9214 series operates in PWM/PFM auto switching mode.

### UVLO Circuit

When the  $V_{IN}$  pin voltage becomes 2.0 V or lower, the P-channel transistor is forced OFF to prevent false pulse output caused by unstable operation of the internal circuitry. When the  $V_{IN}$  pin voltage becomes 2.10 V or higher, switching operations resume with the soft start. The soft start function operates even when the  $V_{IN}$  voltage falls below the UVLO threshold for a very short time. The UVLO circuit does not cause a complete shutdown of the IC, but causes pulse output to be suspended; therefore, the internal circuitry remains in operation.

### Thermal Shutdown

The thermal shutdown function monitors chip temperature to prevent IC damage. The thermal shutdown circuit starts operating and turns off both P- and N-channel MOSFETs when the chip's temperature reaches 150°C. When the temperature drops to 120°C (typ.) or less, the IC resumes normal operation through soft-start.

### Short-Circuit Protection

Short-circuit protection monitors the output voltage. If output is accidentally shorted to the ground, output voltage starts falling. When this voltage becomes less than the threshold level, Short-Circuit Protection turns off and quickly latches the P-channel transistor.

To restart IC operation after this condition, either the CE pin should be toggled H – L – H, or the V<sub>IN</sub> pin voltage should be set below UVLO to resume operations from soft start.

The sharp load transients creating a voltage drop at the V<sub>OUT</sub> may result in Short Circuit protection operating at voltages higher than the threshold level voltage.

### C<sub>L</sub> High Speed Discharge

The IXD9213/02 B, C, and G series can quickly discharge the output capacitor (C<sub>L</sub>) to avoid application malfunction when the CE pin set logic LOW to disable IC.

C<sub>L</sub> Discharge Time is proportional to the resistance (R) of the N-channel transistor located between the L<sub>x</sub> pin and ground and the output C<sub>L</sub> capacitance as shown below.

$$t_{DSH} = RC_L \times \ln(V_{OUT(E)} / V), \text{ where}$$

V - Output voltage after discharge

V<sub>OUT(E)</sub> - Output voltage

R = 300 Ω (Typical value)

### Output Voltage Discharge Characteristics CE Pin Function

The IXD9213/14 series enters the shut down mode, when a LOW logic-level signal applies to the CE pin. In the

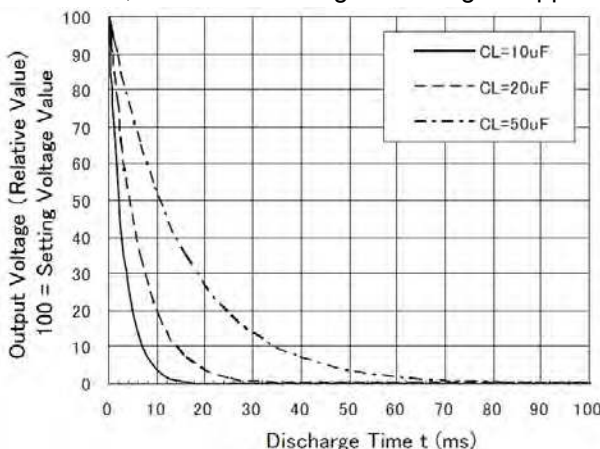

shutdown mode, IC current consumption is ~0.01 μA (Typical value), with the L<sub>x</sub> and V<sub>OUT</sub> pins at high impedance state. The IC starts its operation when a HIGH logic-level signal applies to the CE. The IC does not have pull-up/down resistors at CE input, therefore do not leave this input open to avoid unstable IC operation.

## TYPICAL APPLICATION CIRCUIT

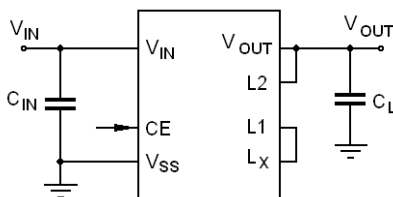

### EXTERNAL COMPONENTS

$C_{IN}$ , $\mu\text{F}$	10
$C_L$ , $\mu\text{F}$	10

Capacitors should be X7R or X5R series to minimize power losses.

### LAYOUT AND USE CONSIDERATIONS

1. Wire external components as close to the IC as possible and use thick, short connecting traces to reduce the circuit impedance. Pay special attention to the  $V_{IN}$  and GND wiring. Switching noise, which occurs from the GND, may cause the instability of the IC; therefore, position the  $V_{IN}$  and  $V_{CL}$  capacitors as close to the IC as possible (See the recommended layout on the right).
2. Use ceramic capacitors of X7R or X5R type to minimize power losses.
3. Transitional voltage drops or voltage rising phenomenon could make the IC unstable, if ratings are exceeded.
4. In PWM mode, switching frequency may vary, depending on input/output voltage, load, external components value, and board layout. In addition, minimum on time generated may differ from calculated value due to IC propagation delay and internal power losses.
5. If the difference between  $V_{IN}$  and  $V_{OUT}$  is small, the IC generates very wide pulses, and there is a possibility that some cycles will be skipped completely at the heavy load current.
6. The inductor's rated current exceeds the Current Limit threshold to avoid damage, which may occur until the P-channel transistor turns off after Current Limiter activates, but pulse current may exceed this value.
7. Use of the IC at voltages below recommended voltage range may lead to instability.
8. In PWM/PFM automatic switching mode, if the difference between input/output voltages is small and load is very low, the inductor current may reverse, thereby decreasing IC efficiency.
9. If the output voltage remains below the short circuit protection threshold voltage at the end of the soft start, IC will stop operation.

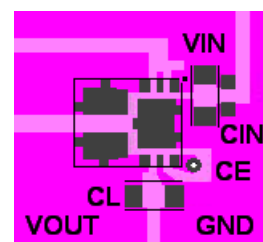



**TEST CIRCUITS**

Circuit ①

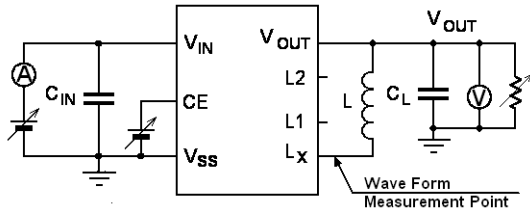

Circuit ②

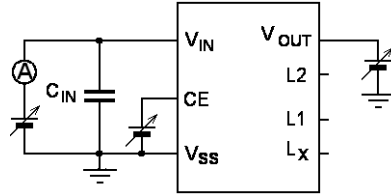

Circuit ③

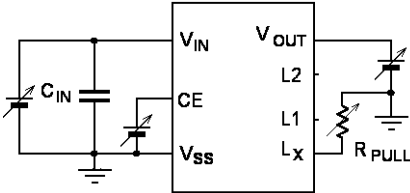

Circuit ④

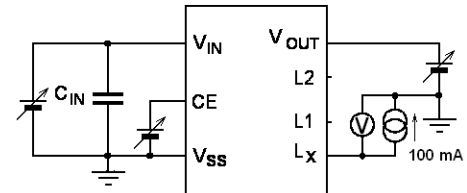

$R_{LXH} = (V_{IN} - V_{OUT})/100 \text{ mA}$ ,  $R_{LXL} = V_{LX}/100 \text{ mA}$

Circuit ⑤

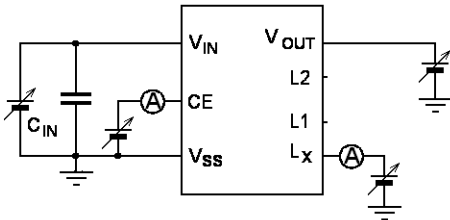

Circuit ⑥

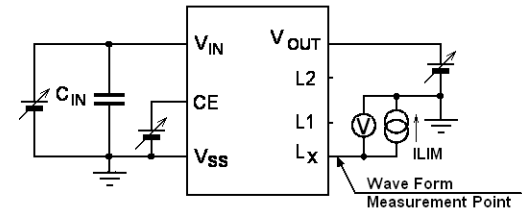

Circuit ⑦

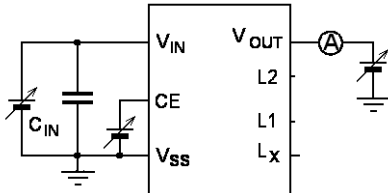

External Components  
 $C_{IN} = 10 \mu\text{F}$  (ceramic),  $C_L = 10 \mu\text{F}$  (ceramic)  
 $L = 1.0 \mu\text{H}$   
 $R_{PULL} = 200 \Omega$



**TYPICAL PERFORMANCE CHARACTERISTICS**

**(1) Output Voltage vs. Output Current**

IXD921xB183DR

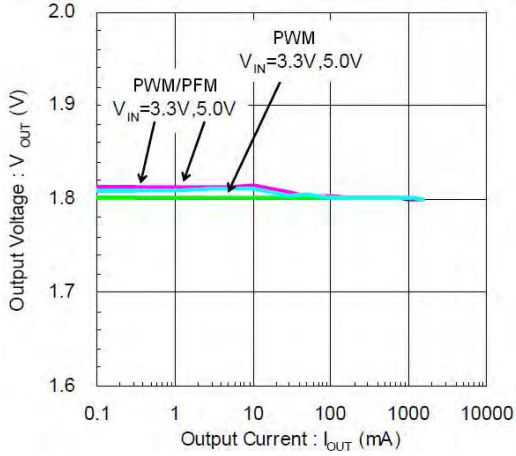

IXD921xB333DR

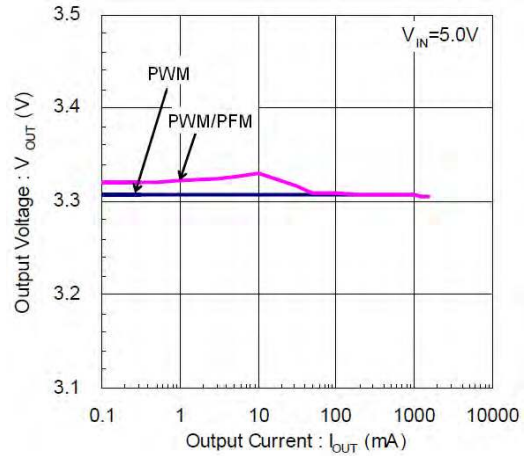

**(2) Efficiency vs. Output Current**

IXD921xB183DR

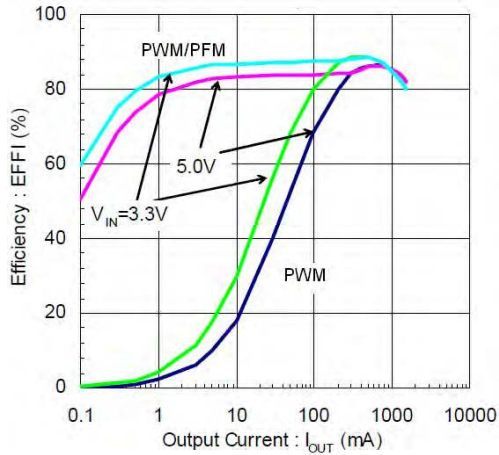

IXD921xB333DR

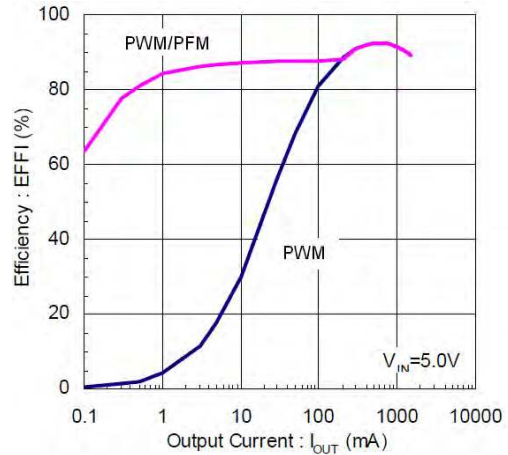

**(3) Ripple Voltage vs. Output Current**

IXD921xB183DR

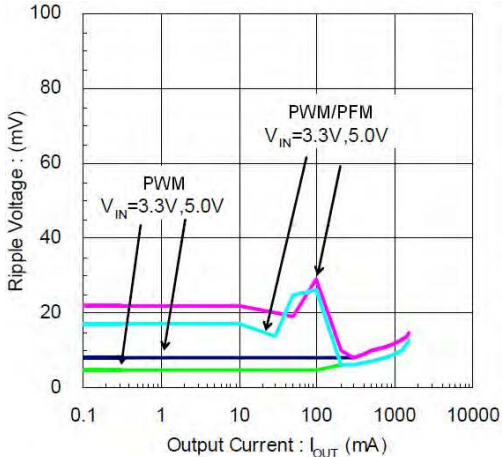

IXD921xB333DR

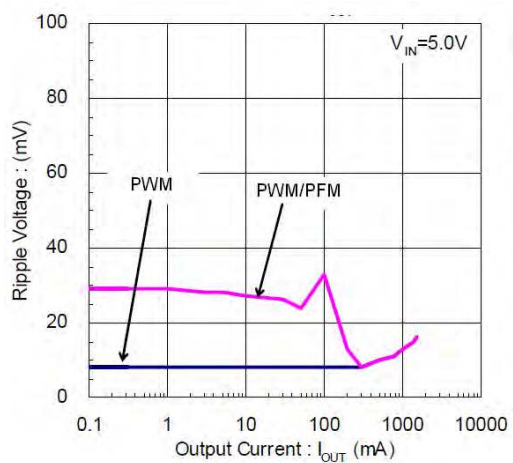

**TYPICAL PERFORMANCE CHARACTERISTICS (Continued)**

**(4) Output Voltage vs. Ambient Temperature**

IXD921xB183DR

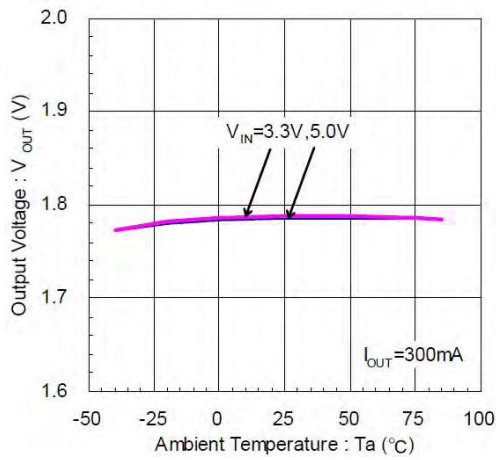

IXD921xB333DR

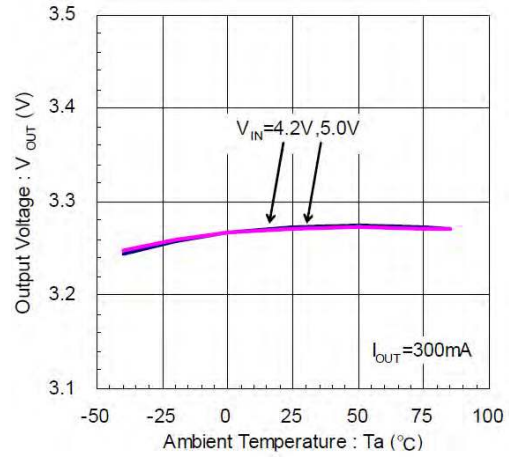

**(5) Oscillation Frequency vs. Temperature**

IXD921xB183DR

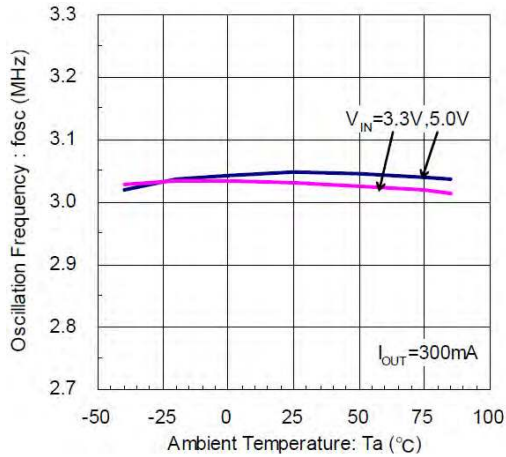

IXD921xB333DR

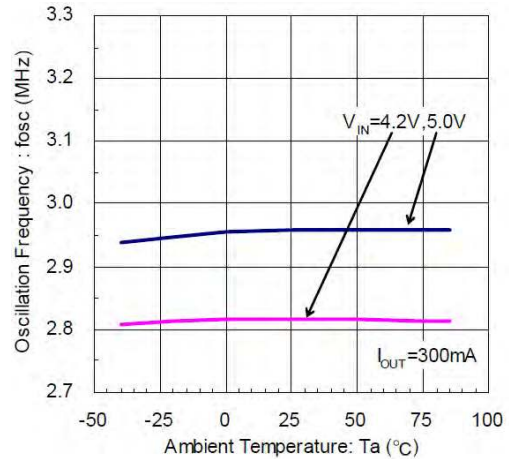

**(6) Oscillation frequency vs. Input Voltage**

IXD921xB183DR

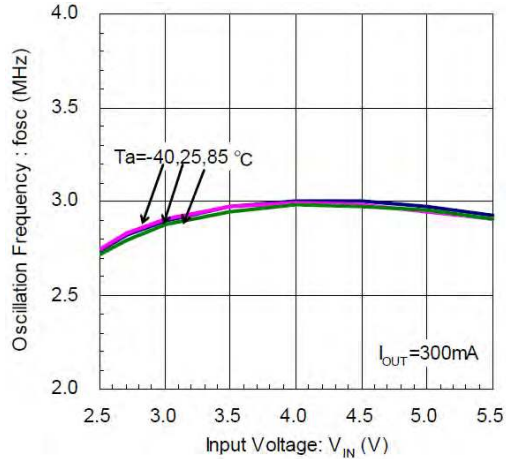

IXD921xB333DR

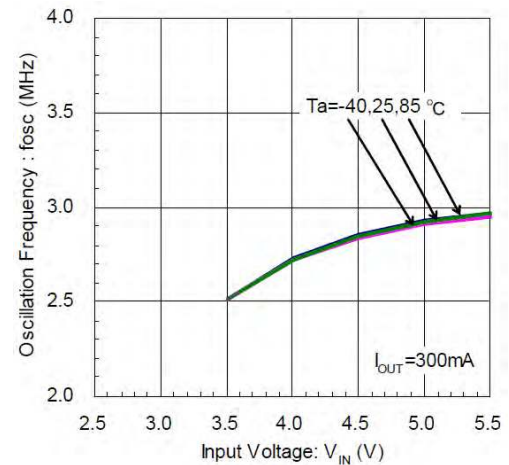

**(7) Load Transient Response**

MODE: PWM/PFM Auto Switching

IXD9214B183DR

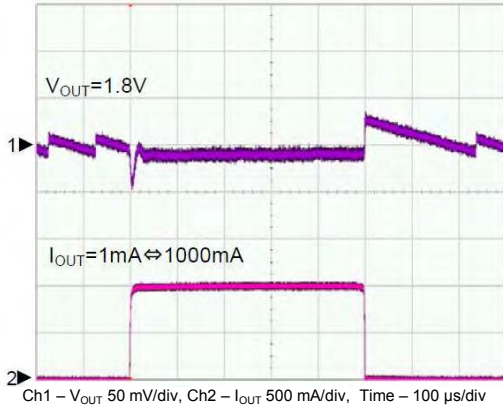

IXD9214B183DR

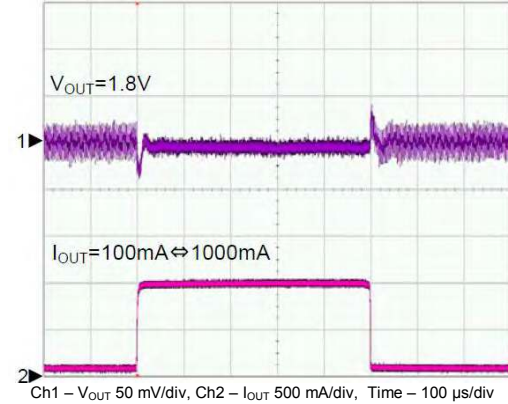

IXD9214B333DR

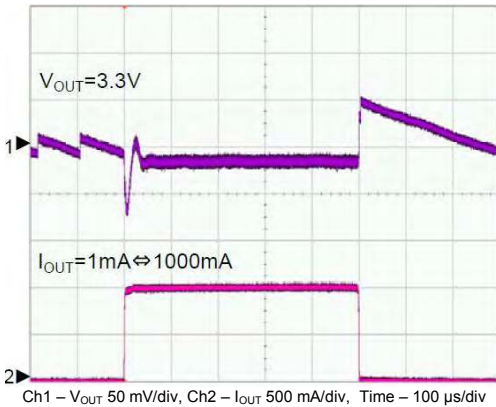

IXD9214B333DR

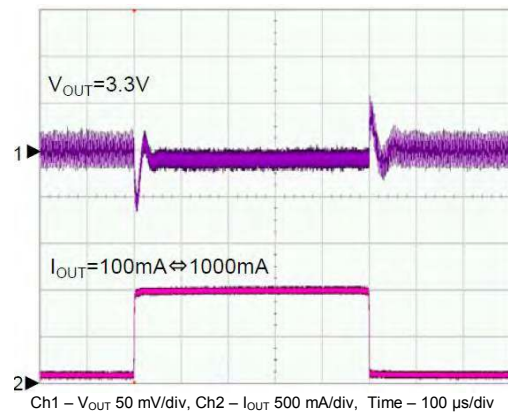

## ORDERING INFORMATION

IXD9213①②③④⑤⑥ PWM Mode only

IXD9214①②③④⑤⑥ PFM/PWM Mode auto switching

DESIGNATOR	DESCRIPTION	SYMBOL	DESCRIPTION
①	Type of DC/DC Controller	B	
②③	Fixed Output Voltage, V	08 - 36	② - Integer part, ③ - decimal part, i.e. V <sub>OUT</sub> = 2.8 V - ② = 2, ③ = 8 For 0.05 V increment designator ③ values are: 0.05 = A, 0.15 = B, 0.25 = C, 0.35 = D, 0.45 = E, 0.55 = F, 0.65 = H, 0.75 = K, 0.85 = L, 0.95 = M V <sub>OUT</sub> = 2,85 V - ② = 2, ③ = L
④	Oscillation Frequency	3	3.0 MHz
⑤⑥ <sup>1)</sup>	Packages (Order Limit)	DR	USP-9B01 (3000/reel)

### NOTE:

- 1) Reels are shipped in a moisture-proof packing.



**MARKING**

USP-9B01

① Represents product series

MARK	PRODUCT SERIES
A	IXD9213Bxx3xx
B	IXD9214Bxx3xx

② Represents integral part of the voltage value

OUTPUT VOLTAGE, V	MARK
	IXD921xBxx3xx
0.x	A
1.x	B
2.x	C
3.x	D

③ Represents decimal part of the Voltage value

V <sub>OUT</sub> , V	MARK
x.00	0
x.05	A
x.10	1
x.15	B
x.20	2
x.25	C
x.30	3
x.35	D
x.40	4
x.45	E
x.50	5
x.55	F
x.60	6
x.65	H
x.70	7
x.75	K
x.80	8
x.85	L
x.90	9
x.95	M

④⑤ Represents production lot number

01~09, 0A~0Z, 11~9Z, A1~A9, AA~AZ, B1~ZZ in order  
(G, I, J, O, Q, and W excluded)

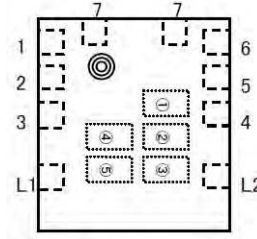

Example for marks ②, ③

V<sub>OUT</sub> = 2.80 V – mark ② = 2, mark ③ = 8

V<sub>OUT</sub> = 2.85 V – mark ② = 2, mark ③ = L

## Customer Support

To share comments, get your technical questions answered, or report issues you may be experiencing with our products, please visit Zilog's Technical Support page at <http://support.zilog.com>. To learn more about this product, find additional documentation, or to discover other facets about Zilog product offerings, please visit the Zilog Knowledge Base at <http://zilog.com/kb> or consider participating in the Zilog Forum at <http://zilog.com/forum>. This publication is subject to replacement by a later edition. To determine whether a later edition exists, please visit the Zilog website at <http://www.zilog.com>.

---

**Warning:** DO NOT USE THIS PRODUCT IN LIFE SUPPORT SYSTEMS.

---

**LIFE SUPPORT POLICY** ZILOG'S PRODUCTS ARE NOT AUTHORIZED FOR USE AS CRITICAL COMPONENTS IN LIFE SUPPORT DEVICES OR SYSTEMS WITHOUT THE EXPRESS PRIOR WRITTEN APPROVAL OF THE PRESIDENT AND GENERAL COUNSEL OF ZILOG CORPORATION.

**As used herein** Life support devices or systems are devices which (a) are intended for surgical implant into the body, or (b) support or sustain life and whose failure to perform when properly used in accordance with instructions for use provided in the labeling can be reasonably expected to result in a significant injury to the user. A critical component is any component in a life support device or system whose failure to perform can be reasonably expected to cause the failure of the life support device or system or to affect its safety or effectiveness.

**Document Disclaimer** ©2015 Zilog, Inc. All rights reserved. Information in this publication concerning the devices, applications, or technology described is intended to suggest possible uses and may be superseded. ZILOG, INC. DOES NOT ASSUME LIABILITY FOR OR PROVIDE A REPRESENTATION OF ACCURACY OF THE INFORMATION, DEVICES, OR TECHNOLOGY DESCRIBED IN THIS DOCUMENT. ZILOG ALSO DOES NOT ASSUME LIABILITY FOR INTELLECTUAL PROPERTY INFRINGEMENT RELATED IN ANY MANNER TO USE OF INFORMATION, DEVICES, OR TECHNOLOGY DESCRIBED HEREIN OR OTHERWISE. The information contained within this document has been verified according to the general principles of electrical and mechanical engineering.