

60 Amp Board-to-Board Power Pin Connectors

IT-P Series

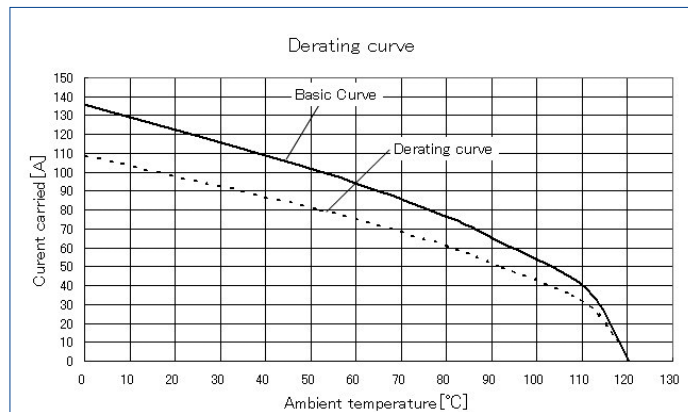

Temperature Rise Curve

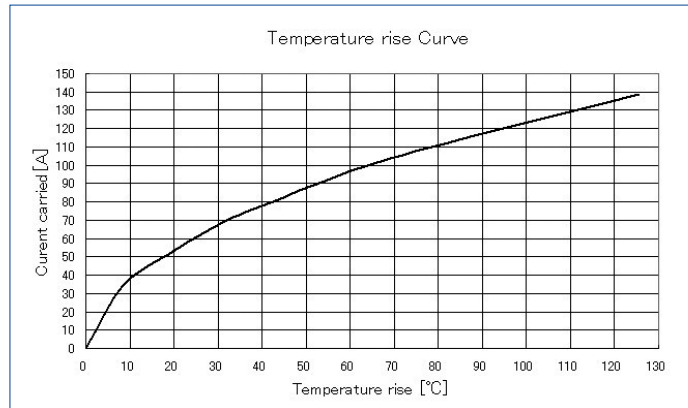

Note : These graphs are for the below combination.
 Interposer : IT-P-2P-35H(11)
 Receptacle : IT-PD-2S-DIR, IT-PM-2S-DIR

Features

1. Up to 60 Amp/pin current rating
2. Unique 3-piece structure for flexibility
3. Multiple mating capability (Floating amount $\pm 0.3\text{mm}$)
4. Paste in hole reflow assembly
5. Stacking heights from 10 to 66mm
6. Designed to be used/assembled alongside IT3, IT5, and IT7

Stacking Height Variations

※All products are designed for +1mm height use, for example IT-P-2P-65H(11) is applicable to 65~66mm height application.

Stacking Height	IT-PB Series		IT-PA Series		IT-P Series																									
	10 mm	11 mm	12 mm	14 mm	15 mm	16 mm	17 mm	21 mm	22 mm	23 mm	24 mm	25 mm	26 mm	27 mm	28 mm	29 mm	30 mm	35 mm	36 mm	37 mm	38 mm	39 mm	40 mm	41 mm	42 mm	43 mm	44 mm	65 mm	66 mm	
	✓	✓	✓	✓	✓	✓	✓	*	*	✓	✓	✓	✓	✓	✓	✓	✓	✓	✓	✓	✓	✓	✓	✓	✓	✓	✓	✓	✓	✓

*Under development / planned

Product Specification

Ratings	Current Rating	60A / pin (Note 6) (Temperature rise 30°C max)	Operating temperature range	-55°C to +85°C (Note 1,2)
	Voltage Rating	300 V DC/AC	Operating humidity range	RH 90% max (Note 2,4)
			Storage temperature range	-10°C to +60°C (Note 3)
			Storage humidity range	RH 70% max (Note 3,4)

Item	Specification	Condition
1. Insulation resistance	1000 MΩ min.	Measured at DC 500V
2. Withstanding voltage	No flashover or insulation breakdown	AC 1000V for 1 minute
3. Contact resistance	2mΩ max (Note 5)	100mA
4. Vibration resistance	No electrical discontinuity of 1μs or more No damage, cracks or loose parts	Frequency : 50 to 2000Hz, Power Spectral Density : 0.1g ² /Hz for 90 minutes in three directions
5. Cyclic temperature and humidity	Contact resistance : 2mΩ max. (Note 5) No damage, cracks or loose parts	25°C, 80% RH : 60 min dwell time, 30 min ramp time 65°C, 50% RH : 60 min dwell time for 24 cycles
6. Durability (Mating / Unmating)	Contact resistance : 2mΩ max. (Note 5) No damage, cracks or loose parts	100 cycles

Note 1 : Include temperature rise caused by current-carrying.

Note 2 : Operating temperature should be -55 to 55°C when humidity exceeds 80% RH.

Note 3 : "Storage" means a long-term storage state for the unused product in sealed packages before assembly to PCB.

Note 4 : No dew condensation is permitted.

Note 5 : The value of contact resistance includes 2 contact points and the bulk resistance.

Note 6 : Current rating of IT-PA and IT-PB series is 40A. (See the details on page 3.)

Materials / Finish

Series	Product	Part	Material	Finish	Remarks
IT-P	Receptacle	Housing (Mounting)	LCP	Black color	UL94V-0
		Housing (Mating)	LCP	Gray color	UL94V-0
		Contact	Copper Alloy	Gold plated	—
	Shell	Brass	Silver plated	—	
Interposer	Housing	PBT	Black color	UL94V-0	
	Contact	Copper Alloy	Silver plated	—	
IT-PA IT-PB	Receptacle	Housing	LCP	Black color	UL94V-0
		Contact	Copper Alloy	Gold plated	—
Shell		Brass	Silver plated	—	
	Interposer	Contact	Copper Alloy	Silver plated	—

Note 1 : The IT-PA and IT-PB series use the same receptacle housing for the mounting and mating sides.

Note 2 : There is no interposer housing for the IT-PA and IT-PB series.

Nomenclature

Please select a product based on the ordering information described on page 3 of this catalog when ordering.

● Receptacle

IT-P ** - 2 S - DIR ** ()**

① ② ③ ④ ⑤ ⑥ ⑦

● Interposer

IT-P ** - 2 P - ** H ** ()**

① ② ③ ④ ⑧ ⑥ ⑦

① Series Name : IT-P	⑥ Packaging or Other Specification ·Receptacle Blank : Standard L : Low height receptacle ** : Customized ·Interposer Blank : Standard ** : Customized
② Extra name Receptacle Type A : Narrow type Receptacle B : Narrow and Low height Receptacle D : Mating Receptacle D* : Mating Receptacle (Customized) M : Mounting Receptacle M* : Mounting Receptacle (Customized) Interposer Type A : Interposer for Narrow type receptacle B : Interposer for Narrow and Low height Receptacle Blank : Standard ** : Customized	⑦ Material and Plating Specification ·Receptacle Blank : Standard ** : Customized ·Interposer Blank : Brass, Contact plating (silver 5.1um + Ni 1.5um) (11) : ETP Copper, Contact plating (silver 5.1um + Ni 1.5um) ** : Customized
③ Contact Positions : 2	⑧ Stacking Height (mm) 10, 11, 14, 16, 21, 23, 25, 27, 29, 35, 37, 39, 41, 43, 65 *All products are designed for +1mm height use, for example IT-P-2P-65H(11) is applicable to 65~66mm height application.
④ Connector type S : Receptacle P : Interposer	
⑤ DIR : Paste in hole (PIH) reflow	

Product Series

IT-P Series

*16H is without housing case, like IT-PA, IT-PB

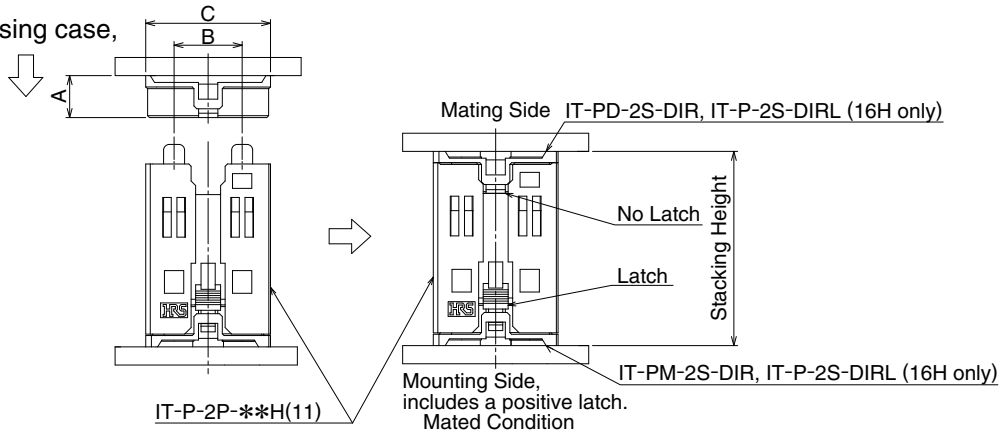

IT-PA Series

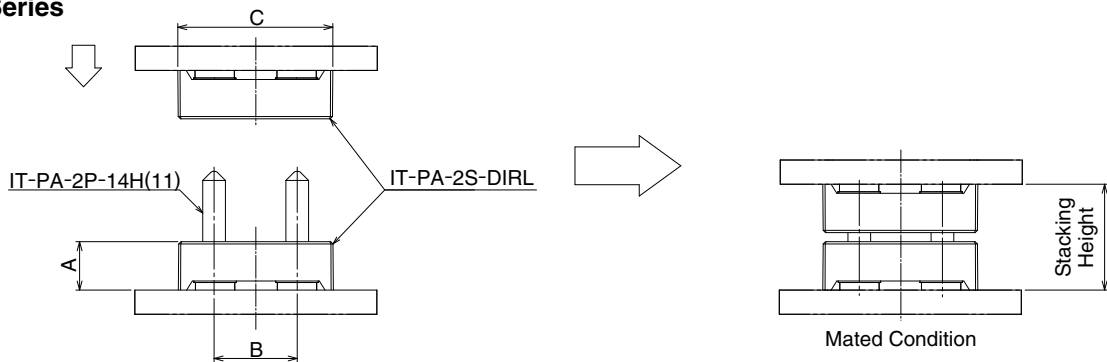

IT-PB Series

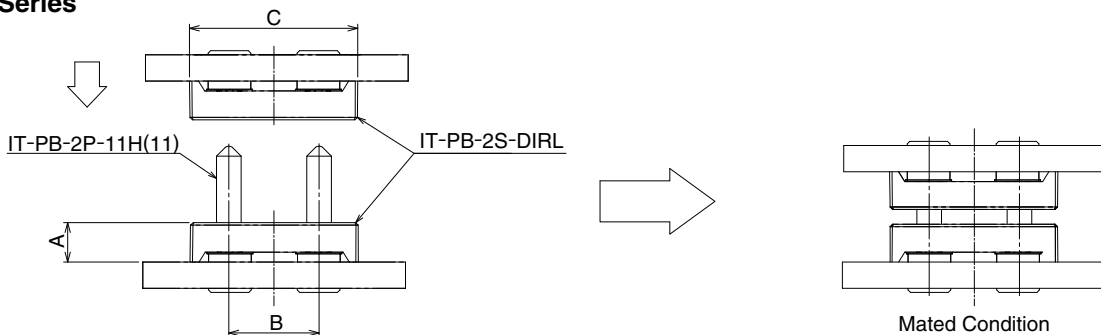

Unit : mm

Stacking Height Range	Current Rating	Interposer		Receptacles		Dimension		
		Part No.	HRS No.	Part No.	HRS No.	A	B	C
10~11	40A	IT-PB-2P-10H(11)	636-0632-0 11	IT-PB-2S-DIRL	636-0631-0	4.65	10.8	20.5
11~12		IT-PB-2P-11H(11)	636-0633-0 11					
14~15		IT-PA-2P-14H(11)	636-0613-9 11					
16~17	60A	IT-P-2P-16H(11)	636-0644-0 11	IT-P-2S-DIRL	636-0611-3	6.6	12	22
21~22		IT-P-2P-21H(11)	636-0618-2 11	IT-PM-2S-DIR IT-PD-2S-DIR	636-0600-7 636-0601-0	7.2	12	22
23~24		IT-P-2P-23H(11)	636-0610-0 11					
25~26		IT-P-2P-25H(11)	636-0607-6 11					
27~28		IT-P-2P-27H(11)	636-0624-5 11					
29~30		IT-P-2P-29H(11)	636-0615-4 11					
35~36		IT-P-2P-35H(11)	636-0602-2 11					
37~38		IT-P-2P-37H(11)	636-0620-4 11					
39~40		IT-P-2P-39H(11)	636-0606-3 11					
41~42		IT-P-2P-41H(11)	636-0619-5 11					
43~44		IT-P-2P-43H(11)	636-0621-7 11					
65~66		IT-P-2P-65H(11)	636-0643-0 11					

Note 1 : IT-PB-2P-10H(**), IT-PB-2P-11H(**), IT-PA-2P-14H(**) and IT-P-2P-16H(**) do not come with a housing.

Note 2 : IT-PA-2P-14H(**) is designed to mate with IT-PA-2S-DIRL only.

Note 3 : IT-PB-2P-10H(**) and IT-PB-2P-11H(**) are designed to mate with IT-PB-2S-DIRL only.

Note 4 : IT-P-2P-16H(**) is designed to mate with IT-P-2S-DIRL only.

IT-P Series
■ Receptacle (Paste in hole)

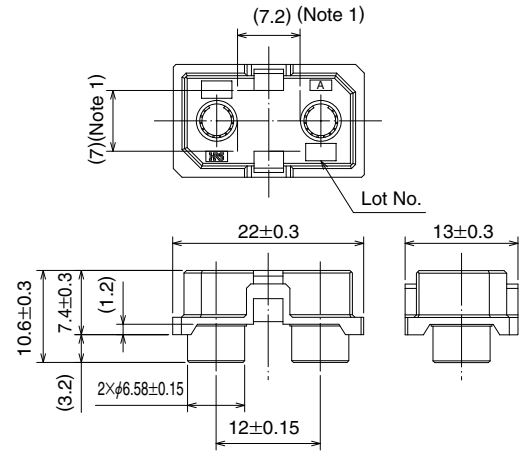
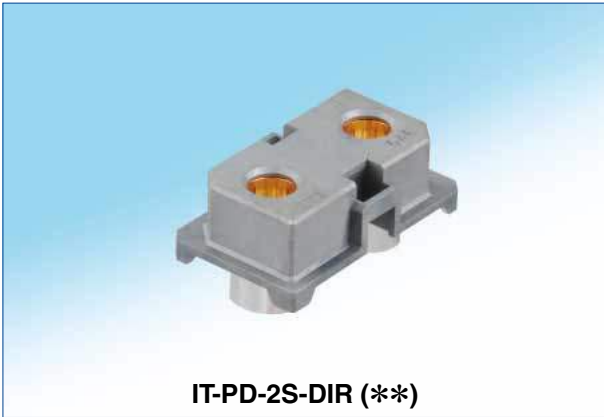

IT-PM-2S-DIR & IT-PD-2S-DIR

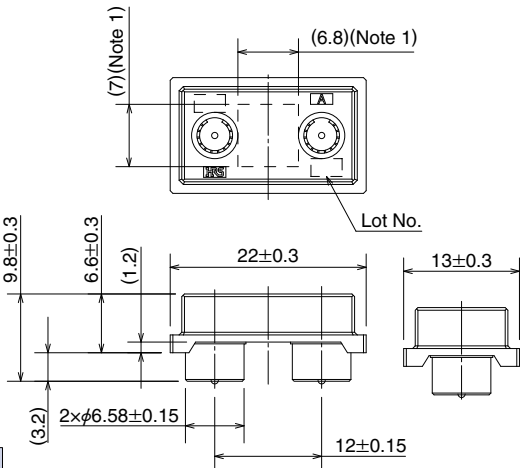

Type	Color	Part No.	HRS No.	No. of contacts	Packing	Pitch
Mating side	Gray	IT-PD-2S-DIR	636-0601-0	2	250pcs/ reel	12mm
Mounting side	Black	IT-PM-2S-DIR	636-0600-7	2		
Mating side	Black	IT-P-2S-DIRL	636-0611-3	2		
Mounting side						

- Note 1 : This area is a vacuum pickup area.
- Note 2 : Minimum clearance area.
- Note 3 : Recommended clearance area for insertion / extraction.
- Note 4 : Please see page 3 (Ordering Information) for applicable Interposers.
- Note 5 : IT-P-2S-DIRL is designed to mate with IT-P-2P-16H(**) only.
- Note 6 : There is no latch for IT-P-2S-DIRL.

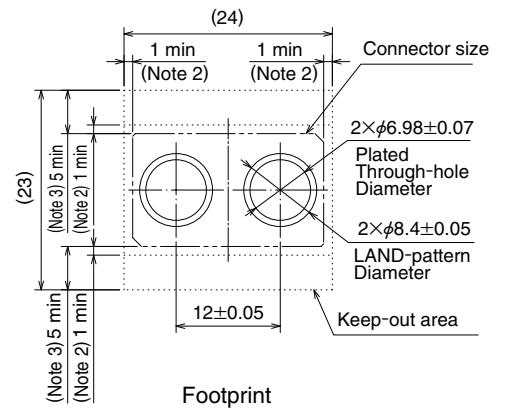

Footprint

IT-PA Series
(Narrow type)
■ Receptacle (Paste in hole)

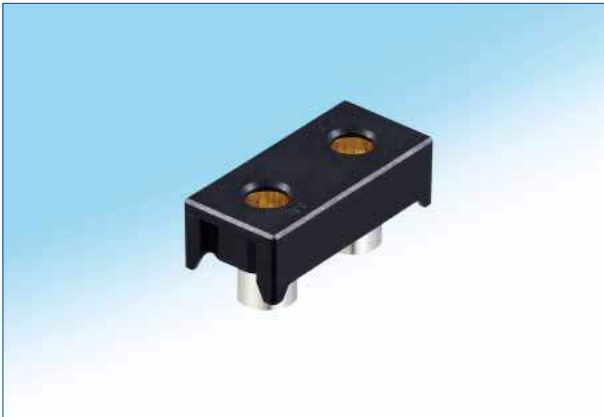

Part No.	HRS No.	No. of contacts	Packing	Pitch
IT-PA-2S-DIRL	636-0614-1	2	250pcs/reel	10.8mm

- Note 1 : This area is a vacuum pickup area.
- Note 2 : Minimum clearance area.
- Note 3 : This product is designed to mate with IT-PA-2P-14H (**) Only.
- Note 4 : IT-PA series are Narrow type of IT-P.
- Note 5 : There is no latch for this receptacle.

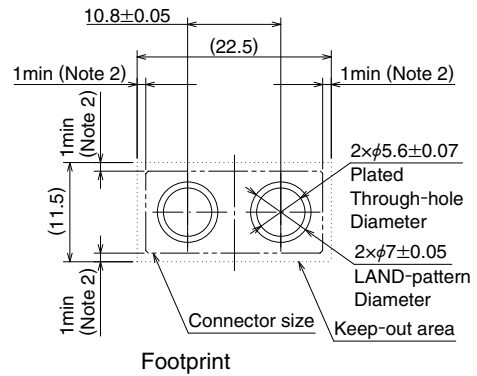
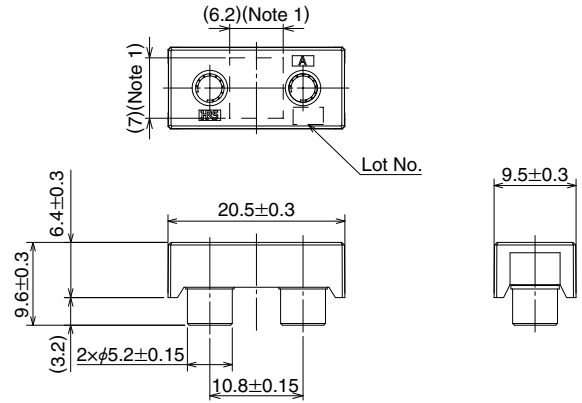

IT-PB Series
(Narrow and Low height type)
■ Receptacle (Paste in hole)



Part No.	HRS No.	No. of contacts	Packing	Pitch
IT-PB-2S-DIRL	636-0631-0	2	250pcs/reel	10.8mm

- Note 1 : This area is a vacuum pickup area.
- Note 2 : Minimum clearance area.
- Note 3 : This product is designed to mate with IT-PB-2P-10H (**) and IT-PB-2P-11H (**) only.
- Note 4 : IT-PB series are Narrow and Low height type of IT-P.
- Note 5 : There is no latch for this receptacle.

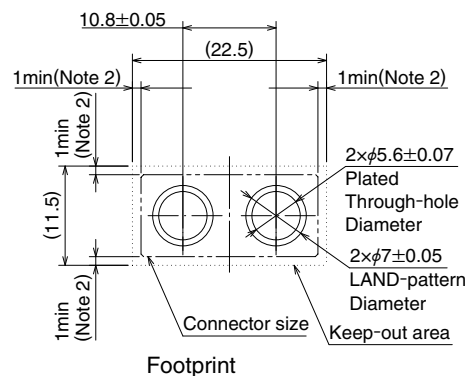
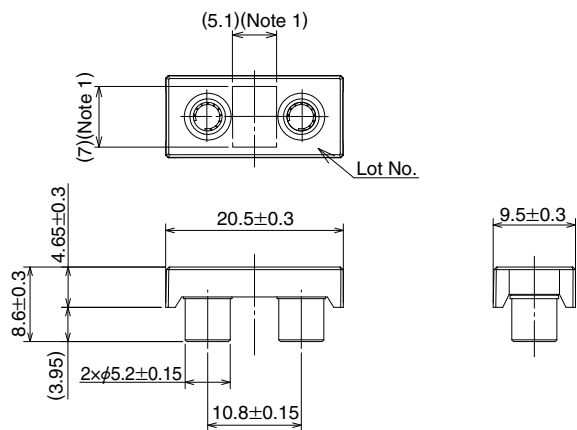

IT-P Series
Interposer with Housing

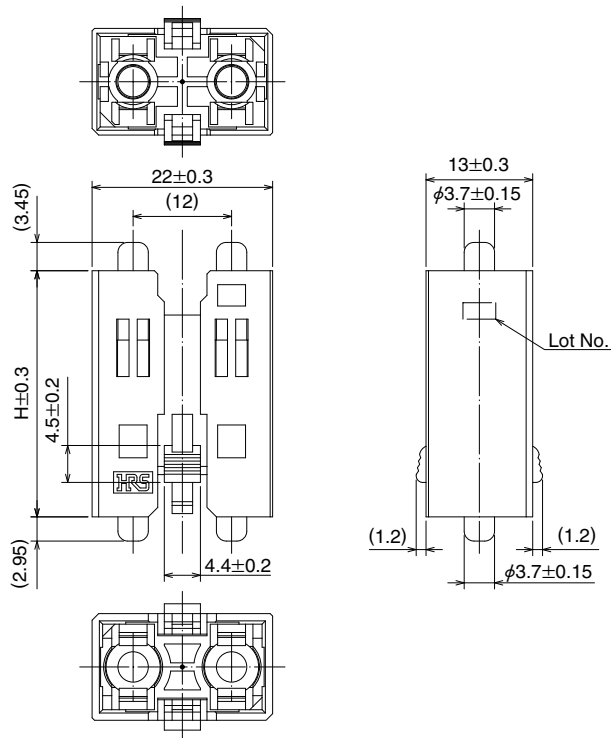

Unit : mm

Part No.	HRS No.	Stacking Height	H	Packing	Pitch
IT-P-2P-21H(11)	636-0618-2 11	21~22	16	50pcs/tray	12
IT-P-2P-23H(11)	636-0610-0 11	23~24	18		
IT-P-2P-25H(11)	636-0607-6 11	25~26	20		
IT-P-2P-27H(11)	636-0624-5 11	27~28	22		
IT-P-2P-29H(11)	636-0615-4 11	29~30	24	56pcs/tray	
IT-P-2P-35H(11)	636-0602-2 11	35~36	30	25pcs/tray	
IT-P-2P-37H(11)	636-0620-4 11	37~38	32	40pcs/tray	
IT-P-2P-39H(11)	636-0606-3 11	39~40	34		
IT-P-2P-41H(11)	636-0619-5 11	41~42	36		
IT-P-2P-43H(11)	636-0621-7 11	43~44	38		
IT-P-2P-65H(11)	636-0643-0 11	65~66	60		28pcs/tray

IT-P, IT-PA, IT-PB Series
Interposer without Housing

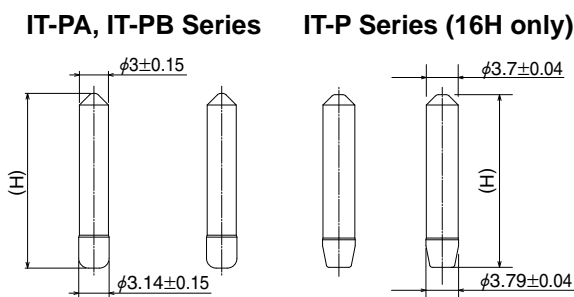

Unit : mm

Part No.	HRS No.	Stacking Height	H	Packing
IT-PB-2P-10H(11)	636-0632-0 11	10~11	16.5	50pairs/tray
IT-PB-2P-11H(11)	636-0633-0 11	11~12	17.5	
IT-PA-2P-14H(11)	636-0613-9 11	14~15	18	
IT-P-2P-16H(11)	636-0644-0 11	16~17	20	

Note 1 : The larger side (φ3.14) or (φ3.79) of the pin should be inserted to mother board side since it has a locking mechanism.

You can remove the pin if you pull strongly.

Note 2 : The thinner side (φ3) or (φ3.7) does not have any locking mechanism.

■ Precautions For Use

1. Recommended Temperature Profile

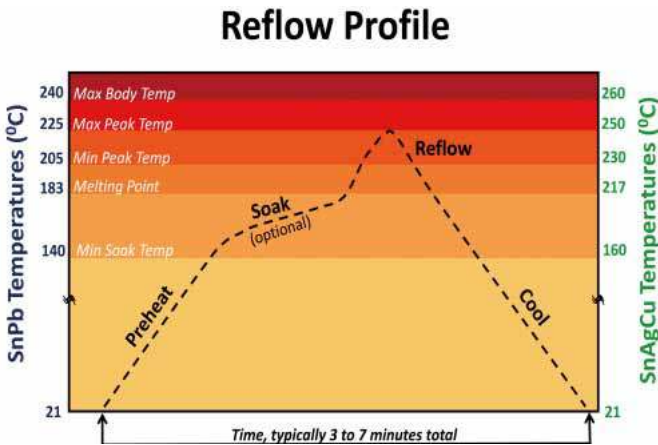

Parameters	Eutectic(SnPb)	Pb-Free	Comment
Preheat Ramp Rate	2 - 3°C/sec	2 - 3°C/sec	Other components may limit ramp rate to 2°C/sec.
Soak Time	0-120 sec	0-120 sec	Soak requirements determined by board design, oven capability, and paste activation requirements
Soak Temperature	140 - 180°C	160 - 215°C	Caution-"oversoaking" may exhaust flux and affect soldering
Peak Reflow Temperature	205 - 225°C	230 - 250°C	Cooler peak temperatures may require longer TAL's
Time Above Liquidus (TAL)	30-90 sec	45 - 120 sec	Shorter TAL's may require higher peak temperatures
Cooling Rate	>6°C/sec	>6°C/sec	Faster cooling rates produce finer grain structures and smoother joint appearances
Maximum Package Body Terminal (T)	240°C	260°C	Open body design allows for low delta T between package and solder joint
Maximum Delta between Body and PWB at Liquidus	10°C	10°C	Standard practice is easy to achieve with open body design.
Package Body Exposure Limit at Maximum Temperature	5 sec	5 sec	Adjust profile if maximum exposure limit is approached or exceeded

Note 1 : Values in this temperature profile are suggested values only.
 Note 2 : IT-P receptacles are not compatible with the double-sided and inverted reflow.

2-1. Recommended Net Solder Paste Volume for IT-P series.

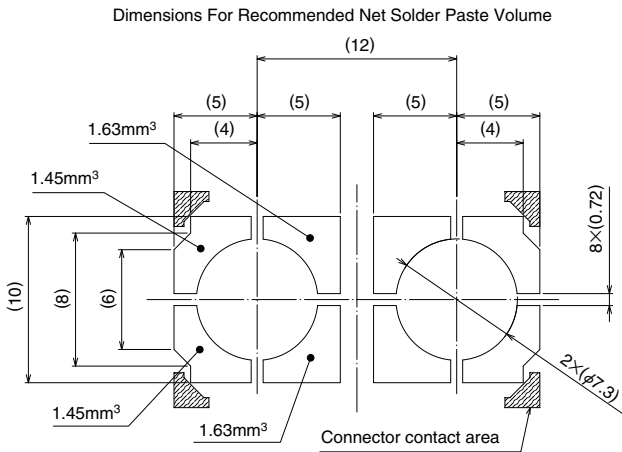

(1) Net solder paste volume : 10.9mm³
 = 12.32mm³ × (100-11.5)%
 <Calculation conditions>
 • Stencil thickness of 0.12mm
 • Flux content of 11.5%

Dimensions For Recommended Solder Preform Placement

Note1. The following solder preform volume shows 2.4mm board thickness.

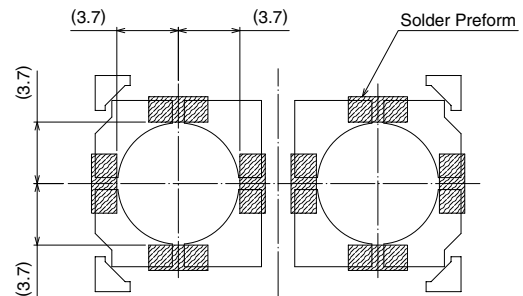

(2) Solder preform volume : 32.768mm³
 <Calculation conditions>
 • Recommended Preform Solder : SMIC Chip Solder S M705
 • Size : 3.2 × 1.6 × 0.8 = 4.096mm³
 • Quantity : 8 pcs

2-2. Recommended Net Solder Paste Volume for IT-PA and IT-PB series.

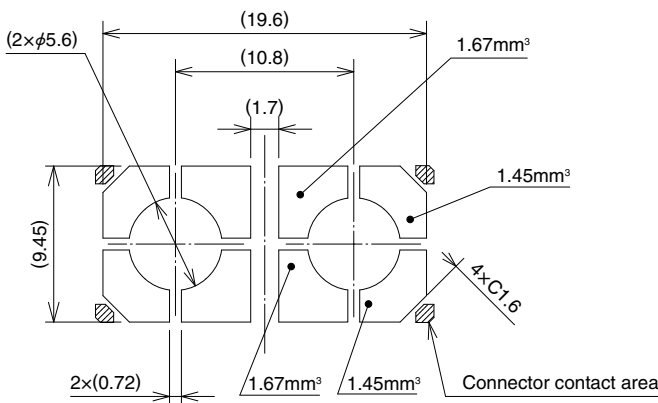

(1) Net solder paste volume : 11.05mm³
 = 12.48mm³ × (100-11.5)%
 <Calculation Conditions>
 • Stencil thickness is 0.12mm
 • Flux content rate is 11.5%

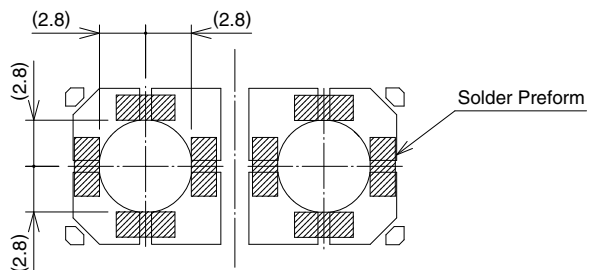

(2) Solder preform volume : 32.768mm³
 <Calculation conditions>
 • Recommended Preform Solder : SMIC Chip Solder S M705
 • Size : 3.2 × 1.6 × 0.8 = 4.096mm³
 • Quantity : 8 pcs

IT-P Series Embossed Carrier Tape Dimensions

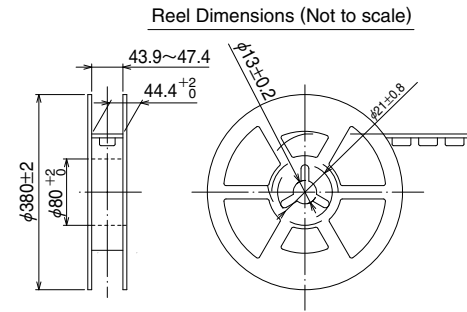
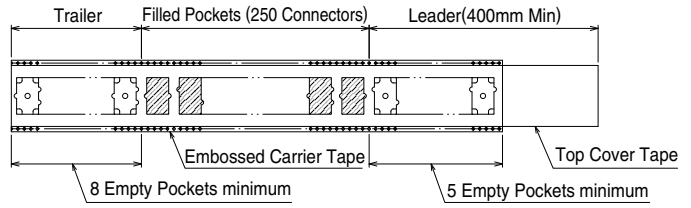
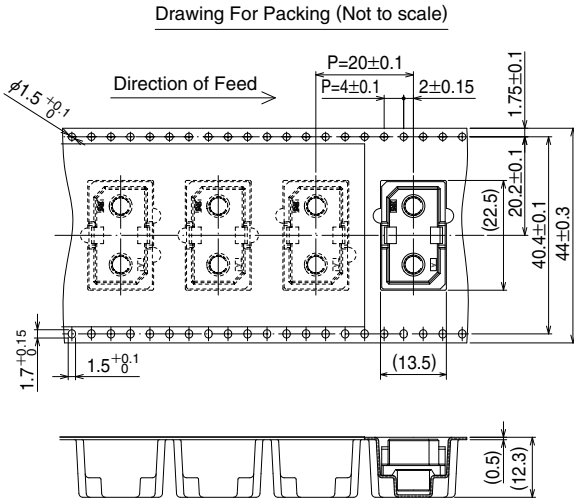

Note : This embossed carrier tape is for IT-PD-2S-DIR, IT-PM-2S-DIR, IT-P-2S-DIRL.

IT-PA and IT-PB Series Embossed Carrier Tape Dimensions

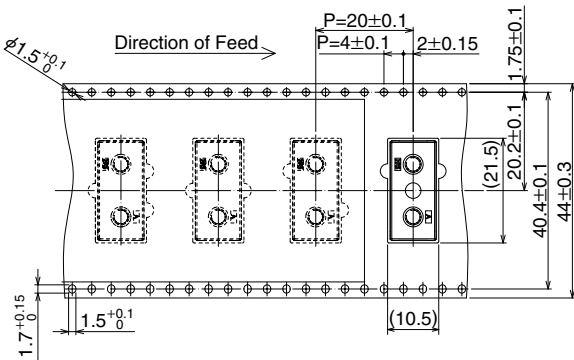

IT-PA Series

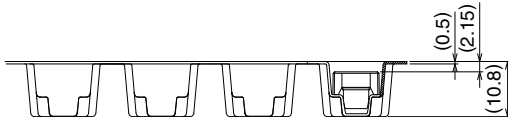

IT-PB Series

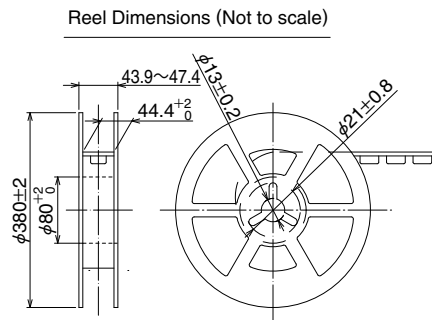
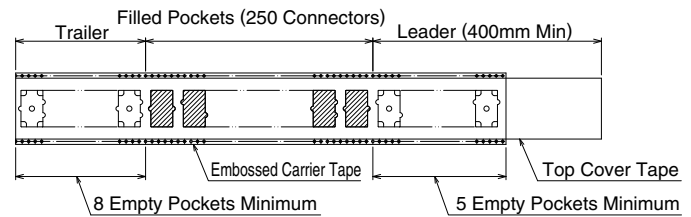

Note : This embossed carrier tape is for IT-PA-2S-DIRL and IT-PB-2S-DIRL.

◆ Dimensions of Interposer Tray

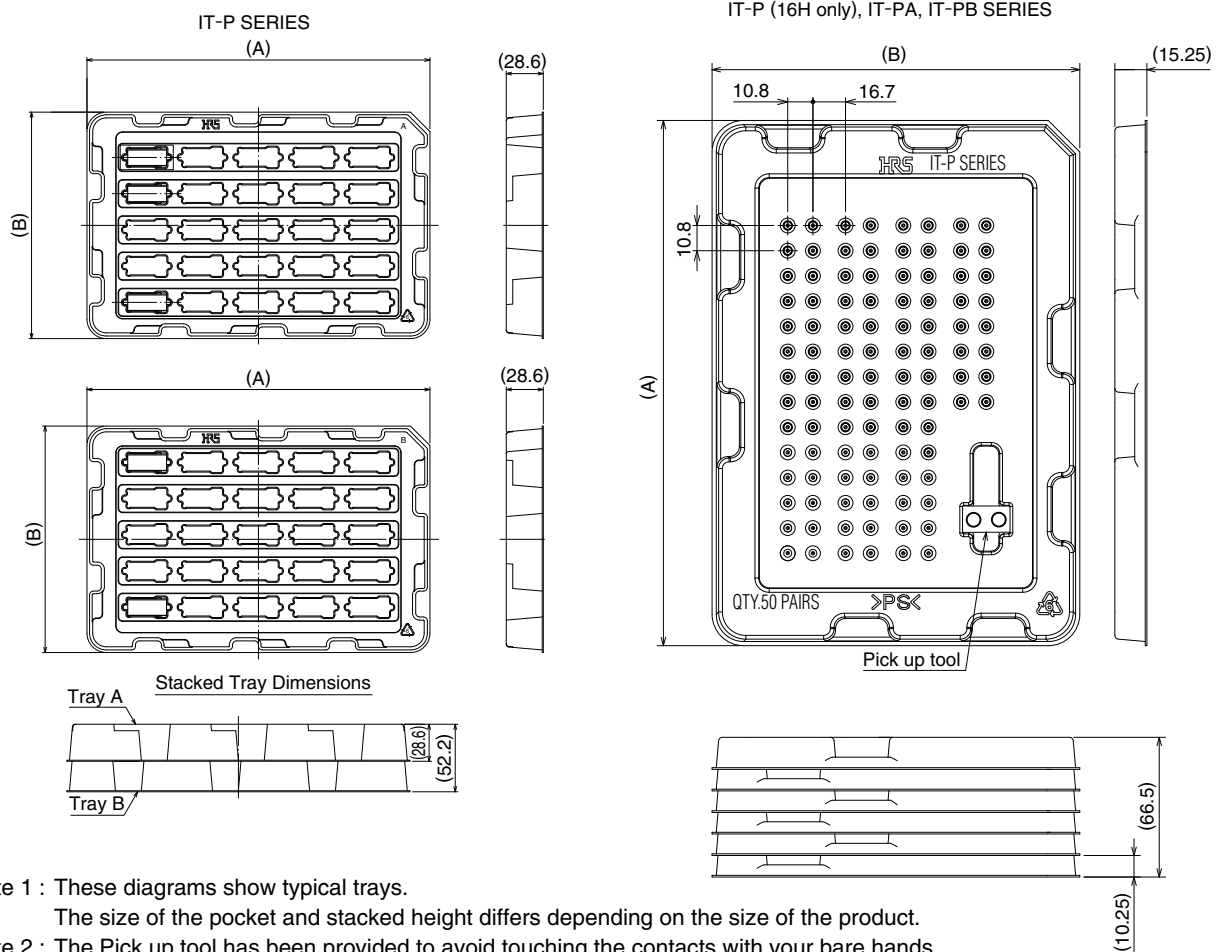

Note 1 : These diagrams show typical trays.

The size of the pocket and stacked height differs depending on the size of the product.

Note 2 : The Pick up tool has been provided to avoid touching the contacts with your bare hands.

Note 3 : The Pick up tool with the red housing should be discarded after use.

Note 4 : The interposer of IT-P-2P-16H (**), IT-PA and IT-PB series are placed into the tray with the larger side down.

◆ Product List

Unit : mm

Part No.	HRS No.	Parts per Tray	Qty per Box	A	B
IT-PB-2P-10H(11)	636-0632-0 11	* 50 pairs	500	250	175
IT-PB-2P-11H(11)	636-0633-0 11				
IT-PA-2P-14H(11)	636-0613-9 11				
IT-P-2P-16H(11)	636-0644-0 11		300		
IT-P-2P-21H(11)	636-0618-2 11	50 pcs	150	355	255
IT-P-2P-23H(11)	636-0610-0 11				
IT-P-2P-25H(11)	636-0607-6 11				
IT-P-2P-27H(11)	636-0624-5 11	56 pcs	112		
IT-P-2P-29H(11)	636-0615-4 11	25 pcs	150	265	175
IT-P-2P-35H(11)	636-0602-2 11				
IT-P-2P-37H(11)	636-0620-4 11	40 pcs	120	355	255
IT-P-2P-39H(11)	636-0606-3 11				
IT-P-2P-41H(11)	636-0619-5 11				
IT-P-2P-43H(11)	636-0621-7 11				
IT-P-2P-65H(11)	636-0643-0 11	28 pcs	56		

*16H is without housing case.

*1 pair = 2 contact pins

Installation

<IT-P Series>

① Solder the Receptacle

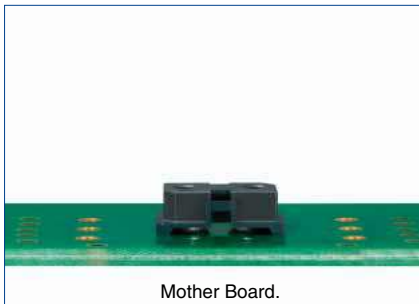

② Install Interposer

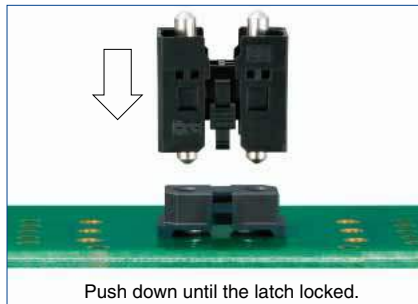

③ Interposer Installed



④ Install Daughter Card



⑤ Mated

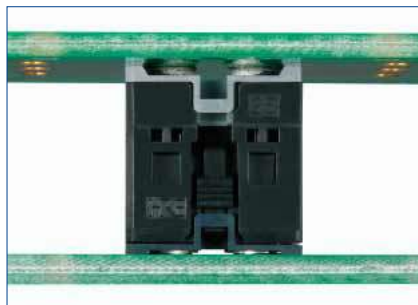

<IT-PA, IT-PB Series>

① Solder the Receptacle



② Pick up the Interposer and install into the receptacle

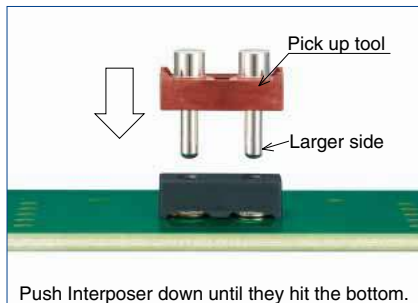

③ Interposer Installed

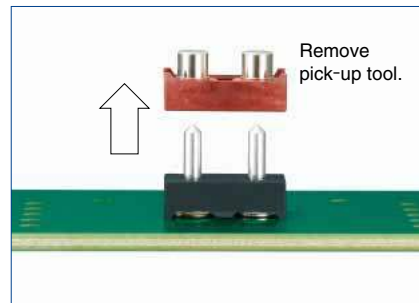

④ Install Daughter Card

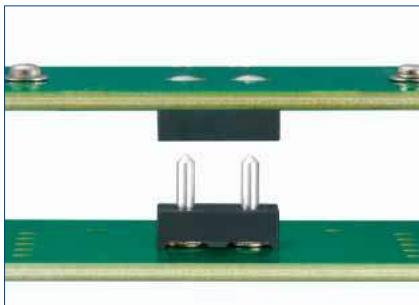

⑤ Mated

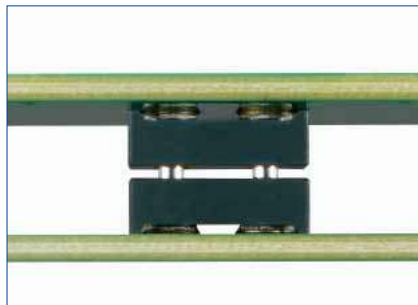

Note 1 : To prevent silver tarnish, do not touch the contacts with your bare hands.

Use the mating receptacle that has been provided as a pick up tool.

Note 2 : The pick up tool is intended to be used to pick up the contacts in tray and then be discarded.

MEMO :

Dotted lines for writing.

USA:

HIROSE ELECTRIC (U.S.A.), INC. HEADQUARTERS CHICAGO OFFICE
2300 Warrenville Road, Suite 150,
Downers Grove, IL 60515
Phone : +1-630-282-6700
<http://www.hirose.com/us/>

USA:

HIROSE ELECTRIC (U.S.A.), INC. BOSTON OFFICE
300 Brickstone Square Suite 201,
Andover, MA 01810
Phone : +1-978-662-5255

GERMANY:

HIROSE ELECTRIC EUROPE B.V. NUREMBERG OFFICE
Neumeyerstrasse 22-26, 90411 Nurnberg
Phone : +49-911 32 68 89 63
Fax : +49-911 32 68 89 69
<http://www.hirose.com/eu/>

UNITED KINGDOM:

HIROSE ELECTRIC EUROPE BV (UK BRANCH)
4 Newton Court, Kelvin Drive, Knowlhill,
Milton Keynes, MK5 8NH
Phone : +44-1908 202050
Fax : +44-1908 202058
<http://www.hirose.com/eu/>

CHINA:

HIROSE ELECTRIC (CHINA) CO., LTD. SHENZHEN BRANCH
Room 09-13, 19/F, Office Tower Shun Hing Square, Di Wang Commercial Centre,
5002 Shen Nan Dong Road, Shenzhen City, Guangdong Province, 518008
Phone : +86-755-8207-0851
Fax : +86-755-8207-0873
<http://www.hirose.com/cn/>

KOREA:

HIROSE KOREA CO.,LTD.
143, Gongdan 1-daero, Siheung-si,
Gyeonggi-do, 15084, Korea
Phone : +82-31-496-7000
Fax : +82-31-496-7100
<http://www.hirose.co.kr/>

INDIA:

HIROSE ELECTRIC SINGAPORE PTE. LTD. BANGALORE LIAISON OFFICE
Unit No-403, 4th Floor, No-84, Barton Centre, Mahatma
Gandhi (MG) Road, Bangalore 560 001, Karnataka, India
Phone : +91-80-4120 1907
Fax : +91-80-4120 9908
<http://www.hirose.com/sg/>

USA:

HIROSE ELECTRIC (U.S.A.), INC. SAN JOSE OFFICE
2841 Junction Ave, Suite 200
San Jose, CA. 95134
Phone : +1-408-253-9640
Fax : +1-408-253-9641
<http://www.hirose.com/us/>

THE NETHERLANDS:

HIROSE ELECTRIC EUROPE B.V.
Hogehillweg #8 1101 CC Amsterdam Z-0
Phone : +31-20-6557460
Fax : +31-20-6557469
<http://www.hirose.com/eu/>

GERMANY:

HIROSE ELECTRIC EUROPE B.V. HANOVER OFFICE
Bayernstr. 3, Haus C 30855 Langenhagen, Germany
Phone : +49-511 97 82 61 30
Fax : +49-511 97 82 61 35
<http://www.hirose.com/eu/>

CHINA:

HIROSE ELECTRIC (CHINA) CO., LTD. (SHANGHAI, HEADQUARTERS)
18, Enterprise Center Tower 2, 209# Gong He
Road, Jing'an District, Shanghai, CHINA 200070
Phone : +86-21-6391-3355
Fax : +86-21-6391-3335
<http://www.hirose.com/cn/>

HONG KONG:

HIROSE ELECTRIC HONGKONG TRADING CO., LTD.
Room 1001, West Wing, Tsim Sha Tsui Centre, 66
Mody Road, Tsim Sha Tsui East, Kowloon, Hong Kong
Phone : +852-2803-5338
Fax : +852-2591-6560
<http://www.hirose.com/hk/>

SINGAPORE:

HIROSE ELECTRIC SINGAPORE PTE. LTD.
03, Anson Road, #20-01, Springleaf Tower,
Singapore 079909
Phone : +65-6324-6113
Fax : +65-6324-6123
<http://www.hirose.com/sg/>

MALAYSIA:

PENANG REPRESENTATIVE OFFICE
73-3-1, Ideal@The One, Jalan Mahsuri, Bayan
Lepas Penang, 11950, Malaysia
Phone : +604-648-5536
<http://www.hirose.com/sg/>

USA:

HIROSE ELECTRIC (U.S.A.), INC. DETROIT OFFICE (AUTOMOTIVE)
17197 N. Laurel Park Drive, Suite 253,
Livonia, MI 48152
Phone : +1-734-542-9963
Fax : +1-734-542-9964
<http://www.hirose.com/us/>

GERMANY:

HIROSE ELECTRIC EUROPE B.V. GERMAN BRANCH
Schoenbergstr. 20, 73760 ostfildern
Phone : +49-711-456002-1
Fax : +49-711-456002-299
<http://www.hirose.com/eu/>

FRANCE:

HIROSE ELECTRIC EUROPE B.V. PARIS OFFICE
130 Avenue Joseph Kessel, Bat E, 78960
Voisins le Bretonneux, France
Phone : +33-1-85764886
Fax : +33-1-85764823
<http://www.hirose.com/eu/>

CHINA:

HIROSE ELECTRIC (CHINA) CO.,LTD. BEIJING BRANCH
A1001, Ocean International Center, Building 56# East 4th
Ring Middle Road, ChaoYang District, Beijing, 100025
Phone : +86-10-5165-9332
Fax : +86-10-5908-1381
<http://www.hirose.com/cn/>

TAIWAN:

HIROSE ELECTRIC TAIWAN CO., LTD.
103 8F, No.87, Zhengzhou Rd., Taipei
Phone : +886-2-2555-7377
Fax : +886-2-2555-7355
<http://www.hirose.com/tw/>

INDIA:

HIROSE ELECTRIC SINGAPORE PTE. LTD. DELHI LIAISON OFFICE
Office NO.552, Regus-Green Boulevard, Level5, Tower C,
Sec62, Plot B-9A, Block B, Noida, 201301, Uttar Pradesh, India
Phone : +91-12-660-8018
Fax : +91-120-4804949
<http://www.hirose.com/sg/>

THAILAND:

BANGKOK OFFICE (REPRESENTATIVE OFFICE)
Unit 4703, 47th FL., 1 Empire Tower, South Sathorn
Road, Yannawa, Sathorn, Bangkok 10120 Thailand
Phone : +66-2-686-1255
Fax : +66-2-686-3433
<http://www.hirose.com/sg/>

**HIROSE ELECTRIC CO.,LTD.**

2-6-3,Nakagawa Chuoh,Tsuzuki-Ku,Yokohama-Shi 224-8540,JAPAN
TEL: +81-45-620-3526 Fax: +81-45-591-3726
<http://www.hirose.com>
<http://www.hirose-connectors.com>