

Dc mind Brush motor

Data sheet

89 810 007

Series

89 810

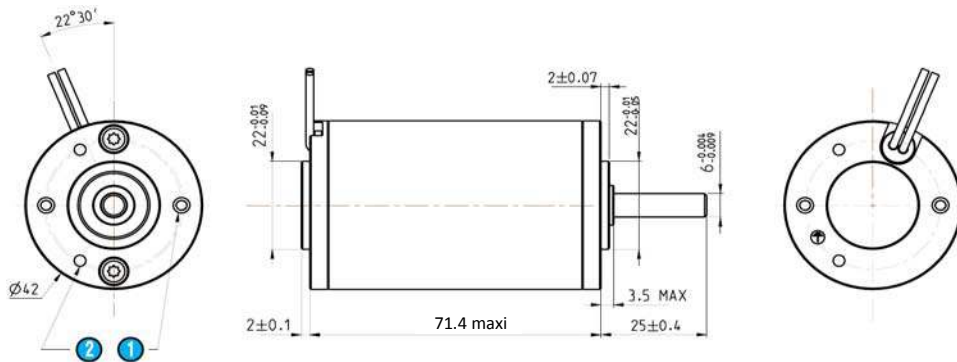

1 2 x M3 at 180°, depth 5 mm and 32mm diameter

2 2 x holes of 2,75 mm diameter, at 120°, depth 5 mm and 32mm diameter

General characteristics

Motor characteristics at (1)		12 Vdc	
At no load - A			
Speed	rpm	4 200	+10%
Current	A	0,26	
Life (2)	h	10 000	
At max efficiency - B			
Speed	rpm	3 500	+10%
Torque (4)	mNm	27	
Power output	W	10	
Current	A	1,26	
Efficiency	%	65	
Life (2)	h	5 000	
At nominal load - C			
Speed	rpm	2 900	+10%
Torque (4)	mNm	50	
Power output	W	15	
Current	A	2,1	
Efficiency	%	60	
Life (2)	h	4 000	
Others			
Starting torque	mNm	158	
Starting current	A	6,1	
Max. output power	W	17	

Motor parameters (1)		
Allowed speed	rpm	10 000 max
Rated torque	mNm	50
Electrical time constant	ms	0,7
Mechanical time constant	ms	20
Factor torque / speed	mNm/rpm	0,03846
Dry friction	mNm	2,5
Viscous friction	mNm/krpm	1
Rotor inertia	gcm ²	75
Thermal Resistance	°W	10
Stator poles		2
Collector blades		8
Cogging torque	mNm	3
Weight (g)	g	340
Noise level	dBA	35

Winding parameters (1)			
Torque constant	mNm/A	27	+10%
Constant electromotive force	Volts/(rad/s)	0,027	+10%
Resistance	V / Krpm	2,85	+10%
Inductance	Ohms	2,0	+10%
Start voltage	mH	1,3	
Current demagnetization	Volts	0,6	
	(magnets at 150 ° C)	A	29

Generic parameters			
Motor for direct current supply			✓
Output shaft with ball bearings			✓
Max. Radial force (20mm from front face)	N		100
Max. axial force(5)	N		70
Temperature range	CEI60068-2-1/2	°C	-30 / 70
Storage temperature		°C	-40 / 100
Dielectric (1min 2mA 50Hz)	CEI60335	Vdc	500
Motor insulation	CEI60085	class	E (120°C)
Enameled wire insulation		class	F (155°C)
Salt spray	CEI60068-2-58	severity	2
Degree of protection	CEI60529	IP	65
EMC			
Electrostatic Discharge	CEI61000-4-2	level	3
Electrical fast transient / burst test	CEI61000-4-4	level	3
Surge test	CEI61000-4-5	level	2
Radiated emission		class	B
Approvals			
Designed in accordance with UL			1004
ROHS	2002/95/CE		✓
EC			✓
Designed for medical machines using the standard			EN60601-1

Values without tolerances, are average production values.

(1) Cold motor, 20 ° C ambient temperature

(2) Continuous cycle, one direction

(3) Continuously rated torque, zero radial and axial loads

(4) Max torque for continuous operation at 20 ° C, decrease this value for higher ambient temperature

(5) Pinion or pulley fitting are done at the Crouzet factory, before final assembly.

Curves

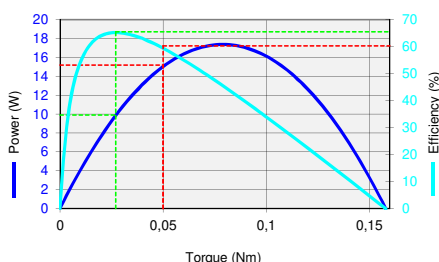
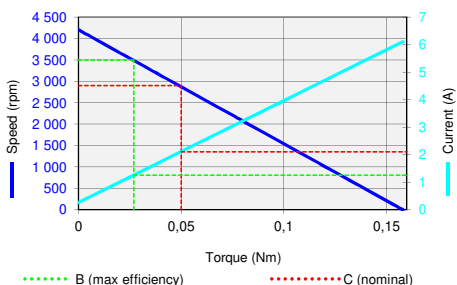

Performance / Motor curves (1)					
Voltage supply		Vdc	12		
Current (mA)					
		A	B	C	D
Speed	rpm	4 200	3 500	2 900	0
Torque (4)	mNm	0	27	50	158
Current	A	0,3	1,3	2,1	6,1
Power output	W	-	10	15	-
Efficiency	%	-	65	60	-