



Is Now Part of



ON Semiconductor®

To learn more about ON Semiconductor, please visit our website at
www.onsemi.com

Please note: As part of the Fairchild Semiconductor integration, some of the Fairchild orderable part numbers will need to change in order to meet ON Semiconductor's system requirements. Since the ON Semiconductor product management systems do not have the ability to manage part nomenclature that utilizes an underscore (_), the underscore (_) in the Fairchild part numbers will be changed to a dash (-). This document may contain device numbers with an underscore (_). Please check the ON Semiconductor website to verify the updated device numbers. The most current and up-to-date ordering information can be found at www.onsemi.com. Please email any questions regarding the system integration to Fairchild_questions@onsemi.com.

ON Semiconductor and the ON Semiconductor logo are trademarks of Semiconductor Components Industries, LLC dba ON Semiconductor or its subsidiaries in the United States and/or other countries. ON Semiconductor owns the rights to a number of patents, trademarks, copyrights, trade secrets, and other intellectual property. A listing of ON Semiconductor's product/patent coverage may be accessed at www.onsemi.com/site/pdf/Patent-Marking.pdf. ON Semiconductor reserves the right to make changes without further notice to any products herein. ON Semiconductor makes no warranty, representation or guarantee regarding the suitability of its products for any particular purpose, nor does ON Semiconductor assume any liability arising out of the application or use of any product or circuit, and specifically disclaims any and all liability, including without limitation special, consequential or incidental damages. Buyer is responsible for its products and applications using ON Semiconductor products, including compliance with all laws, regulations and safety requirements or standards, regardless of any support or applications information provided by ON Semiconductor. "Typical" parameters which may be provided in ON Semiconductor data sheets and/or specifications can and do vary in different applications and actual performance may vary over time. All operating parameters, including "Typicals" must be validated for each customer application by customer's technical experts. ON Semiconductor does not convey any license under its patent rights nor the rights of others. ON Semiconductor products are not designed, intended, or authorized for use as a critical component in life support systems or any FDA Class 3 medical devices or medical devices with a same or similar classification in a foreign jurisdiction or any devices intended for implantation in the human body. Should Buyer purchase or use ON Semiconductor products for any such unintended or unauthorized application, Buyer shall indemnify and hold ON Semiconductor and its officers, employees, subsidiaries, affiliates, and distributors harmless against all claims, costs, damages, and expenses, and reasonable attorney fees arising out of, directly or indirectly, any claim of personal injury or death associated with such unintended or unauthorized use, even if such claim alleges that ON Semiconductor was negligent regarding the design or manufacture of the part. ON Semiconductor is an Equal Opportunity/Affirmative Action Employer. This literature is subject to all applicable copyright laws and is not for resale in any manner.



Single-Channel: 6N138, 6N139 Dual-Channel: HCPL2730, HCPL2731 Low Input Current High Gain Split Darlington Optocouplers

Features

- Low current – 0.5mA
- Superior CTR-2000%
- Superior CMR-10kV/ μ s
- CTR guaranteed 0–70°C
- U.L. recognized (File # E90700)
- VDE recognized (File # 120915) Ordering option V, e.g., 6N138V
- Dual Channel – HCPL2730, HCPL2731

Applications

- Digital logic ground isolation
- Telephone ring detector
- EIA-RS-232C line receiver
- High common mode noise line receiver
- μ P bus isolation
- Current loop receiver

Description

The 6N138/9 and HCPL2730/HCPL2731 optocouplers consist of an AlGaAs LED optically coupled to a high gain split darlington photodetector.

The split darlington configuration separating the input photodiode and the first stage gain from the output transistor permits lower output saturation voltage and higher speed operation than possible with conventional darlington phototransistor optocoupler. In the dual channel devices, HCPL2730/HCPL2731, an integrated emitter-base resistor provides superior stability over temperature.

The combination of a very low input current of 0.5mA and a high current transfer ratio of 2000% makes this family particularly useful for input interface to MOS, CMOS, LSTTL and EIA RS232C, while output compatibility is ensured to CMOS as well as high fan-out TTL requirements. An internal noise shield provides exceptional common mode rejection of 10 kV/ μ s.

Schematic

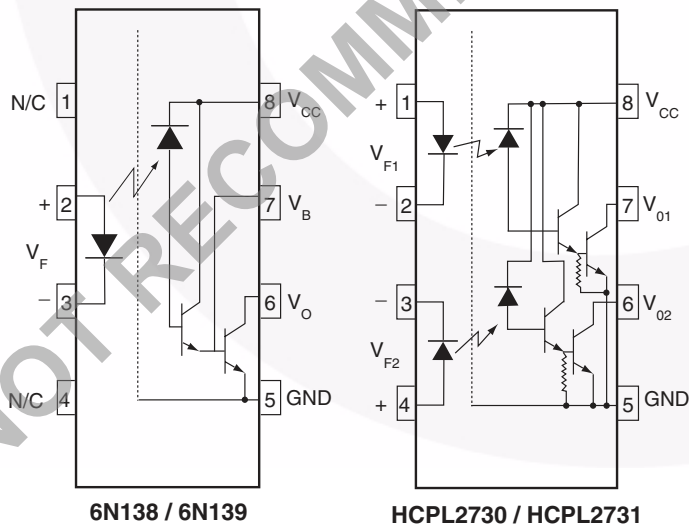

Package Outlines

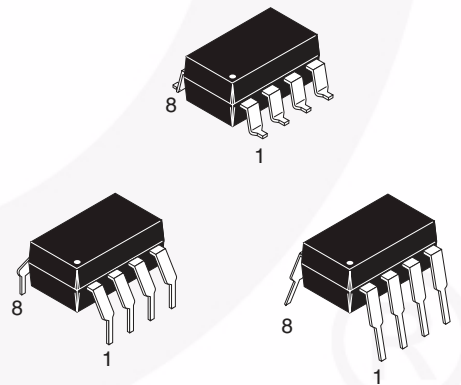

Absolute Maximum Ratings ($T_A = 25^\circ\text{C}$ unless otherwise specified)

Stresses exceeding the absolute maximum ratings may damage the device. The device may not function or be operable above the recommended operating conditions and stressing the parts to these levels is not recommended. In addition, extended exposure to stresses above the recommended operating conditions may affect device reliability. The absolute maximum ratings are stress ratings only.

Symbol	Parameter		Value	Units
T_{STG}	Storage Temperature		-55 to +125	$^\circ\text{C}$
T_{OPR}	Operating Temperature		-40 to +85	$^\circ\text{C}$
T_{SOL}	Lead Solder Temperature (Wave solder only. See recommended reflow profile graph for SMD mounting)		260 for 10 sec	$^\circ\text{C}$
EMITTER				
I_F (avg)	DC/Average Forward Input Current	Each Channel	20	mA
I_F (pk)	Peak Forward Input Current (50% duty cycle, 1 ms P.W.)	Each Channel	40	mA
I_F (trans)	Peak Transient Input Current - ($\leq 1\mu\text{s}$ P.W., 300 pps)		1.0	A
V_R	Reverse Input Voltage	Each Channel	5	V
P_D	Input Power Dissipation	Each Channel	35	mW
DETECTOR				
I_O (avg)	Average Output Current	Each Channel	60	mA
V_{ER}	Emitter-Base Reverse Voltage	6N138 and 6N139	0.5	V
V_{CC}, V_O	Supply Voltage, Output Voltage	6N138, HCPL2730	-0.5 to 7	V
		6N139, HCPL2731	-0.5 to 18	
P_O	Output Power Dissipation	Each Channel	100	mW

Electrical Characteristics ($T_A = 0$ to 70°C unless otherwise specified)**Individual Component Characteristics**

Symbol	Parameter	Test Conditions	Device	Min.	Typ.*	Max.	Unit
EMITTER							
V_F	Input Forward Voltage	$T_A = 25^\circ\text{C}$ Each channel ($I_F = 1.6\text{mA}$)	All		1.30	1.7	V
BV_R	Input Reverse Breakdown Voltage	$T_A = 25^\circ\text{C}$, $I_R = 10\mu\text{A}$	All	5.0	20		V
$\Delta V_F / \Delta T_A$	Temperature Coefficient of Forward Voltage	$I_F = 1.6\text{mA}$	All		-1.8		mV/ $^\circ\text{C}$
DETECTOR							
I_{OH}	Logic HIGH Output Current	$I_F = 0\text{mA}$, $V_O = V_{CC} = 18\text{V}$ Each Channel	6N139 HCPL2731		0.01	100	μA
		$I_F = 0\text{mA}$, $V_O = V_{CC} = 7\text{V}$ Each Channel	6N138 HCPL2730		0.01	250	
I_{CCL}	Logic LOW supply	$I_F = 1.6\text{mA}$, $V_O = \text{Open}$, $V_{CC} = 18\text{V}$ $I_{F1} = I_{F2} = 1.6\text{mA}$, $V_{CC} = 18\text{V}$ $V_{O1} - V_{O2} = \text{Open}$, $V_{CC} = 7\text{V}$	6N138, 6N139 HCPL2731 HCPL2730		0.4	1.5	3 mA
I_{CCH}	Logic HIGH Supply	$I_F = 0\text{mA}$, $V_O = \text{Open}$, $V_{CC} = 18\text{V}$ $I_{F1} = I_{F2} = 0\text{mA}$, $V_{CC} = 18\text{V}$ $V_{O1} - V_{O2} = \text{Open}$, $V_{CC} = 7\text{V}$	6N138, 6N139 HCPL2731 HCPL2730		0.05	10	20 μA

Transfer Characteristics

Symbol	Parameter	Test Conditions	Device	Min.	Typ.*	Max.	Unit
COUPLED							
CTR	Current Transfer Ratio ⁽¹⁾⁽²⁾	$I_F = 0.5\text{mA}$, $V_O = 0.4\text{V}$, $V_{CC} = 4.5\text{V}$ Each Channel	6N139 HCPL2731	400	1100		%
		$I_F = 1.6\text{mA}$, $V_O = 0.4\text{V}$, $V_{CC} = 4.5\text{V}$ Each Channel	6N139 HCPL2731	500	1300		
		$I_F = 1.6\text{mA}$, $V_O = 0.4\text{V}$, $V_{CC} = 4.5\text{V}$ Each Channel	6N138 HCPL2730	300	1300		
V_{OL}	Logic LOW Output Voltage ⁽²⁾	$I_F = 0.5\text{mA}$, $I_O = 2\text{mA}$, $V_{CC} = 4.5\text{V}$ $I_F = 1.6\text{mA}$, $I_O = 8\text{mA}$, $V_{CC} = 4.5\text{V}$ Each Channel	6N139 6N139 HCPL2731		0.08	0.4	V
		$I_F = 0.5\text{mA}$, $I_O = 15\text{mA}$, $V_{CC} = 4.5\text{V}$ Each Channel	6N139 HCPL2731		0.13	0.4	
		$I_F = 12\text{mA}$, $I_O = 24\text{mA}$, $V_{CC} = 4.5\text{V}$ Each Channel	6N139 HCPL2731		0.20	0.4	
		$I_F = 1.6\text{mA}$, $I_O = 4.8\text{mA}$, $V_{CC} = 4.5\text{V}$ Each Channel	6N138 HCPL2730		0.10	0.4	

*All Typical at $T_A = 25^\circ\text{C}$

Electrical Characteristics (Continued) ($T_A = 0$ to 70°C unless otherwise specified)**Switching Characteristics** ($V_{CC} = 5\text{V}$)

Symbol	Parameter	Test Conditions	Device	Min.	Typ.*	Max.	Unit
T_{PHL}	Propagation Delay Time to Logic LOW ⁽²⁾ (Fig. 24)	$R_L = 4.7\Omega$, $I_F = 0.5\text{mA}$	6N139			30	μs
		$T_A = 25^\circ\text{C}$			4	25	
		$R_L = 4.7\Omega$, $I_F = 0.5\text{mA}$	HCPL2731			120	
		Each Channel $T_A = 25^\circ\text{C}$			3	100	
		$R_L = 270\Omega$, $I_F = 12\text{mA}$	6N139			2	
		$T_A = 25^\circ\text{C}$			0.2	1	
		$R_L = 270\Omega$, $I_F = 12\text{mA}$, Each Channel	HCPL2730			3	
		$T_A = 25^\circ\text{C}$	HCPL2731		0.3	2	
T_{PLH}	Propagation Delay Time to Logic HIGH ⁽²⁾ (Fig. 24)	$R_L = 4.7\Omega$, $I_F = 0.5\text{mA}$	6N139			90	μs
		Each Channel	HCPL2731				
		$R_L = 4.7\Omega$, $I_F = 0.5\text{mA}$, $T_A = 25^\circ\text{C}$	6N139		12	60	
		Each Channel	HCPL2731		22		
		$R_L = 270\Omega$, $I_F = 12\text{mA}$	6N139			10	
		$T_A = 25^\circ\text{C}$			1.3	7	
		$R_L = 270\Omega$, $I_F = 12\text{mA}$, Each Channel	HCPL2730			15	
		$T_A = 25^\circ\text{C}$	HCPL2731		5	10	
ICM_H	Common Mode Transient Immunity at Logic HIGH ⁽³⁾ (Fig. 25)	$I_F = 0\text{mA}$, $ V_{CM} = 10V_{P-P}$, $T_A = 25^\circ\text{C}$, $R_L = 2.2\Omega$	6N138 6N139	1,000	10,000		$\text{V}/\mu\text{s}$
		Each Channel	HCPL2730 HCPL2731				
		$I_F = 1.6\text{mA}$, $ V_{CM} = 10V_{P-P}$, $R_L = 2.2\Omega$	6N138			50	
		$T_A = 25^\circ\text{C}$	HCPL2730/1				
ICM_L	Common Mode Transient Immunity at Logic LOW ⁽³⁾ (Fig. 25)	$I_F = 1.6\text{mA}$, $ V_{CM} = 10V_{P-P}$, $R_L = 2.2\Omega$	6N138 6N139	1,000	10,000		$\text{V}/\mu\text{s}$
		$T_A = 25^\circ\text{C}$			7	35	
		Each Channel	HCPL2730 HCPL2731				
					16		

** All Typicals at $T_A = 25^\circ\text{C}$

Electrical Characteristics (Continued) ($T_A = 0$ to 70°C unless otherwise specified)**Isolation Characteristics**

Symbol	Characteristics	Test Conditions	Min.	Typ.*	Max.	Unit
I_{I-O}	Input-Output Insulation Leakage Current ⁽⁴⁾	Relative humidity = 45%, $T_A = 25^\circ\text{C}$, $t = 5\text{s}$, $V_{I-O} = 3000\text{VDC}$			1.0	μA
V_{ISO}	Withstand Insulation Test Voltage ⁽⁴⁾	$RH \leq 50\%$, $T_A = 25^\circ\text{C}$, $I_{I-O} \leq 2\mu\text{A}$, $t = 1\text{ min.}$	2500			V_{RMS}
R_{I-O}	Resistance (Input to Output) ⁽⁴⁾	$V_{I-O} = 500\text{VDC}$		10^{12}		Ω
C_{I-O}	Capacitance (Input to Output) ⁽⁴⁾⁽⁵⁾	$f = 1\text{MHz}$		0.6		pF
I_{I-I}	Input-Input Insulation Leakage Current ⁽⁶⁾	$RH \leq 45\%$, $V_{I-I} = 500\text{VDC}$, $t = 5\text{s}$, HCPL2730/2731 only		0.005		μA
R_{I-I}	Input-Input Resistance ⁽⁶⁾	$V_{I-I} = 500\text{VDC}$, HCPL2730/2731 only		10^{11}		Ω
C_{I-I}	Input-Input Capacitance ⁽⁶⁾	$f = 1\text{MHz}$, HCPL2730/2731 only		0.03		pF

*All Typicals at $T_A = 25^\circ\text{C}$ **Notes:**

- Current Transfer Ratio is defined as a ratio of output collector current, I_O , to the forward LED input current, I_F , times 100%.
- Pin 7 open. (6N138 and 6N139 only)
- Common mode transient immunity in logic HIGH level is the maximum tolerable (positive) dV_{cm}/dt on the leading edge of the common mode pulse signal V_{CM} , to assure that the output will remain in a logic HIGH state (i.e., $V_O > 2.0\text{V}$). Common mode transient immunity in logic LOW level is the maximum tolerable (negative) dV_{cm}/dt on the trailing edge of the common mode pulse signal, V_{CM} , to assure that the output will remain in a logic LOW state (i.e., $V_O < 0.8\text{V}$).
- Device is considered a two terminal device: Pins 1, 2, 3 and 4 are shorted together and Pins 5, 6, 7 and 8 are shorted together.
- For dual channel devices, C_{I-O} is measured by shorting pins 1 and 2 or pins 3 and 4 together and pins 5 through 8 shorted together.
- Measured between pins 1 and 2 shorted together, and pins 3 and 4 shorted together.

Electrical Characteristics (Continued) $T_A = 25^\circ\text{C}$ unless otherwise specified)

Current Limiting Resistor Calculations

$$R_1 \text{ (Non-Invert)} = \frac{V_{DD1} - V_{DF} - V_{OL1}}{I_F}$$

$$R_1 \text{ (Invert)} = \frac{V_{DD1} - V_{OH1} - V_{DF}}{I_F}$$

$$R_2 = \frac{V_{DD2} - V_{OLX} (@ I_L - I_2)}{I_L}$$

Where:

V_{DD1} = Input Supply Voltage

V_{DD2} = Output Supply Voltage

V_{DF} = Diode Forward Voltage

V_{OL1} = Logic "0" Voltage of Driver

V_{OH1} = Logic "1" Voltage of Driver

I_F = Diode Forward Current

V_{OLX} = Saturation Voltage of Output Transistor

I_L = Load Current Through Resistor R2

I_2 = Input Current of Output Gate

INPUT		R1 (V)	OUTPUT						
			CMOS @ 5V	CMOS @ 10V	74XX	74LXX	74SXX	74LSXX	74HXX
			R2 (V)	R2 (V)	R2 (V)	R2 (V)	R2 (V)	R2 (V)	R2 (V)
CMOS @ 5V	NON-INV.	2000	1000	2200	750	1000	1000	1000	560
	INV.	510							
CMOS @ 10V	NON-INV.	5100							
	INV.	4700							
74XX	NON-INV.	2200							
	INV.	180							
74LXX	NON-INV.	1800							
	INV.	100							
74SXX	NON-INV.	2000							
	INV.	360							
74LSXX	NON-INV.	2000							
	INV.	180							
74HXX	NON-INV.	2000							
	INV.	180							

Fig. 1 Resistor Values for Logic Interface

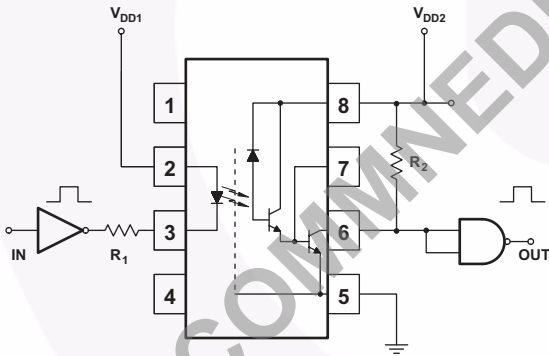

Fig. 2 Non-Inverting Logic Interface

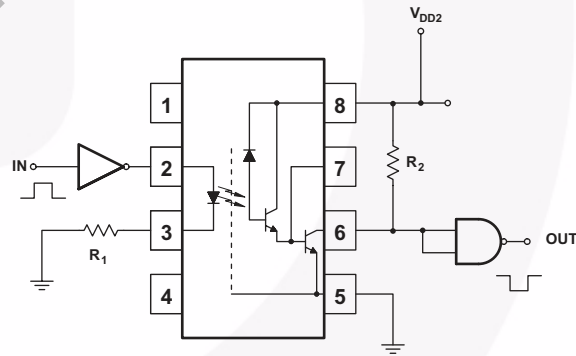

Fig. 3 Inverting Logic Interface

Typical Performance Curves

Fig. 4 LED Forward Current vs. Forward Voltage

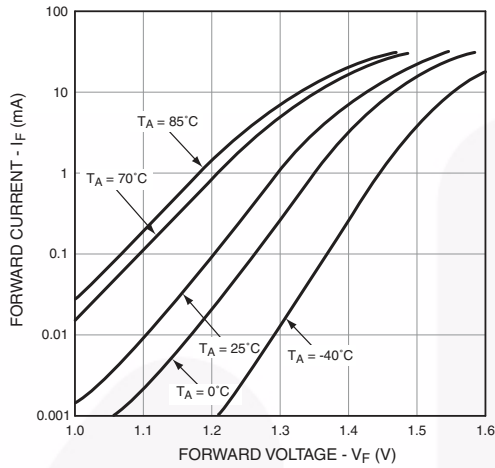

Fig. 5 LED Forward Voltage vs. Temperature

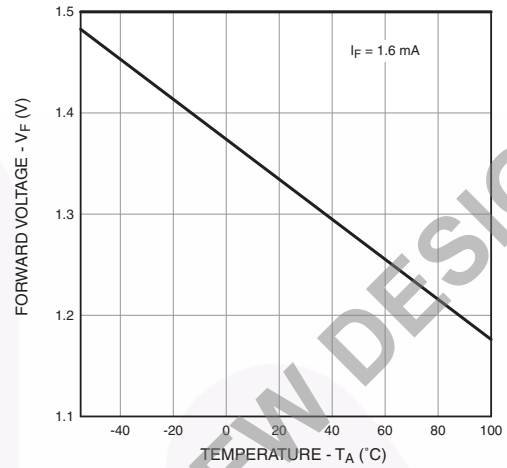

Fig. 6 Non-saturated Rise and Fall Times vs. Load Resistance (6N138 / 6N139 Only)

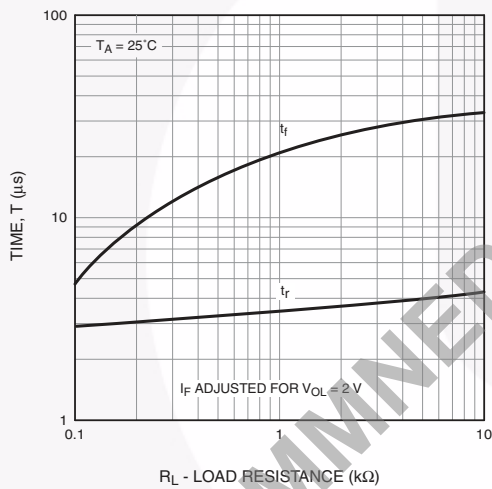

Fig. 7 Non-saturated Rise and Fall Times vs. Load Resistance (HCPL2730 / HCPL2731 Only)

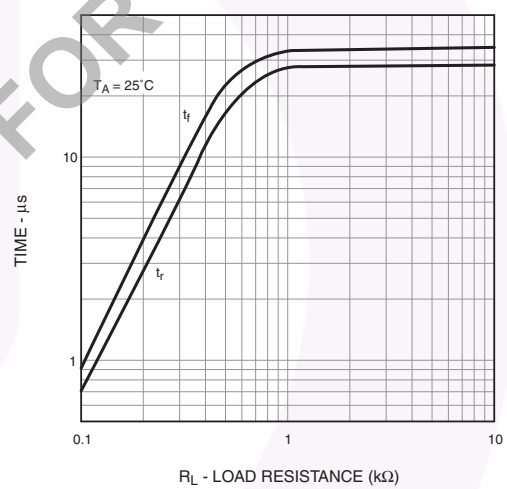

Fig. 8 Propagation Delay To Logic Low vs. Base-Emitter Resistance (HCPL2730 / HCPL2731 Only)

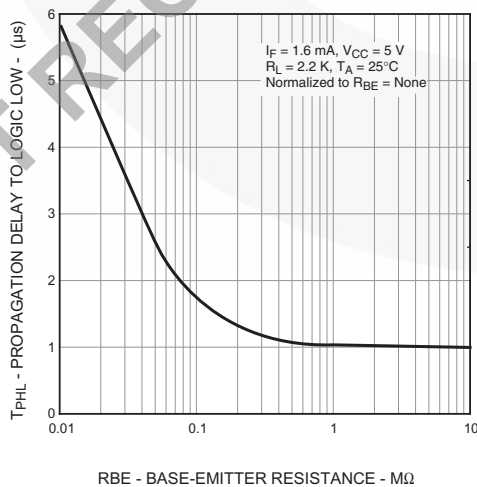
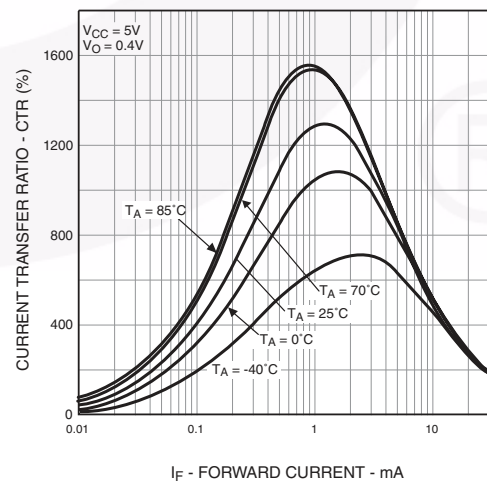

Fig. 9 Current Transfer Ratio vs. Forward Current (6N138 / 6N139 Only)



Typical Performance Curves (Continued)

Fig. 10 Current Transfer Ratio vs. Base-Emitter Resistance (6N138 / 6N139 Only)

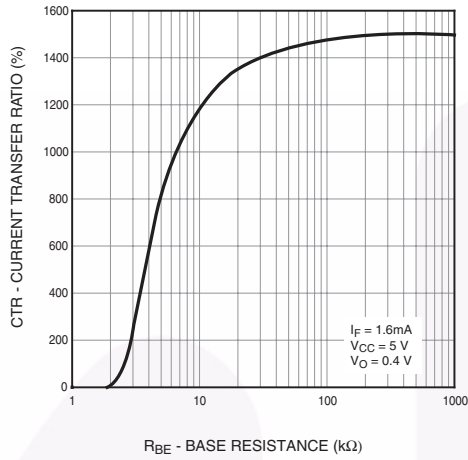

Fig. 11 Current Transfer Ratio vs. Forward Current (HCPL2730 / HCPL2731 Only)

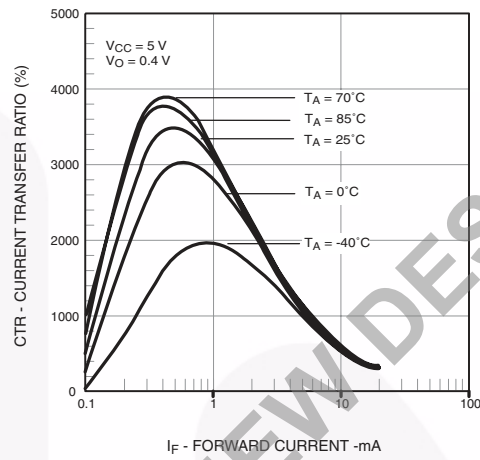

Fig. 12 Output Current vs. Output Voltage (6N138 / 6N139 Only)

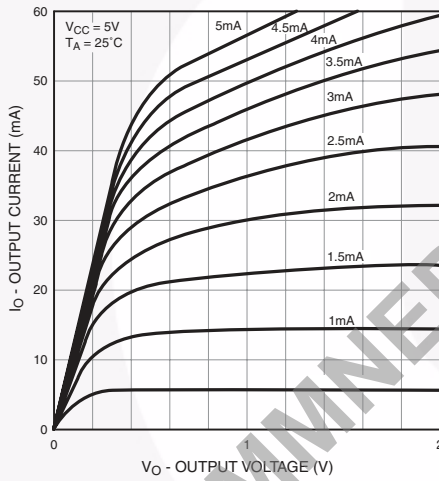

Fig. 13 Output Current vs. Output Voltage (HCPL2730 / HCPL2731 Only)

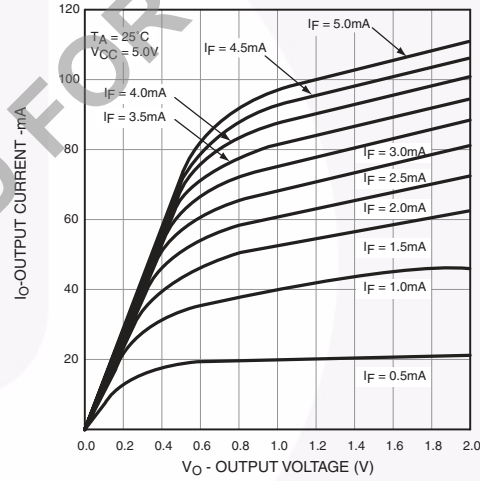

Fig. 14 Output Current vs. Input Diode Forward Current (6N138 / 6N139 Only)

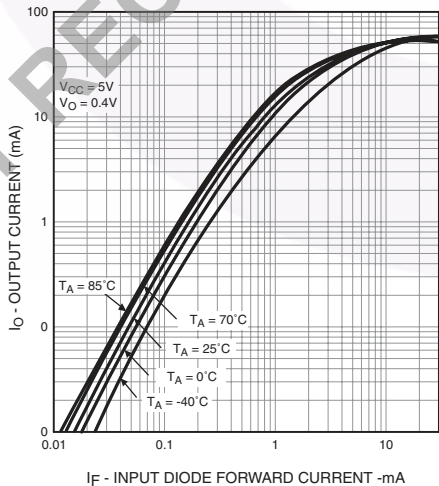
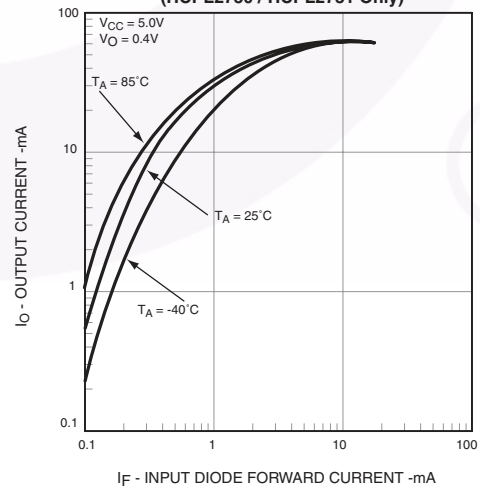

Fig. 15 Output Current vs. Input Diode Forward Current (HCPL2730 / HCPL2731 Only)



Typical Performance Curves (Continued)

Fig. 16 Logic Low Supply Current vs. Input Diode Forward Current (6N138 / 6N139 Only)

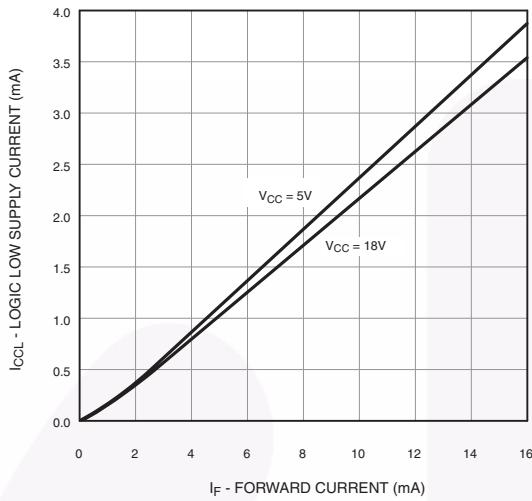

Fig. 17 Logic Low Supply Current vs. Input Diode Forward Current (HCPL2730 / HCPL2731 Only)

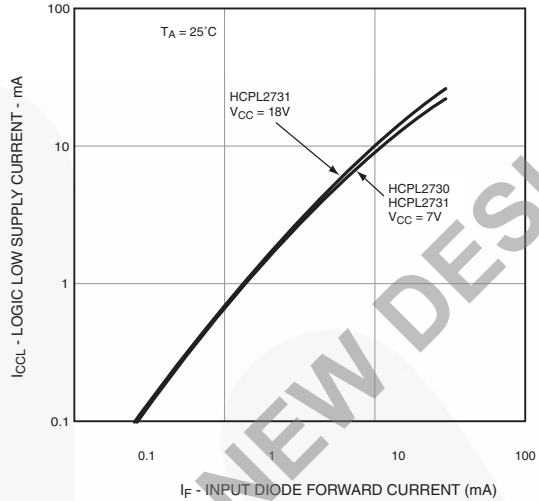

Fig. 18 Propagation Delay vs. Input Diode Forward Current (6N138 / 6N139 Only)

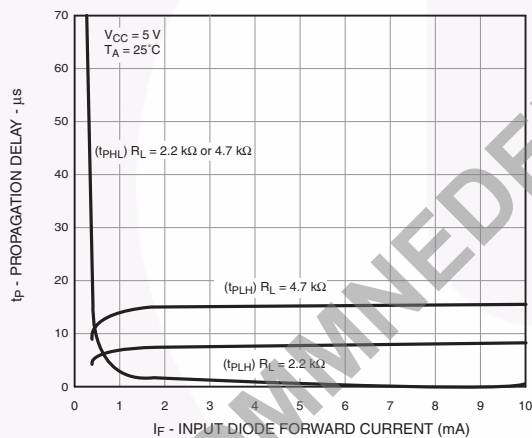

Fig. 19 Propagation Delay vs. Input Diode Forward Current (HCPL2730 / HCPL2731 Only)

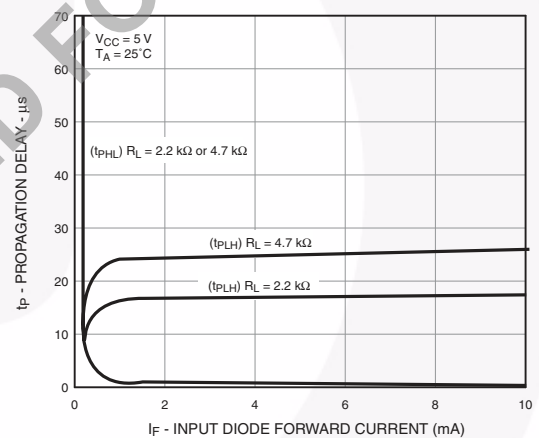

Fig. 20 Propagation Delay to Logic Low vs. Pulse Period (6N138 / 6N139 Only)

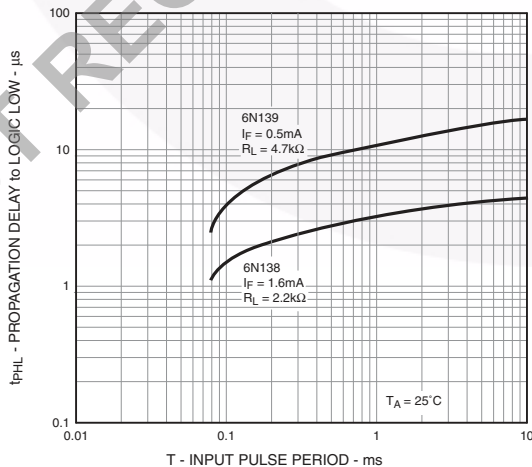
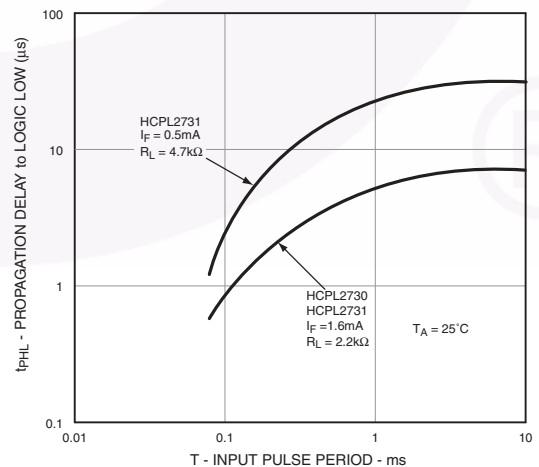

Fig. 21 Propagation Delay to Logic Low vs. Pulse Period (HCPL2730 / HCPL2731 Only)



Typical Performance Curves (Continued)

Fig. 22 Propagation Delay vs. Temperature (6N138 / 6N139 Only)

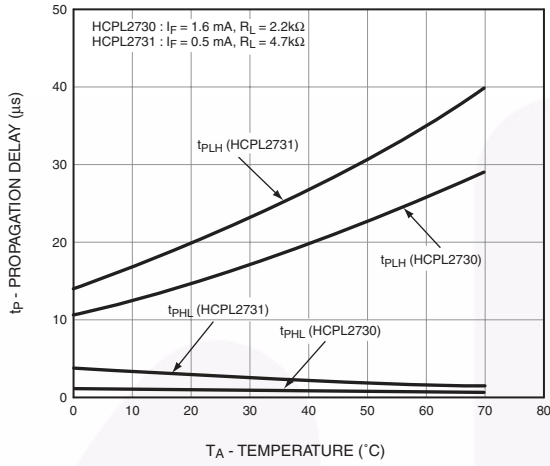
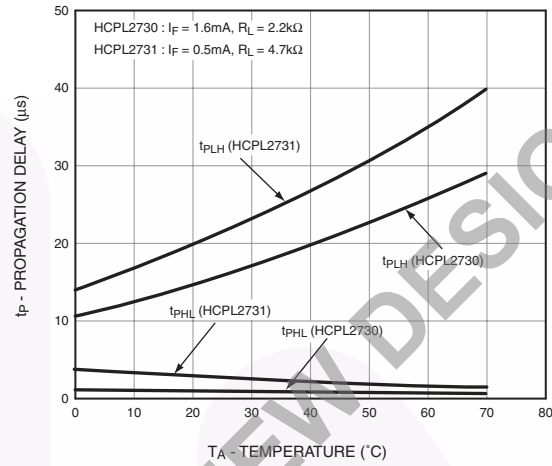

Fig. 23 Propagation Delay vs. Temperature (HCPL2730 / HCPL2731 Only)



NOT RECOMMENDED FOR NEW DESIGN

Test Circuits

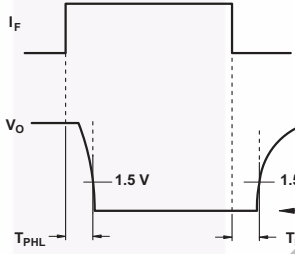
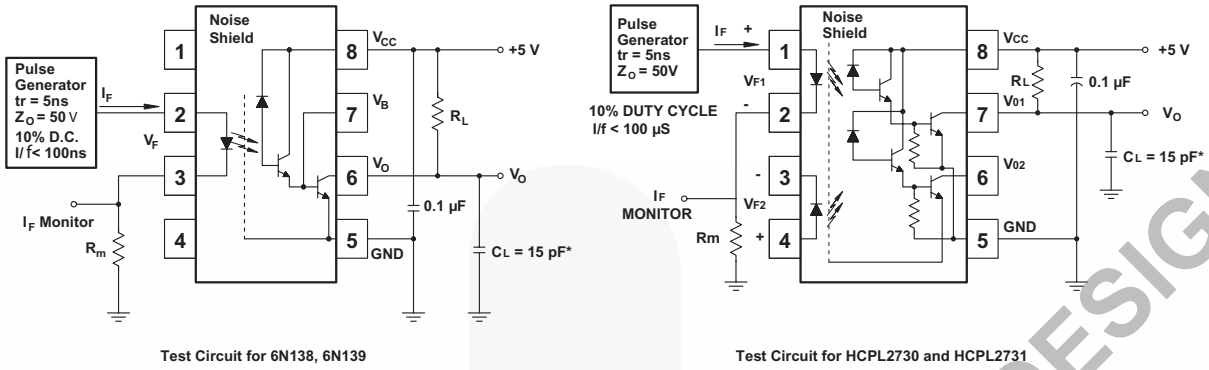

Fig. 24 Switching Time Test Circuit

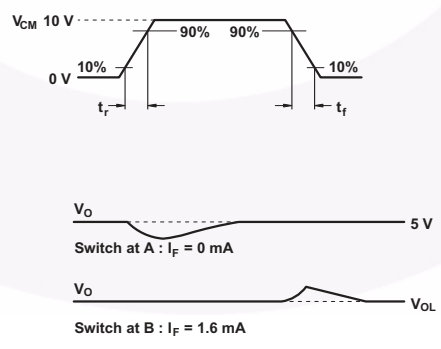
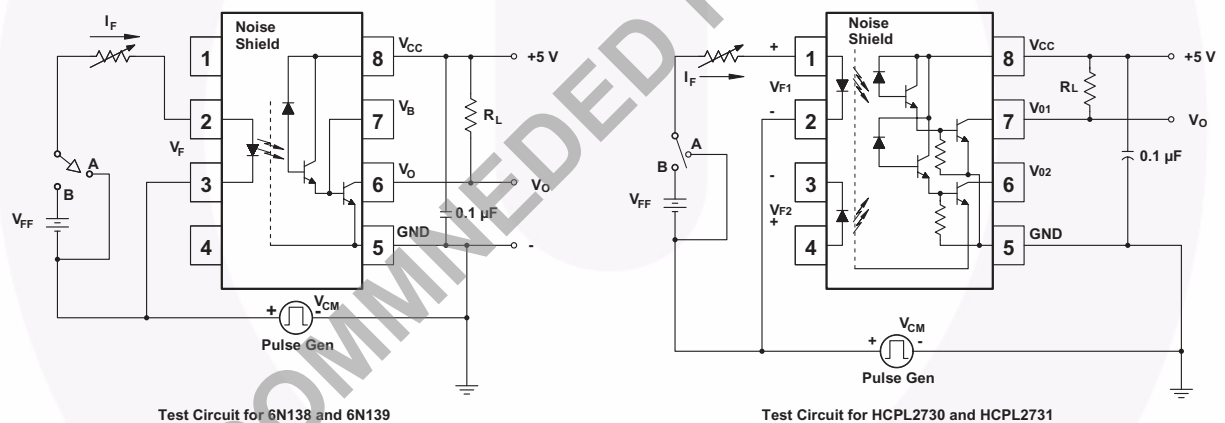
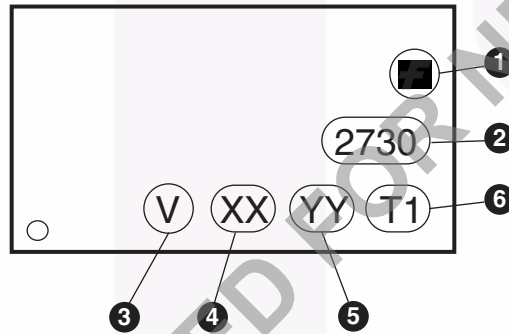

Fig. 25 Common Mode Immunity Test Circuit

Ordering Information

Option	Example Part Number	Description
No Suffix	6N138	Standard Through Hole Device, 50 pcs per tube
S	6N138S	Surface Mount Lead Bend
SD	6N138SD	Surface Mount; Tape and reel
W	6N138W	0.4" Lead Spacing
V	6N138V	VDE0884
WV	6N138WV	VDE0884; 0.4" lead spacing
SV	6N138SV	VDE0884; surface mount
SDV	6N138SDV	VDE0884; surface mount; tape and reel

Marking Information



Definitions	
1	Fairchild logo
2	Device number
3	VDE mark (Note: Only appears on parts ordered with VDE option – See order entry table)
4	Two digit year code, e.g., '07'
5	Two digit work week ranging from '01' to '53'
6	Assembly package code

Tape Specifications

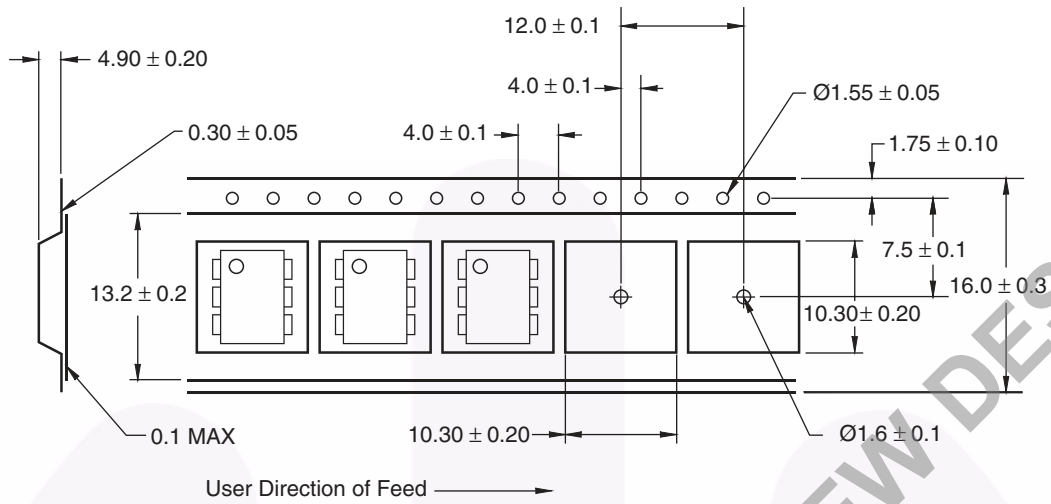

Reflow Profile

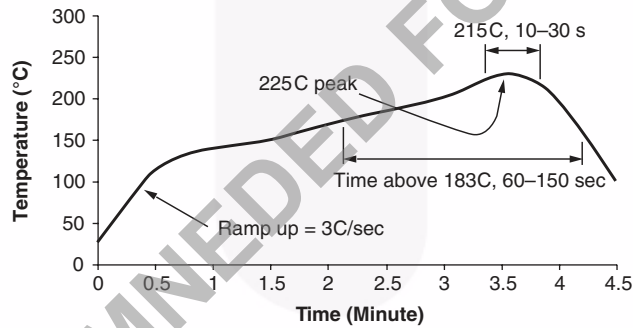

- Peak reflow temperature: 225C (package surface temperature)
- Time of temperature higher than 183C for 60-150 seconds
- One time soldering reflow is recommended

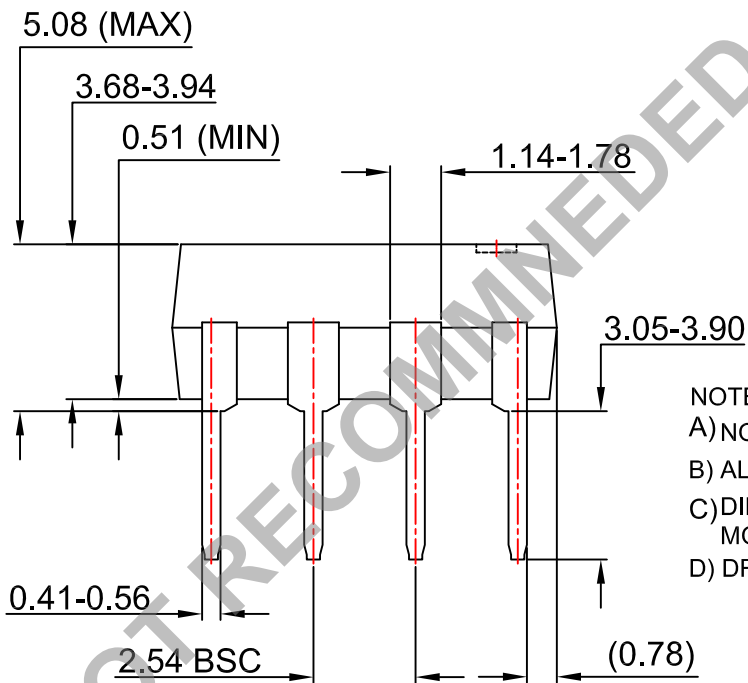
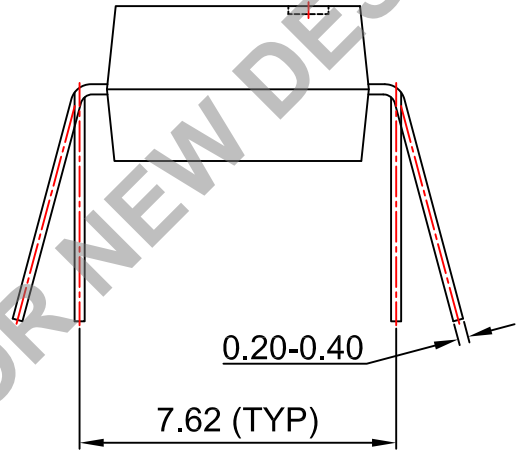
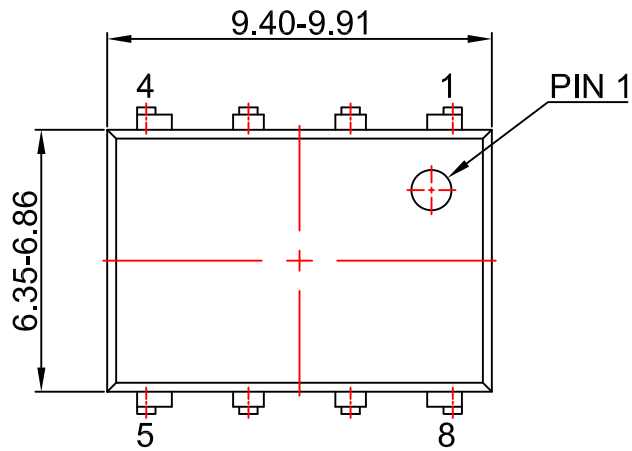

NOTES:

- A) NO STANDARD APPLIES TO THIS PACKAGE
- B) ALL DIMENSIONS ARE IN MILLIMETERS.
- C) DIMENSIONS ARE EXCLUSIVE OF BURRS, MOLD FLASH, AND TIE BAR EXTRUSION
- D) DRAWING FILENAME AND REVISION: MKT-N08GREV7



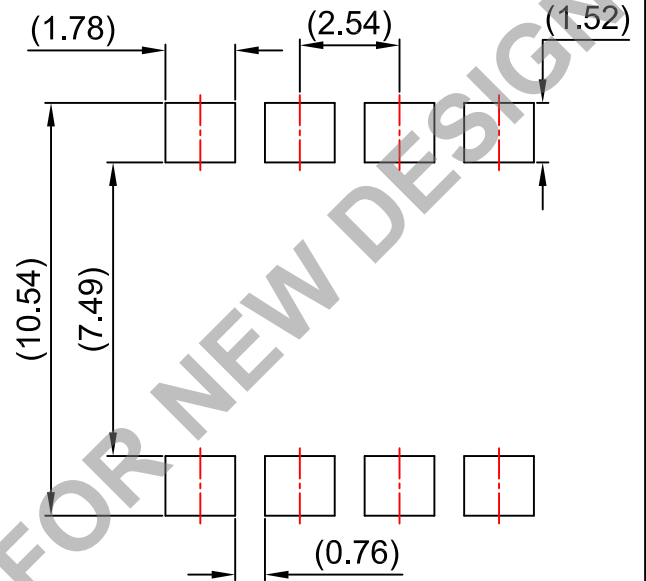
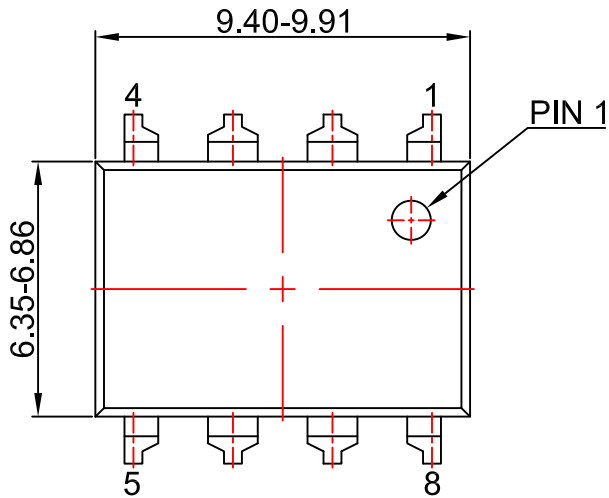

LAND PATTERN RECOMMENDATION

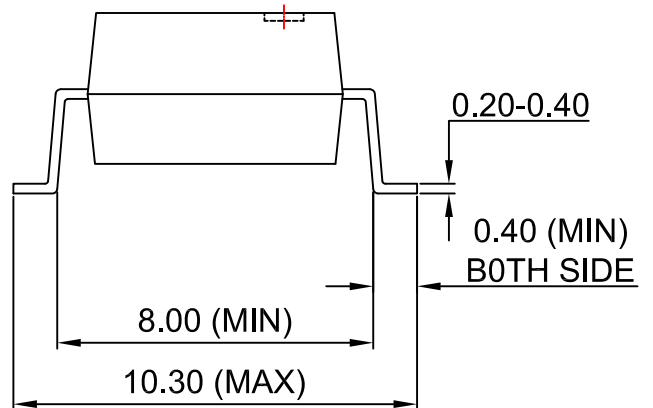
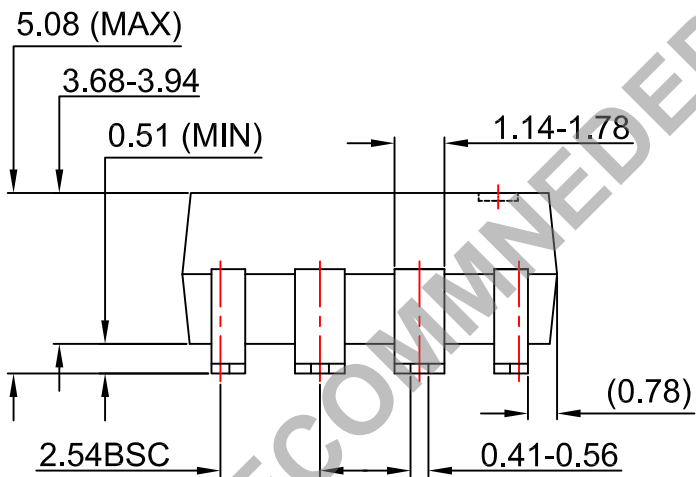

NOTES:

- A) NO STANDARD APPLIES TO THIS PACKAGE
- B) ALL DIMENSIONS ARE IN MILLIMETERS.
- C) DIMENSIONS ARE EXCLUSIVE OF BURRS, MOLD FLASH, AND TIE BAR EXTRUSION
- D) DRAWING FILENAME AND REVISION: MKT-N08Hrev7.



ON Semiconductor and  are trademarks of Semiconductor Components Industries, LLC dba ON Semiconductor or its subsidiaries in the United States and/or other countries. ON Semiconductor owns the rights to a number of patents, trademarks, copyrights, trade secrets, and other intellectual property. A listing of ON Semiconductor's product/patent coverage may be accessed at www.onsemi.com/site/pdf/Patent-Marking.pdf. ON Semiconductor reserves the right to make changes without further notice to any products herein. ON Semiconductor makes no warranty, representation or guarantee regarding the suitability of its products for any particular purpose, nor does ON Semiconductor assume any liability arising out of the application or use of any product or circuit, and specifically disclaims any and all liability, including without limitation special, consequential or incidental damages. Buyer is responsible for its products and applications using ON Semiconductor products, including compliance with all laws, regulations and safety requirements or standards, regardless of any support or applications information provided by ON Semiconductor. "Typical" parameters which may be provided in ON Semiconductor data sheets and/or specifications can and do vary in different applications and actual performance may vary over time. All operating parameters, including "Typicals" must be validated for each customer application by customer's technical experts. ON Semiconductor does not convey any license under its patent rights nor the rights of others. ON Semiconductor products are not designed, intended, or authorized for use as a critical component in life support systems or any FDA Class 3 medical devices or medical devices with a same or similar classification in a foreign jurisdiction or any devices intended for implantation in the human body. Should Buyer purchase or use ON Semiconductor products for any such unintended or unauthorized application, Buyer shall indemnify and hold ON Semiconductor and its officers, employees, subsidiaries, affiliates, and distributors harmless against all claims, costs, damages, and expenses, and reasonable attorney fees arising out of, directly or indirectly, any claim of personal injury or death associated with such unintended or unauthorized use, even if such claim alleges that ON Semiconductor was negligent regarding the design or manufacture of the part. ON Semiconductor is an Equal Opportunity/Affirmative Action Employer. This literature is subject to all applicable copyright laws and is not for resale in any manner.

PUBLICATION ORDERING INFORMATION

LITERATURE FULFILLMENT:

Literature Distribution Center for ON Semiconductor
19521 E. 32nd Pkwy, Aurora, Colorado 80011 USA
Phone: 303-675-2175 or 800-344-3860 Toll Free USA/Canada
Fax: 303-675-2176 or 800-344-3867 Toll Free USA/Canada
Email: orderlit@onsemi.com

N. American Technical Support: 800-282-9855 Toll Free
USA/Canada
Europe, Middle East and Africa Technical Support:
Phone: 421 33 790 2910
Japan Customer Focus Center
Phone: 81-3-5817-1050

ON Semiconductor Website: www.onsemi.com
Order Literature: <http://www.onsemi.com/orderlit>
For additional information, please contact your local
Sales Representative