

PRODUCT NUMBER
SEE TABLE

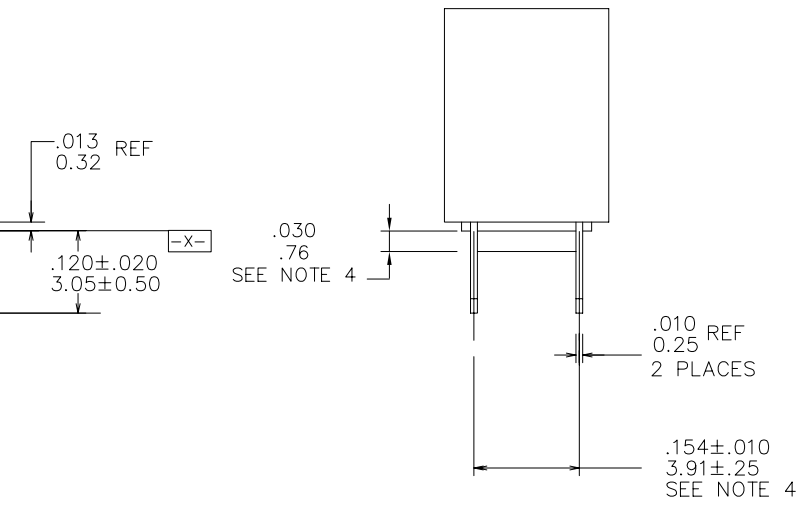
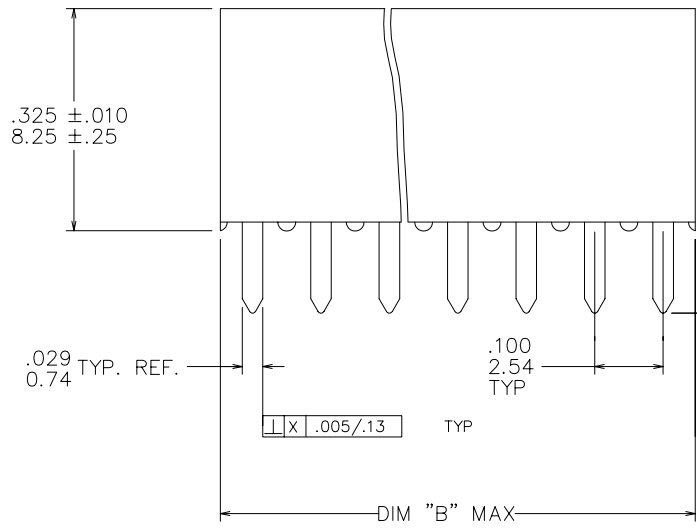
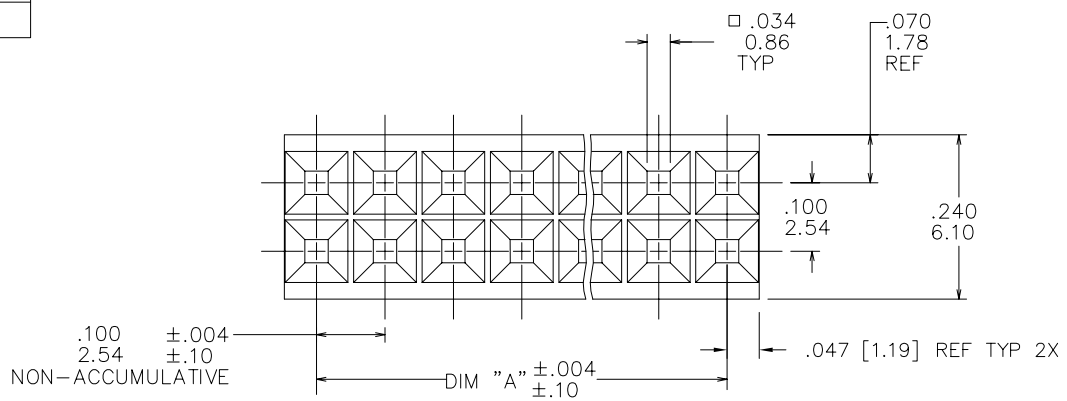

Copyright FCI

mat'l. code		surface		tolerance		projection		product family	
NOTES 1 & 2		ISO 1302 ✓		ISO 406		ISO 1101		CARD CONN	
ltr	ecr	no	dr	date	tolerances unless otherwise specified				
F	V11595	JGS	07/24/91		angles	linear	.XX±.01/.X±.3	title	
G	v61741	MDF	01/13/97				.XXX±.0.005/.XX±.13	VERT. CARD CONNECTOR	
H	V12708	GIP	12/11/01	0'±2'			.XXXX±.0020/.XXX±.051	.154/3.91 CTR DOUBLE ROW	
J	M05-0216	ERE	10/11/05	dr	J.SHREINER	7/21/91	scale 4:1		
K	M06-0210	MHT	6/03/06	engr	M.HAHN	7/21/91	FCI		
L	M07-0143	ERE	03/03/07	chr	M.HAHN	7/21/91	dwg no		
				appd	M.HAHN	7/21/91	76054		
sheet index		revision	L	L	L	L	L	L	sheet 1 of 6 size
		sheet	1	2	3	4	5	6	A3
									type Product Customer Drawing

form: A3

PRODUCT NUMBER

SEE TABLE

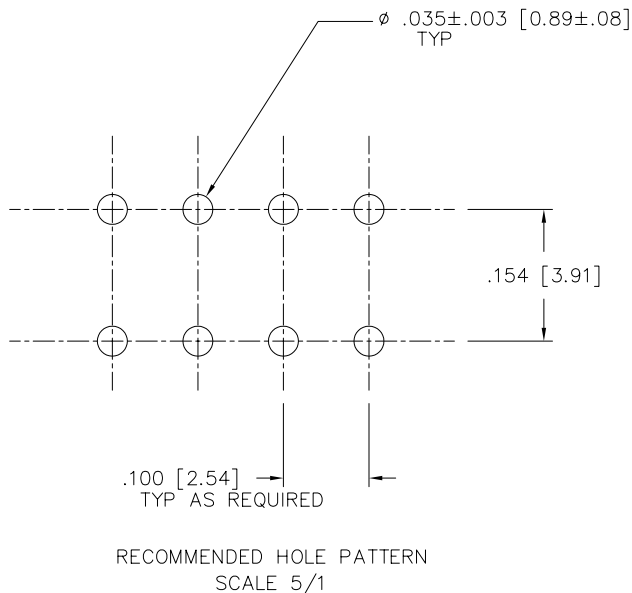

NOTES:

- ① HOUSING MAT'L: FILLED POLYESTER, FLAME RETARDANT PER UL 94V-0. COLOR : BLACK.
- ② TERMINAL MATERIAL AND PLATING: SEE TABULATION.
- ③ RECOMMENDED PIN SIZE: $.025 \pm .001 / .64 \pm .03$ SQUARE. RECOMMENDED PIN LENGTH: $.210 \pm .020 / 5.33 \pm .51$.
- ④ $.154 / 3.91$ DIM. APPLIES AT $.030 / .08$ BELOW DATUM $\boxed{-X-}$
- ⑤ MARKING: FCI PART NUMBER AND DATE CODE LEGIBLE ON TUBE LABEL
- ⑥ ADD "LF" SUFFIX AT THE END OF PART NUMBER FOR LEAD FREE OPTION.
- ⑦ THESE PRODUCTS MEET EUROPEAN UNION DIRECTIVES AND OTHER COUNTRY REGULATIONS AS DESCRIBED IN GS-22-008.
- ⑧ THIS PART WILL WITHSTAND EXPOSURE TO 260°C PEAK TEMPERATURE FOR 20 SECONDS IN WAVE SOLDER, INFRA-RED OR VAPOR PHASE SOLDER PROCESS.
- ⑨ "THIS PRODUCT HAS 100% TIN PLATING IN THE INTERFACE AND HAS NOT BEEN TESTED FOR WHISKER GROWTH IN ALL INTERCONNECT ENVIRONMENTS."



FCIconnect.com

Copyright FCI

mat'l. code		surface ISO 1302 <input checked="" type="checkbox"/>		tolerance ISO 406 ISO 1101		projection 		product family CARD CONN	
ltr		ecn no		dr		date		tolerances unless otherwise specified	
L								angles linear	
								.XX±.01/.X±.3	
								.XXX±.0.005/.XX±.13	
								.XXXX±.0020/.XXX±.051	
								0°±2'	
				dr		J.SHREINER		7/21/91	
				enr		M.HAHN		7/21/91	
				chr		M.HAHN		7/21/91	
				appd		M.HAHN		7/21/91	
sheet index		revision sheet							



title
VERT. CARD CONNECTOR
.154/3.91 CTR DOUBLE ROW

dwg no
76054

sheet 2 of 6 size
A3

type Product Customer Drawing

PRODUCT NO	SIZE	DIM A	DIM B	MATERIAL AND PLATING	MISC.	RESTRICTED	LEAD FREE OPTION
76054-001	UNASSIGNED						
-002	2 X 2	.100/2.54	.200/5.08	BODY MATERIAL: BRASS BODY PLATING: 40u"/1.02u GOLD OVER 50u"/1.27u NICKEL IN CONTACT AREA. SPRING MAT'L: BeCu HEAT TREATED SPRING PLATING: GOLD FLASH			NOTE 6,7
-003	2 X 3	.200/5.08	.300/7.62				
-004	2 X 4	.300/7.62	.400/10.16				
-005	2 X 5	.400/10.16	.500/12.70				
-006	2 X 6	.500/12.70	.600/15.24				
-007	2 X 7	.600/15.24	.700/17.78				
-008	2 X 8	.700/17.78	.800/20.32				
-009	2 X 9	.800/20.32	.900/22.86				
-010	2 X 10	.900/22.86	1.000/25.40				
-011	2 X 11	1.000/25.40	1.100/27.94				
-012	2 X 12	1.100/27.94	1.200/30.48				
-013	2 X 13	1.200/30.48	1.300/33.02				
-014	2 X 14	1.300/33.02	1.400/35.56				
-015	2 X 15	1.400/35.56	1.500/38.10				
-016	2 X 16	1.500/38.10	1.600/40.64				
-017	2 X 17	1.600/40.64	1.700/43.18				
-018	2 X 18	1.700/43.18	1.800/45.72				
-019	2 X 19	1.800/45.72	1.900/48.26				
-020	2 X 20	1.900/48.26	2.000/50.08				
-021	2 X 21	2.000/50.08	2.100/53.34				
-022	2 X 22	2.100/53.34	2.200/55.88				
-023	2 X 23	2.200/55.88	2.300/58.42				
-024	2 X 24	2.300/58.42	2.400/60.96				
-025	2 X 25	2.400/60.96	2.500/63.50				
-026	2 X 26	2.500/63.50	2.600/66.04				
-027	2 X 27	2.600/66.04	2.700/68.58				
76054-028	2 X 28	2.700/68.58	2.800/71.12				



Copyright FCI

mat'l. code		surface ISO 1302 <input checked="" type="checkbox"/>		tolerance ISO 406 ISO 1101		projection 		product family CARD CONN	
ltr		ecn no dr		date		tolerances unless otherwise specified		title	
L						<input type="checkbox"/> .XX±.01/.X±.3 <input type="checkbox"/> linear <input type="checkbox"/> .XXX±.0.005/.XX±.13 <input type="checkbox"/> .XXXX±.0020/.XXX±.051		INCH/MM scale 4:1	
						dr J.SHREINER 7/21/91		VERT. CARD CONNECTOR .154/3.91 CTR DOUBLE ROW	
						enr M.HAHN 7/21/91		dwg no 76054 sheet 3 of 6 size A3	
						chr M.HAHN 7/21/91		type Product Customer Drawing	
						appd M.HAHN 7/21/91			
sheet index		revision sheet							



form: A3

PRODUCT NO	SIZE	DIM A	DIM B	MATERIAL AND PLATING	MISC.	RESTRICTED	LEAD FREE OPTION
76054-029	2 X 29	2.800/71.12	2.900/73.66	BODY MATERIAL: BRASS BODY PLATING: 40u"/1.02u GOLD OVER 50u"/1.27u NICKEL IN CONTACT AREA. SPRING MAT'L: BeCu HEAT TREATED SPRING PLATING: GOLD FLASH			NOTE 6,7
-030	2 X 30	2.900/73.66	3.000/76.20				
-031	2 X 31	3.000/76.20	3.100/78.74				
-032	2 X 32	3.100/78.74	3.200/81.28				
-033	2 X 33	3.200/81.28	3.300/83.82				
-034	2 X 34	3.300/83.82	3.400/86.36				
-035	2 X 35	3.400/86.36	3.500/88.90				
-036	2 X 36	3.500/88.90	3.600/91.44				NOTE 6,7
-037	UNASSIGNED						
A -038	2 X 2	.100/2.54	.200/5.08	BODY MATERIAL: BRASS BODY PLATING: 100u"/2.54u THICK Sn PLATE SPRING MAT'L: BeCu HEAT TREATED SPRING PLATING: 30u"/.76u MIN ELECTROLESS TIN			NOTE 6,7
-039	2 X 3	.200/5.08	.300/7.62				
-040	2 X 4	.300/7.62	.400/10.16				
-041	2 X 5	.400/10.16	.500/12.70				
-042	2 X 6	.500/12.70	.600/15.24				
-043	2 X 7	.600/15.24	.700/17.78				
-044	2 X 8	.700/17.78	.800/20.32				
-045	2 X 9	.800/20.32	.900/22.86				
-046	2 X 10	.900/22.86	1.000/25.40				
-047	2 X 11	1.000/25.40	1.100/27.94				
-048	2 X 12	1.100/27.94	1.200/30.48				
-049	2 X 13	1.200/30.48	1.300/33.02				
B -050	2 X 14	1.300/33.02	1.400/35.56				
-051	2 X 15	1.400/35.56	1.500/38.10				
-052	2 X 16	1.500/38.10	1.600/40.64				
-053	2 X 17	1.600/40.64	1.700/43.18				
-054	2 X 18	1.700/43.18	1.800/45.72				
-055	2 X 19	1.800/45.72	1.900/48.26				
76054-056	2 X 20	1.900/48.26	2.000/50.08				NOTE 6,7



Copyright FCJ

mat'l. code		surface ISO 1302 <input checked="" type="checkbox"/>		tolerance ISO 406 ISO 1101		projection 		product family CARD CONN	
ltr		ecn no		date		tolerances unless otherwise specified		title	
L						.XX±.01/.X±.3		VERT. CARD CONNECTOR	
						linear .XXX±.0.005/.XX±.13		.154/3.91 CTR DOUBLE ROW	
						0'±2'		scale 4:1	
						.XXXX±.0020/.XXX±.051		dwg no sheet 4 of 6 size	
				dr J.SHREINER 7/21/91				76054 A3	
				enr M.HAHN 7/21/91				type Product Customer Drawing	
				chr M.HAHN 7/21/91					
				appd M.HAHN 7/21/91					
sheet index		revision sheet							

PRODUCT NO	SIZE	DIM A	DIM B	MATERIAL AND PLATING	MISC.	RESTRICTED	LEAD FREE OPTION
76054-057	2 X 21	2.000/50.08	2.100/53.34	BODY MATERIAL: BRASS BODY PLATING: 100u"/2.54u THICK Sn PLATE SPRING MAT'L: BeCu HEAT TREATED SPRING PLATING: 30u/.76u MIN ELECTROLESS TIN			NOTE 6,7
-058	2 X 22	2.100/53.34	2.200/55.88				
-059	2 X 23	2.200/55.88	2.300/58.42				
-060	2 X 24	2.300/58.42	2.400/60.96				
-061	2 X 25	2.400/60.96	2.500/63.50				
-062	2 X 26	2.500/63.50	2.600/66.04				
-063	2 X 27	2.600/66.04	2.700/68.58				
-064	2 X 28	2.700/68.58	2.800/71.12				
-065	2 X 29	2.800/71.12	2.900/73.66				
-066	2 X 30	2.900/73.66	3.000/76.20				
-067	2 X 31	3.000/76.20	3.100/78.74				
-068	2 X 32	3.100/78.74	3.200/81.28				
-069	2 X 33	3.200/81.28	3.300/83.82				
-070	2 X 34	3.300/83.82	3.400/86.36				
-071	2 X 35	3.400/86.36	3.500/88.90				
-072	2 X 36	3.500/88.90	3.600/91.44				
-073	UNASSIGNED						
-074	2 X 2	.100/2.54	.200/5.08	BODY MATERIAL: Cu Ni BODY PLATING: 10u"/.25u Au FLASH INSIDE CONTACT AREA ONLY WITH .001/.03 MIN HIGH GOLD DOT SPRING MAT'L: BeCu HEAT TREATED SPRING PLATING: GOLD FLASH			NOTE 6,7
-075	2 X 3	.200/5.08	.300/7.62				
-076	2 X 4	.300/7.62	.400/10.16				
-077	2 X 5	.400/10.16	.500/12.70				
-078	2 X 6	.500/12.70	.600/15.24				
-079	2 X 7	.600/15.24	.700/17.78				
-080	2 X 8	.700/17.78	.800/20.32				
-081	2 X 9	.800/20.32	.900/22.86				
-082	2 X 10	.900/22.86	1.000/25.40				
-083	2 X 11	1.000/25.40	1.100/27.94				
76054-084	2 X 12	1.100/27.94	1.200/30.48				NOTE 6,7



FCJconnect.com

Copyright FCJ

mat'l. code		surface ISO 1302 <input checked="" type="checkbox"/>		tolerance ISO 406 ISO 1101		projection 		product family CARD CONN	
ltr		ecn no		dr		date		title	
L								VERT. CARD CONNECTOR	
								.154/3.91 CTR DOUBLE ROW	
								dwg no	
								76054	
								sheet 5 of 6 size	
								A3	
								type Product Customer Drawing	
sheet index		revision sheet							



PRODUCT NO	SIZE	DIM A	DIM B	MATERIAL AND PLATING	MISC.	RESTRICTED	LEAD FREE OPTION
76054-085	2 X 13	1.200/30.48	1.300/33.02	BODY MATERIAL: Cu Ni BODY PLATING: 10u"/.25u Au FLASH INSIDE CONTACT AREA ONLY WITH .001/.03 MIN HIGH GOLD DOT SPRING MAT'L: BeCu HEAT TREATED SPRING PLATING: GOLD FLASH			NOTE 6,7
-086	2 X 14	1.300/33.02	1.400/35.56				
-087	2 X 15	1.400/35.56	1.500/38.10				
-088	2 X 16	1.500/38.10	1.600/40.64				
-089	2 X 17	1.600/40.64	1.700/43.18				
-090	2 X 18	1.700/43.18	1.800/45.72				
-091	2 X 19	1.800/45.72	1.900/48.26				
-092	2 X 20	1.900/48.26	2.000/50.08				
-093	2 X 21	2.000/50.08	2.100/53.34				
-094	2 X 22	2.100/53.34	2.200/55.88				
-095	2 X 23	2.200/55.88	2.300/58.42				
-096	2 X 24	2.300/58.42	2.400/60.96				
-097	2 X 25	2.400/60.96	2.500/63.50				
-098	2 X 26	2.500/63.50	2.600/66.04				
-099	2 X 27	2.600/66.04	2.700/68.58				
-100	2 X 28	2.700/68.58	2.800/71.12				
-101	2 X 29	2.800/71.12	2.900/73.66				
-102	2 X 30	2.900/73.66	3.000/76.20				
-103	2 X 31	3.000/76.20	3.100/78.74				
-104	2 X 32	3.100/78.74	3.200/81.28				
-105	2 X 33	3.200/81.28	3.300/83.82				
-106	2 X 34	3.300/83.82	3.400/86.36				
-107	2 X 35	3.400/86.36	3.500/88.90				
-108	2 X 36	3.500/88.90	3.600/91.44				
76054-109	2 X 17	1.600/40.64	1.700/43.18	SPL MARKING	YES	NOTE 6,7	



FCJconnect.com

Copyright FCJ

mat'l. code		surface ISO 1302 <input checked="" type="checkbox"/>		tolerance ISO 406 ISO 1101		projection 		product family CARD CONN	
ltr	ecn no	dr	date	tolerances unless otherwise specified		INCH/MM		title	
L				angles	linear	.XX±.01/.X±.3		VERT. CARD CONNECTOR	
				0'±2'		.XXX±.0.005/.XX±.13		.154/3.91 CTR DOUBLE ROW	
						.XXXX±.0020/.XXX±.051		scale 4:1	
				dr	J.SHREINER	7/21/91		dwg no	
				enr	M.HAHN	7/21/91		sheet 6 of 6 size	
				chr	M.HAHN	7/21/91		76054 A3	
				appd	M.HAHN	7/21/91		type Product Customer Drawing	
sheet index	revision sheet								



form: A3