

MATERIALS AND FINISHES:

BODY: LCP

CENTER CONTACT: BRASS
 PLATED GOLD (8μ-in MIN)
 OVER NICKEL PHOSPHOR (80μ-in MIN)
 OVER COPPER (20μ-in MIN)

OUTER CONTACT: BRASS
 PLATED GOLD (2μ-in MIN)
 OVER NICKEL (80μ-in MIN)

INSULATOR: LCP

MYLAR: POLYIMIDE FILM

ELECTRICAL CHARACTERISTICS:

FREQUENCY RANGE: DC-10 GHz
 VSWR (MAX) / RETURN LOSS (MAX)

DC - 4 GHz	4-6 GHz
1.07 / -30dB	1.12 / -25dB

INSERTION LOSS: *0.05√F (GHz) dB MAX
 *COAXIAL TRANSMISSION LINE ONLY
 @ MIDDLE MISALIGNMENT (@ 1mm IN
 THE AXIAL WORKING RANGE 0 ~ 2mm,
 MAXIMUM AXIAL WORKING RANGE OF
 APPLICATION 2.4mm)

VOLTAGE RATING: 330 Vrms AT SEA LEVEL
 DIELECTRIC WITHSTANDING VOLTAGE: 1000 Vrms
 INSULATION RESISTANCE: 5000 MΩ

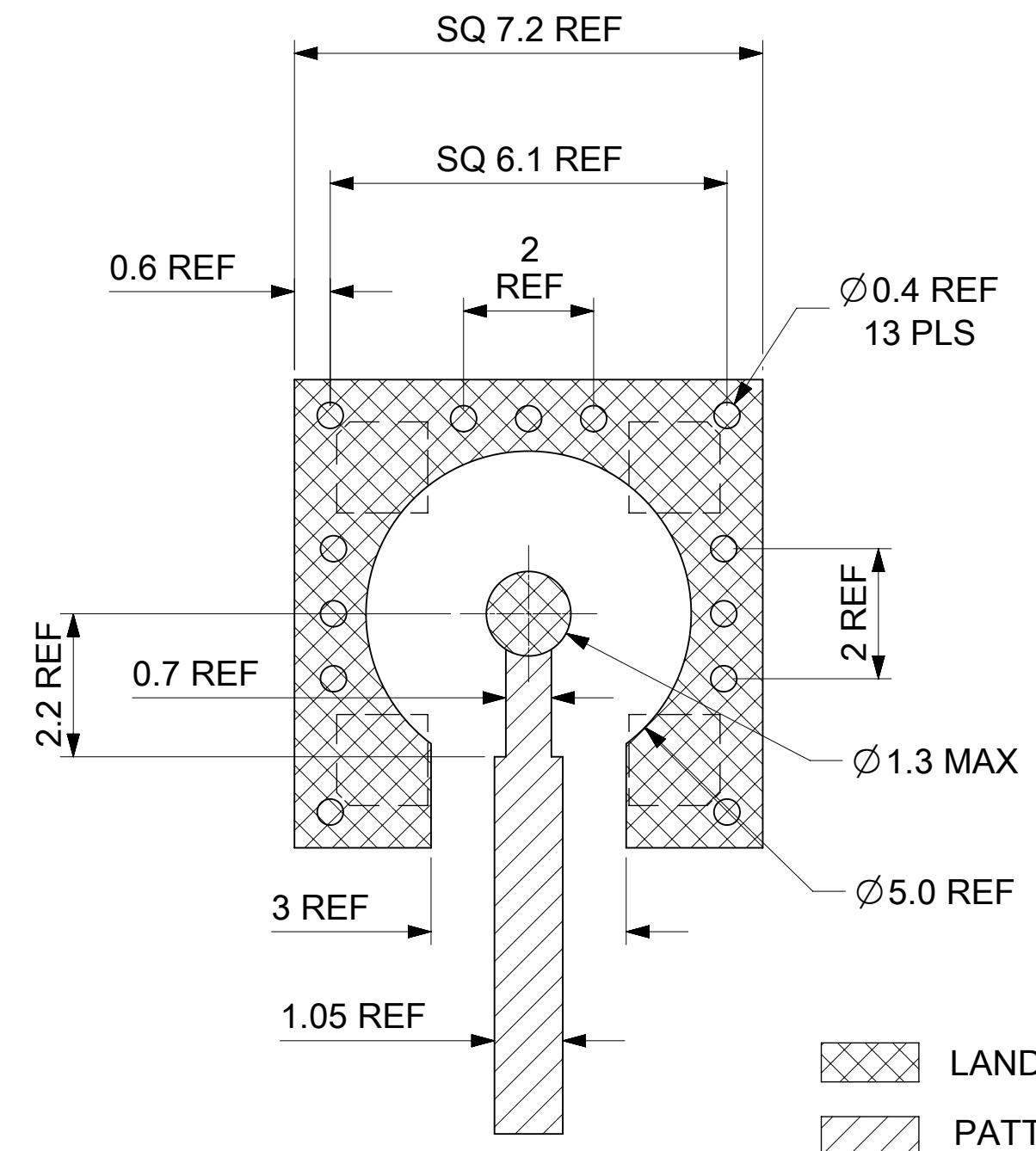
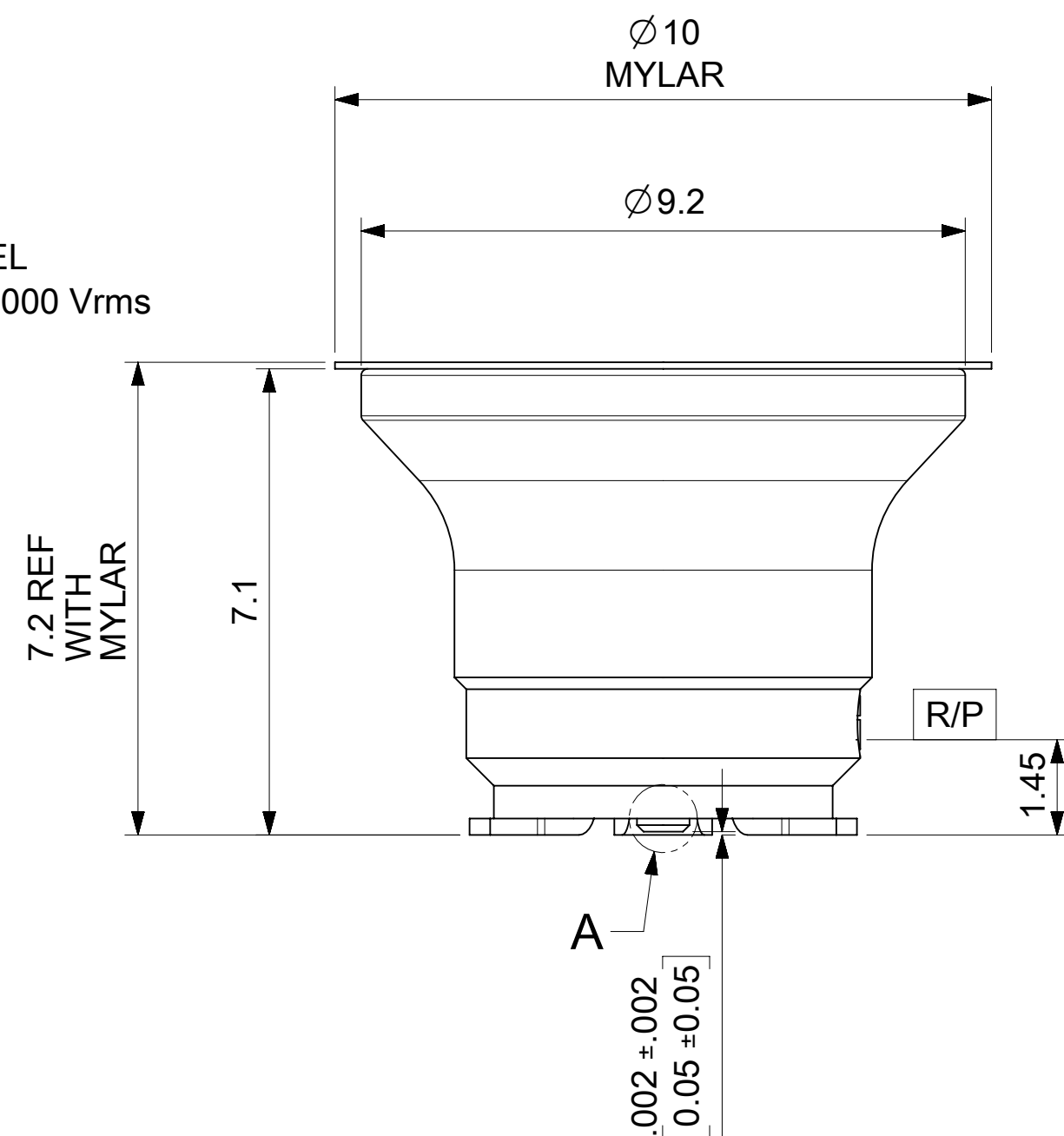
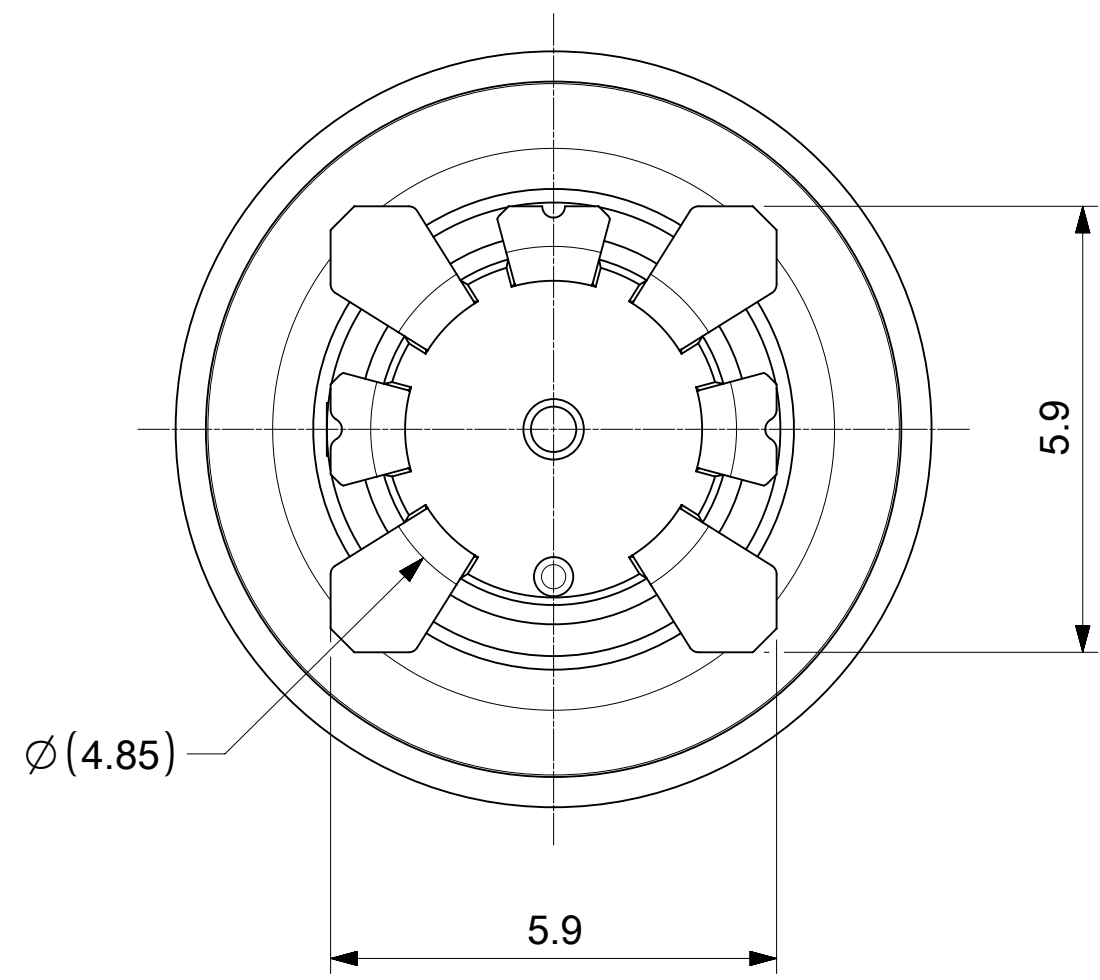

LANDS FOR SOLDER PASTE
 PATTERN
 CONSTRUCT LINE JUST INDICATE THE DIRECTION OF CONNECTOR

NOTE: DUE TO THE POTENTIAL LARGE VARIATION OF PERFORMANCES DEPENDING ON PCB AND LINE PARAMETERS, WE RECOMMEND THE USER TO PROCESS A RF ANALYZE OF THE CONNECTOR MOUNTED ON HIS PCB. ABOVE LAYOUT IS RECOMMENDED FOR PCB: RO4350B 20MIL

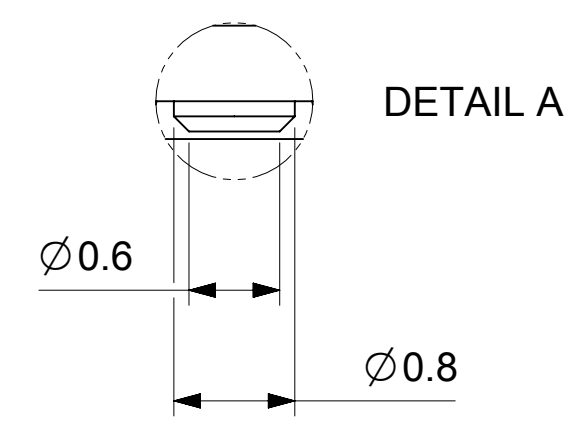
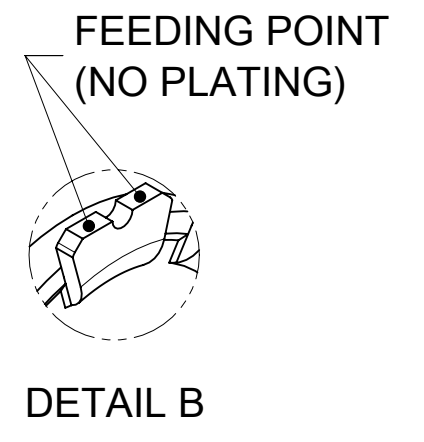
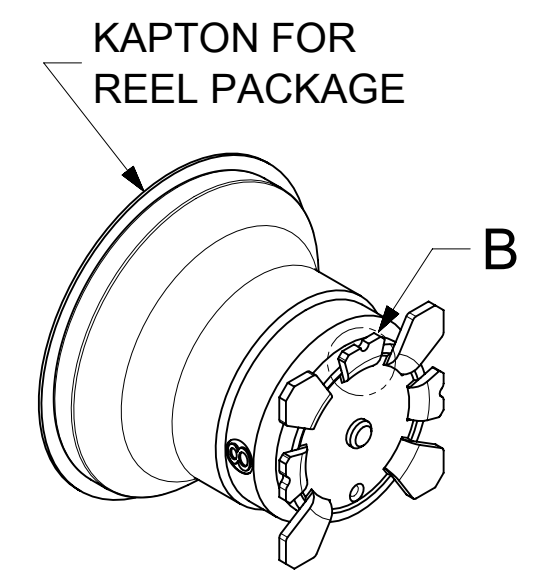

73420-6220	TAPE AND REEL WITH MYLAR
PART NO.	PACKAGING

PS-89675-3760	ELEC/MECH PERFORMANCE
SPECIFICATION	DESCRIPTION

DOCUMENT STATUS	P1	RELEASE DATE	2023/02/09	02:36:15
-----------------	----	--------------	------------	----------

THIS DRAWING CONTAINS INFORMATION THAT IS PROPRIETARY TO MOLEX ELECTRONIC TECHNOLOGIES, LLC AND SHOULD NOT BE USED WITHOUT WRITTEN PERMISSION											
DIMENSION UNITS	SCALE	CURRENT REV DESC: UPDATE VIEWS FOR PACKING DIRECTION & RECOMMENDED PCB LAYOUT ; ADD PLATING THICKNESS PER EWR #12293-P (PCN #513327)					molex				
mm	NTS										
GENERAL TOLERANCES (UNLESS SPECIFIED)		EC NO: 737826					SMP-MAX EVO II PLUG SLIDE TYPE PCB SMT EWR-12293				
ANGULAR TOL	± °	DRWN: RYEH 2022/10/26									
4 PLACES	±	CHK'D: YCHENG 2023/02/09					PRODUCT CUSTOMER DRAWING				
3 PLACES	±	APPR: YCHENG 2023/02/09									
2 PLACES	± 0.13	INITIAL REVISION:					DOCUMENT NUMBER		DOC TYPE	DOC PART	REVISION
1 PLACE	± 0.25	DRWN: RYEH 2018/07/20					734206220		PSD	000	A5
0 PLACES	± 0.38	APPR: YCHENG 2020/07/08					MATERIAL NUMBER		CUSTOMER		SHEET NUMBER
DRAFT WHERE APPLICABLE MUST REMAIN WITHIN DIMENSIONS		THIRD ANGLE PROJECTION	DRAWING	SERIES	MATERIAL NUMBER		CUSTOMER		SHEET NUMBER		
			C-SIZE	73420	SEE TABLE				1 OF 3		

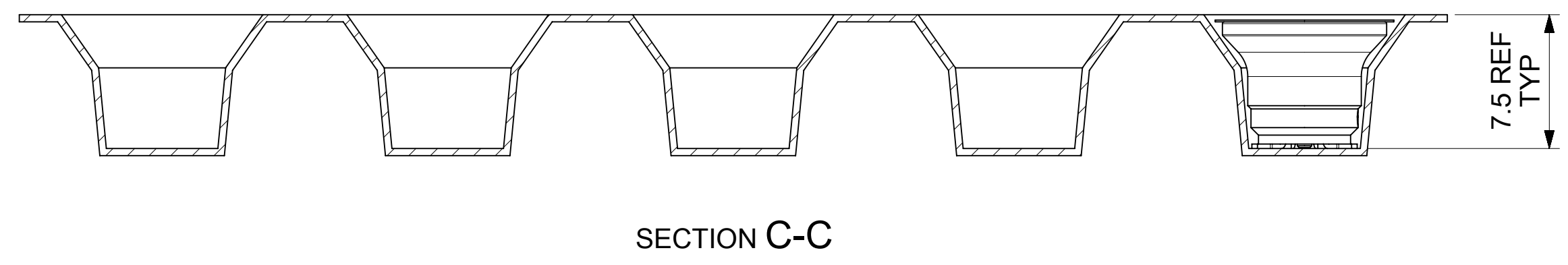
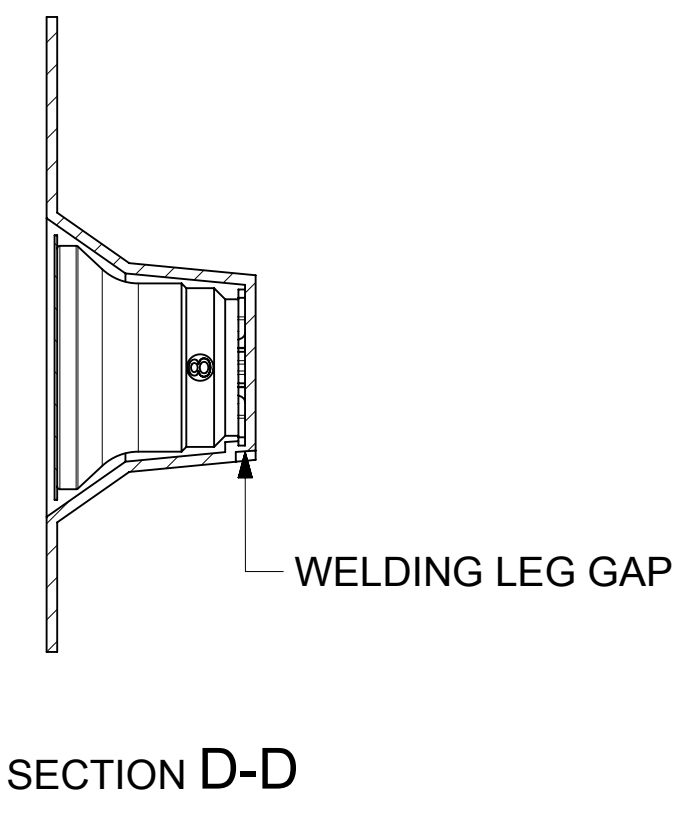
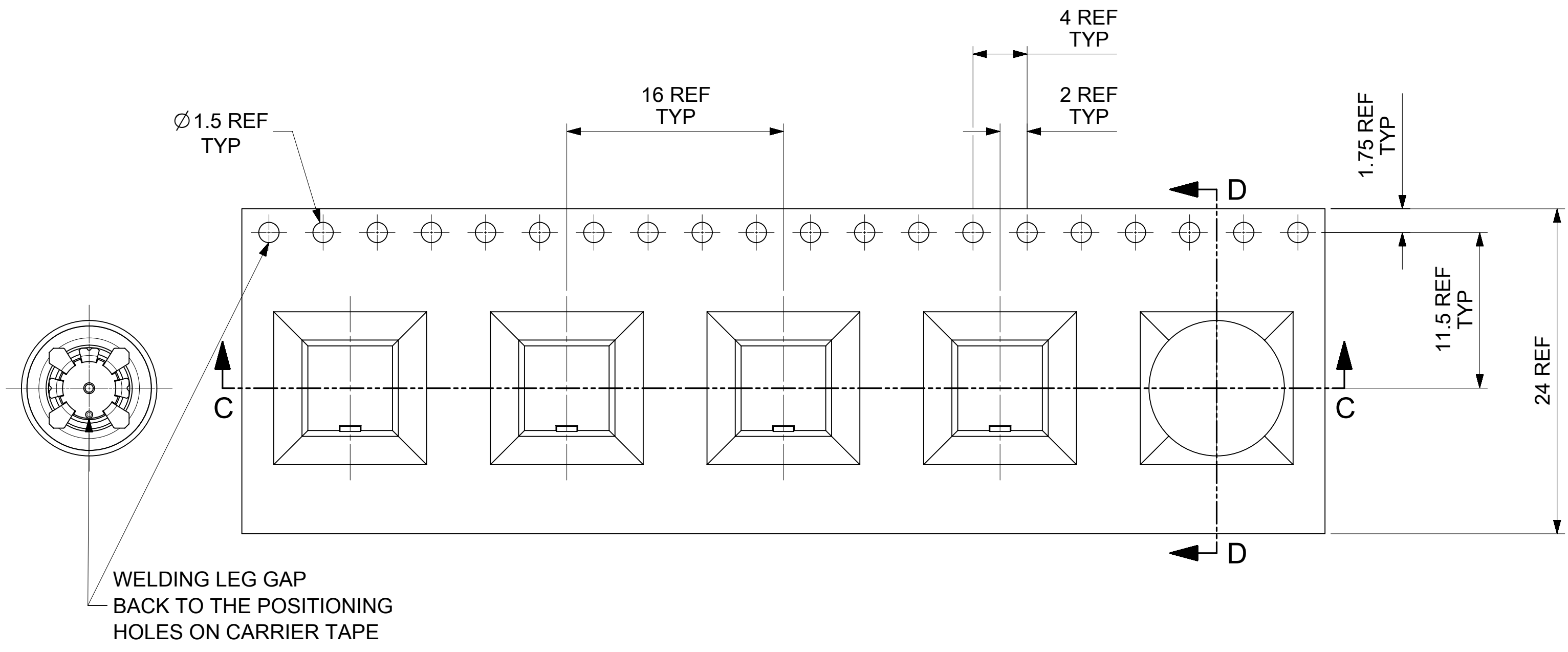

THIS DRAWING CONTAINS INFORMATION THAT IS PROPRIETARY TO MOLEX ELECTRONIC TECHNOLOGIES, LLC AND SHOULD NOT BE USED WITHOUT WRITTEN PERMISSION									
DIMENSION UNITS		SCALE		CURRENT REV DESC: UPDATE VIEWS FOR PACKING DIRECTION & RECOMMENDED PCB LAYOUT ; ADD PLATING THICKNESS PER EWR #12293-P (PCN #513327)				molex	
mm		NTS							
GENERAL TOLERANCES (UNLESS SPECIFIED)				EC NO: 737826				SMP-MAX EVO II PLUG SLIDE TYPE PCB SMT EWR-12293	
ANGULAR TOL ± °				DRWN: RYEH 2022/10/26					
4 PLACES ±				CHK'D: YCHENG 2023/02/09				PRODUCT CUSTOMER DRAWING	
3 PLACES ±				APPR: YCHENG 2023/02/09					
2 PLACES ± 0.13				INITIAL REVISION:				DOCUMENT NUMBER	
1 PLACE ± 0.25				DRWN: RYEH 2018/07/20				734206220	
0 PLACES ± 0.38				APPR: YCHENG 2020/07/08				PSD 000 A5	
DRAFT WHERE APPLICABLE MUST REMAIN WITHIN DIMENSIONS				THIRD ANGLE PROJECTION		DRAWING		MATERIAL NUMBER	
						C-SIZE		SEE TABLE	
				SERIES		CUSTOMER		SHEET NUMBER	
				73420				2 OF 3	

DOCUMENT STATUS	P1	RELEASE DATE	2023/02/09	02:36:15
-----------------	----	--------------	------------	----------

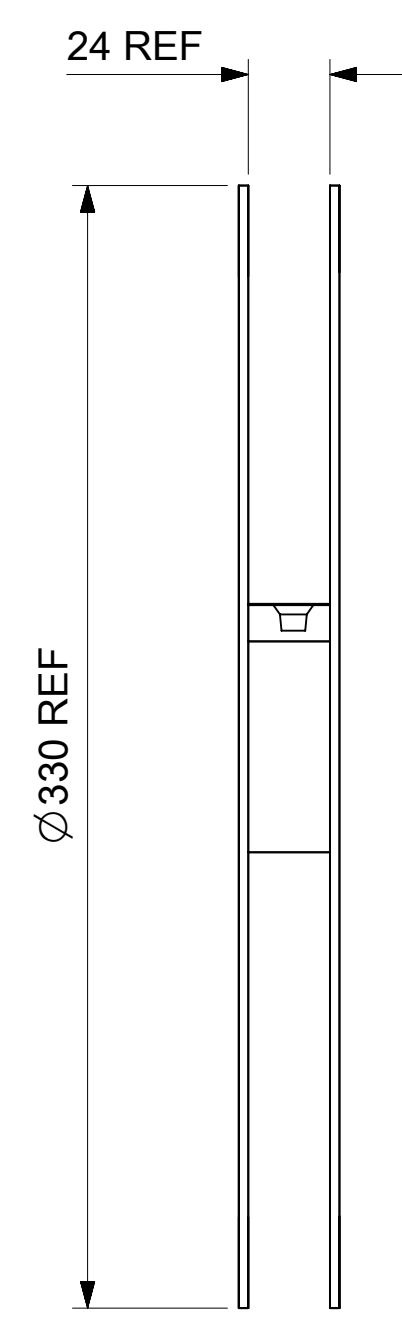

LABEL:
 -ORDER NUMBER
 -QUANTITY
 -PART NUMBER
 -LOT NUMBER

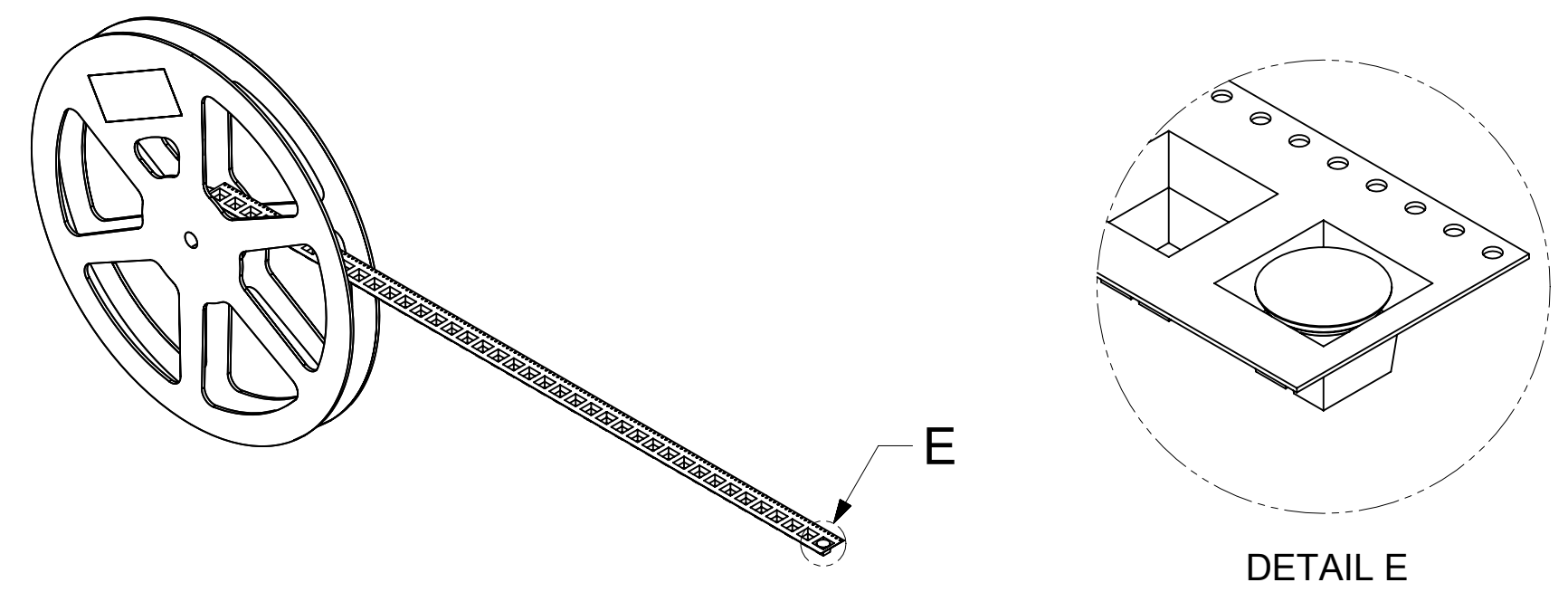
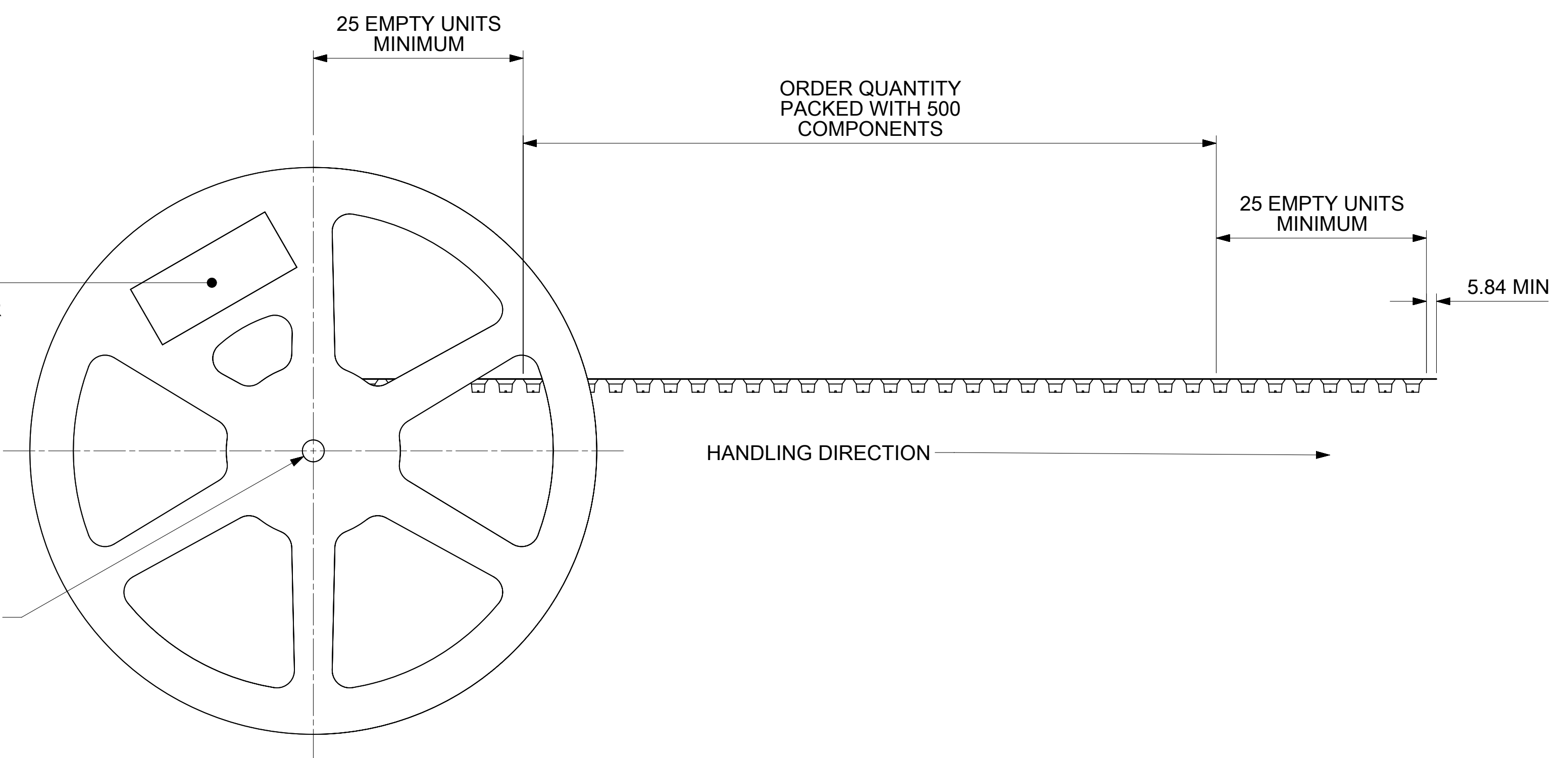

THIS DRAWING CONTAINS INFORMATION THAT IS PROPRIETARY TO MOLEX ELECTRONIC TECHNOLOGIES, LLC AND SHOULD NOT BE USED WITHOUT WRITTEN PERMISSION									
DIMENSION UNITS		SCALE		CURRENT REV DESC: UPDATE VIEWS FOR PACKING DIRECTION & RECOMMENDED PCB LAYOUT ; ADD PLATING THICKNESS PER EWR #12293-P (PCN #513327)				molex	
mm		NTS							
GENERAL TOLERANCES (UNLESS SPECIFIED)				EC NO: 737826				SMP-MAX EVO II PLUG SLIDE TYPE PCB SMT EWR-12293	
ANGULAR TOL ± °				DRWN: RYEH 2022/10/26					
4 PLACES ±				CHK'D: YCHENG 2023/02/09					
3 PLACES ±				APPR: YCHENG 2023/02/09				PRODUCT CUSTOMER DRAWING	
2 PLACES ± 0.13				INITIAL REVISION:					
1 PLACE ± 0.25				DRWN: RYEH 2018/07/20				DOCUMENT NUMBER	
0 PLACES ± 0.38				APPR: YCHENG 2020/07/08				734206220	
DRAFT WHERE APPLICABLE MUST REMAIN WITHIN DIMENSIONS				THIRD ANGLE PROJECTION		DRAWING		SERIES	
						C-SIZE		73420	
				MATERIAL NUMBER		CUSTOMER		SHEET NUMBER	
				SEE TABLE				3 OF 3	