



FAST CMOS BUFFER/CLOCK DRIVER

IDT49FCT805/A

FEATURES:

- 0.5 MICRON CMOS Technology
- Guaranteed low skew < 700ps (max.)
- Low duty cycle distortion < 1ns (max.)
- Low CMOS power levels
- TTL compatible inputs and outputs
- Rail-to-rail output voltage swing
- High drive: -24mA I_{OH} , +64mA I_{OL}
- Two independent output banks with 3-state control
- 1:5 fanout per bank
- "Heartbeat" monitor output
- Available in SSOP and SOIC packages

NOTE: EOL for non-green parts to occur on 5/13/10 per PDNU-09-01

DESCRIPTION:

The 49FCT805 is a non-inverting buffer/clock driver built using advanced dual metal CMOS technology. Each bank consists of two banks of drivers. Each bank drives five output buffers from a standard TTL compatible input. These devices feature a "heart-beat" monitor for diagnostics and PLL driving. The MON output is identical to all other outputs and complies with the output specifications in this document.

The 49FCT805 offers low capacitance inputs and hysteresis. Rail-to-rail output swing improves noise margin and allows easy interface with CMOS inputs.

FUNCTIONAL BLOCK DIAGRAM

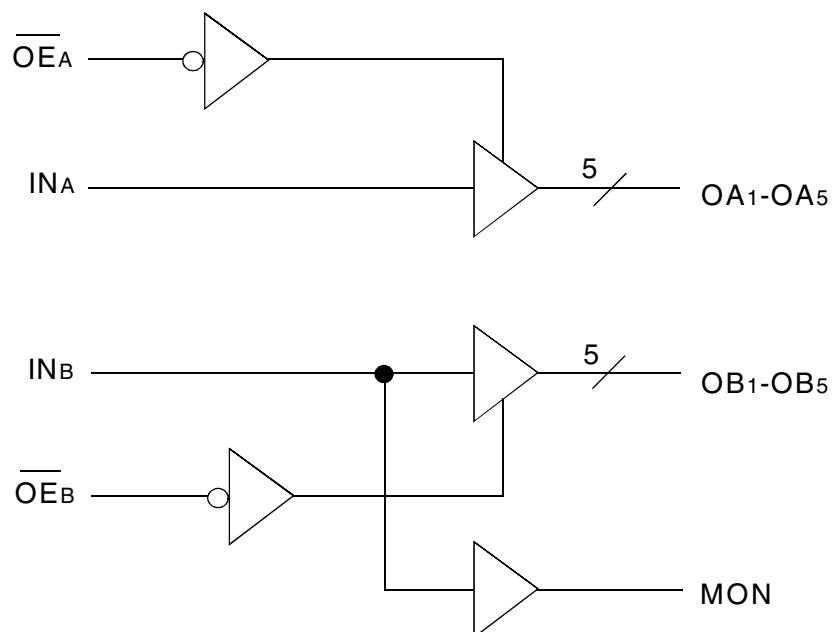

PIN CONFIGURATION

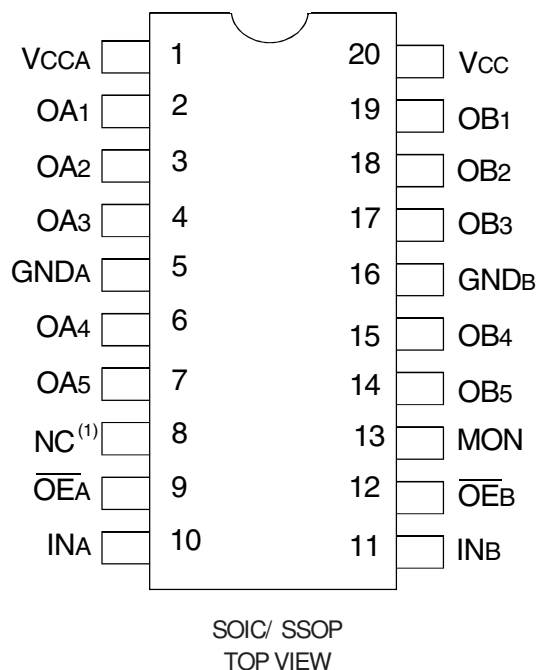

NOTE:

1. Pin 8 is not internally connected on devices with a "K" prefix in the date code. On older devices, pin 8 is internally connected to GND. To insure compatibility with all products, pin 8 should be connected to GND at the board level.

ABSOLUTE MAXIMUM RATINGS⁽¹⁾

Symbol	Description	Max	Unit
V _{TERM} ⁽²⁾	Terminal Voltage with Respect to GND	-0.5 to +7	V
V _{TERM} ⁽³⁾	Terminal Voltage with Respect to GND	-0.5 to V _{CC} +0.5	V
T _{STG}	Storage Temperature	-65 to +150	°C
I _{OUT}	DC Output Current	-60 to +60	mA

NOTES:

1. Stresses greater than those listed under ABSOLUTE MAXIMUM RATINGS may cause permanent damage to the device. This is a stress rating only and functional operation of the device at these or any other conditions above those indicated in the operational sections of this specification is not implied. Exposure to absolute maximum rating conditions for extended periods may affect reliability.
2. Input and V_{CC} terminals.
3. Output and I/O terminals.

CAPACITANCE (T_A = +25°C, f = 1.0MHz)

Symbol	Parameter ⁽¹⁾	Conditions	Typ.	Max.	Unit
C _{IN}	Input Capacitance	V _{IN} = 0V	4.5	6	pF
C _{OUT}	Output Capacitance	V _{OUT} = 0V	5.5	8	pF

NOTE:

1. This parameter is measured at characterization but not tested.

PIN DESCRIPTION

Pin Names	Description
OE _A , OE _B	3-State Output Enable Inputs (Active LOW)
IN _A , IN _B	Clock Inputs
OA _n , OB _n	Clock Outputs
MON	Monitor Output

FUNCTION TABLE (1)

Inputs		Outputs	
OE _A , OE _B	IN _A , IN _B	OA _n , OB _n	MON
L	L	L	L
L	H	H	H
H	L	Z	L
H	H	Z	H

NOTE:

1. H = HIGH
L = LOW
Z = High-Impedance

DC ELECTRICAL CHARACTERISTICS OVER OPERATING RANGE

Following Conditions Apply Unless Otherwise Specified: $V_{LC} = 0.2V$; $V_{HC} = V_{CC} - 0.2V$

Commercial: $T_A = 0^\circ C$ to $+70^\circ C$, Industrial: $T_A = -40^\circ C$ to $+85^\circ C$, $V_{CC} = 5V \pm 5\%$

Symbol	Parameter	Test Conditions ⁽¹⁾		Min.	Typ. ⁽²⁾	Max.	Unit
V_{IH}	Input HIGH Level (Input pins)	Guaranteed Logic HIGH Level		2	—	—	V
V_{IL}	Input LOW Level (Input and I/O pins)	Guaranteed Logic LOW Level		—	—	0.8	V
I_{IH}	Input HIGH Current	$V_{CC} = \text{Max.}$	$V_I = 5.5V$	—	—	± 1	μA
I_{IL}	Input LOW Current	$V_{CC} = \text{Max.}$	$V_I = \text{GND}$	—	—	± 1	μA
I_{OZH}	Off State (Hi-Z) Output Current	$V_{CC} = \text{Max.}$	$V_O = V_{CC}$	—	—	± 1	μA
I_{OZL}			$V_O = \text{GND}$	—	—	± 1	
V_{IK}	Clamp Diode Voltage	$V_{CC} = \text{Min.}, I_{IN} = -18mA$		—	-0.7	-1.2	V
I_{OS}	Short Circuit Current	$V_{CC} = \text{Max.}, V_O = \text{GND}^{(3)}$		-60	-120	—	mA
V_{OH}	Output HIGH Voltage	$V_{CC} = 3V, V_{IN} = V_{LC} \text{ or } V_{HC}$ $V_{CC} = \text{Min.}$ $V_{IN} = V_{IH} \text{ or } V_{IL}$	$I_{OH} = -32\mu A$	V_{HC}	V_{CC}	—	V
			$I_{OH} = -300\mu A$	V_{HC}	V_{CC}	—	
			$I_{OH} = -15mA$	3.6	4.3	—	
			$I_{OH} = -24mA$	2.4	3.8	—	
V_{OL}	Output LOW Voltage	$V_{CC} = 3V, V_{IN} = V_{LC} \text{ or } V_{HC}$ $V_{CC} = \text{Min.}$ $V_{IN} = V_{IH} \text{ or } V_{IL}$	$I_{OL} = 300\mu A$	—	GND	V_{LC}	V
			$I_{OL} = 300mA$	—	GND	V_{LC}	
			$I_{OL} = 64mA$	—	0.3	0.55	
V_H	Input Hysteresis for all inputs	—		—	200	—	mV
I_{CC}	Quiescent Power Supply Current	$V_{CC} = \text{Max.}, V_{IN} = \text{GND} \text{ or } V_{CC}$		—	5	500	μA

NOTES:

1. For conditions shown as Max. or Min., use appropriate value specified under Electrical Characteristics for the applicable device type.
2. Typical values are at $V_{CC} = 5V, +25^\circ C$ ambient.
3. Not more than one output should be shorted at one time. Duration of the test should not exceed one second.

POWER SUPPLY CHARACTERISTICS

Symbol	Parameter	Test Conditions ⁽¹⁾		Min.	Typ. ⁽²⁾	Max.	Unit
ΔI_{CC}	Quiescent Power Supply Current TTL Inputs HIGH	V _{CC} = Max. V _{IN} = 3.4V ⁽³⁾		—	1	2.5	mA
I _{CCD}	Dynamic Power Supply Current ⁽⁴⁾	V _{CC} = Max. Outputs Open OEA = OEB = GND 50% Duty Cycle	V _{IN} = V _{CC} V _{IN} = GND	—	0.15	0.2	mA/MHz
I _C	Total Power Supply Current ⁽⁶⁾	V _{CC} = Max. Outputs Open f _o = 10MHz 50% Duty Cycle OEA = OEB = V _{CC} Mon. Output Toggling	V _{IN} = V _{CC} V _{IN} = GND	—	1.5	2.5	mA
			V _{IN} = 3.4V V _{IN} = GND	—	2	3.8	
		V _{CC} = Max. Outputs Open f _o = 2.5MHz 50% Duty Cycle OEA = OEB = GND Eleven Outputs Toggling	V _{IN} = V _{CC} V _{IN} = GND	—	4.1	6 ⁽⁵⁾	
			V _{IN} = 3.4V V _{IN} = GND	—	5.1	8.5 ⁽⁵⁾	

NOTES:

- For conditions shown as Max. or Min., use appropriate value specified under Electrical Characteristics for the applicable device type.
- Typical values are at V_{CC} = 5V, +25°C ambient.
- Per TTL driven input (V_{IN} = 3.4V); all other inputs at V_{CC} or GND.
- This parameter is not directly testable, but is derived for use in Total Power Supply calculations.
- Values for these conditions are examples of the I_C formula. These limits are guaranteed but not tested.
- I_C = I_{QUIESCENT} + I_{INPUTS} + I_{DYNAMIC}
 $I_C = I_{CC} + \Delta I_{CC} \cdot D_H \cdot N_T + I_{CCD} \cdot (f_o \cdot N_o)$
 I_{CC} = Quiescent Current (I_{CC1}, I_{CC2} and I_{CC3})
 ΔI_{CC} = Power Supply Current for a TTL High Input (V_{IN} = 3.4V)
 D_H = Duty Cycle for TTL Inputs High
 N_T = Number of TTL Inputs at D_H
 I_{CCD} = Dynamic Current Caused by an Input Transition Pair (HLH or LHL)
 f_o = Output Frequency
 N_o = Number of Outputs at f_o
 All currents are in milliamps and all frequencies are in megahertz.

SWITCHING CHARACTERISTICS OVER OPERATING RANGE⁽¹⁾

Symbol	Parameter	Conditions ⁽²⁾	FCT805		FCT805A		Unit
			Min.	Max.	Min.	Max.	
t _{PLH} t _{PHL}	Propagation Delay INA to OAn, INB to OBn	CL = 50pF RL = 500Ω	1.5	5.6	1.5	5.3	ns
t _R	Output Rise Time		—	1.5	—	1.5	ns
t _F	Output Fall Time		—	1.5	—	1.5	ns
t _{SK(O)}	Output skew: skew between outputs of all banks of same package (inputs tied together)		—	0.7	—	0.7	ns
t _{SK(P)}	Pulse skew: skew between opposite transitions of same output (t _{PHL} – t _{PLH})		—	1	—	1	ns
t _{SK(PP)}	Part-to-part skew: skew between outputs of different packages at same power supply voltage, temperature, package type and speed grade		—	1.5	—	1.5	ns
t _{PZL} t _{PZH}	Output Enable Time OEA to OAn, OEB to OBn		1.5	8	1.5	8	ns
t _{PLZ} t _{PHZ}	Output Disable Time OEA to OAn, OEB to OBn		1.5	7	1.5	7	ns

NOTES:

1. Propagation delay range indicated by Min. and Max. limit is due to V_{cc}, operating temperature and process parameters. These propagation delay limits do not imply skew.
2. See test circuits and waveforms.

TEST CIRCUITS AND WAVEFORMS

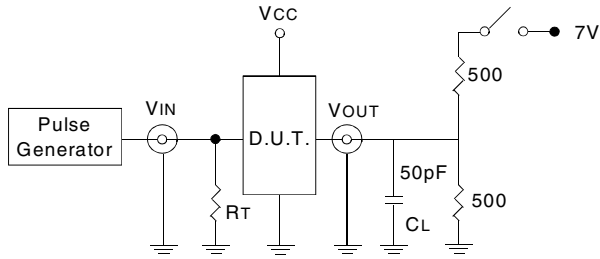

Test Circuits for All Outputs

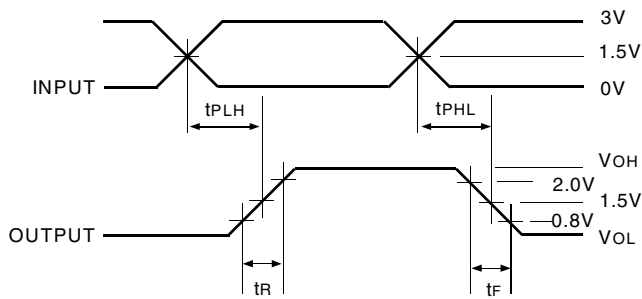

Package Delay

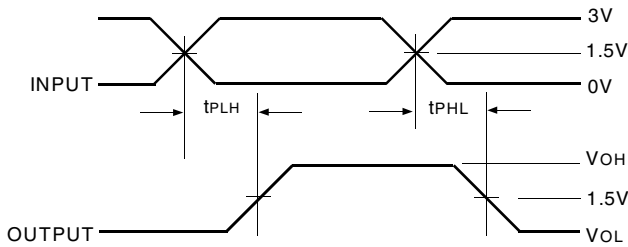

$$t_{SK}(p) = |t_{PHL} - t_{PLH}|$$

Pulse Skew - $t_{SK}(P)$

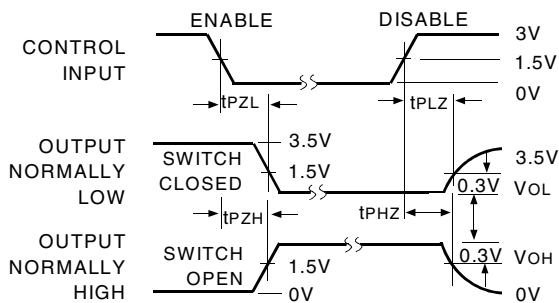

Enable and Disable Times

SWITCH POSITION

Test	Switch
Disable LOW Enable LOW	Closed
Disable HIGH Enable HIGH	GND

DEFINITIONS:

CL = Load capacitance: includes jig and probe capacitance.

RT = Termination resistance: should be equal to ZOUT of the Pulse Generator.

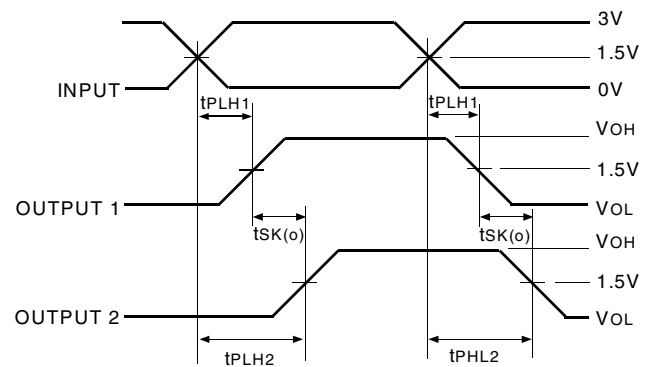

$$t_{SK}(o) = |t_{PLH2} - t_{PLH1}| \text{ or } |t_{PHL2} - t_{PHL1}|$$

Output Skew

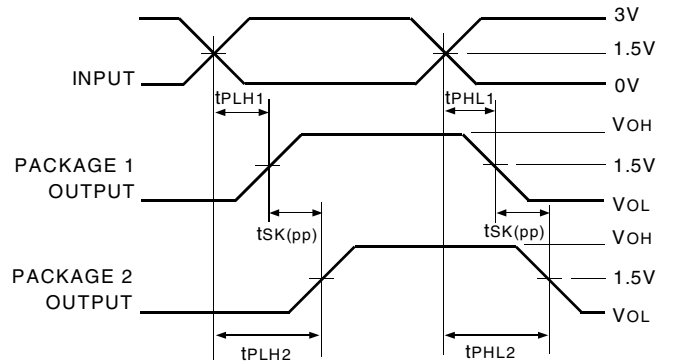

$$t_{SK}(pp) = |t_{PLH2} - t_{PLH1}| \text{ or } |t_{PHL2} - t_{PHL1}|$$

Part-to-Part Skew - $t_{SK}(PP)$

NOTE:

1. Package 1 and Package 2 are same device type and speed grade.

NOTES:

1. Diagram shown for input Control Enable-LOW and input Control Disable-HIGH
2. Pulse Generator for All Pulses: Rate $\leq 1.0\text{MHz}$; $t_r \leq 2.5\text{ns}$; $t_f \leq 2.5\text{ns}$

ORDERING INFORMATION

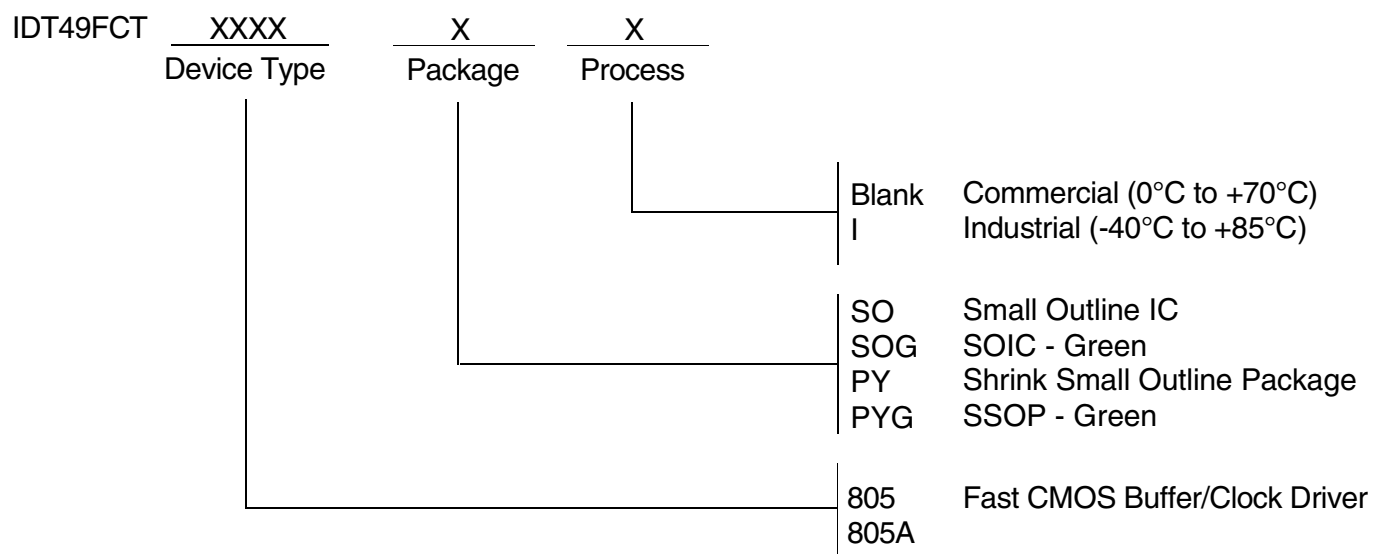

NOTE: EOL for non-green parts to occur on 5/13/10 per PDN U-09-01



CORPORATE HEADQUARTERS
6024 Silver Creek Valley Road
San Jose, CA 95138

for SALES:
800-345-7015 or 408-284-8200
fax: 408-284-2775
www.idt.com

for Tech Support:
clockhelp@idt.com