

4

3

2

1

THIS DRAWING IS UNPUBLISHED. RELEASED FOR PUBLICATION 20
 © COPYRIGHT 20 BY - ALL RIGHTS RESERVED.

LOC		DIST		REVISIONS			
P	LTR	DESCRIPTION		DATE	DWN	APVD	
	A	INITIAL RELEASE		14JUN2011	D.Z	S.Y	
	B	REVISED PER ECR-12-002341		06FEB2012	S.W	S.Y	
	C	REVISED PER ECR-15-017537		12JAN2016	D.Z	S.L	
	C1	REVISED PER ECR-16-012137		24AUG2016	D.Z	S.L	

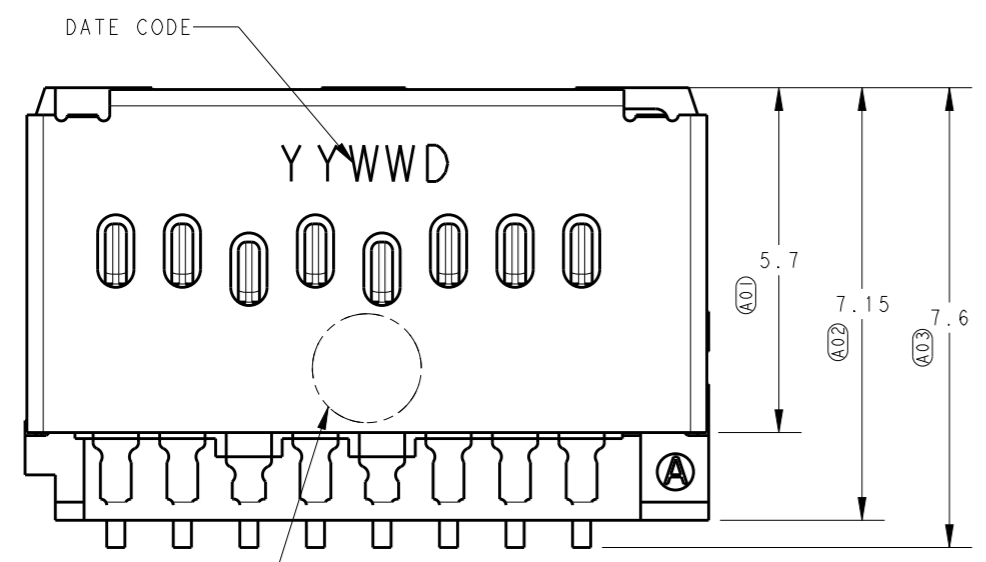

Mating End---0 ±0.20
 Card Detect Contact---0.88 ±0.20
 Contact 1,2,3,5,7,8---1.8 ±0.20
 Contact 4,6---2.4 ±0.20
 Mating Begin---5.55 ±0.20

CONTACTS MATING SEQUENCE

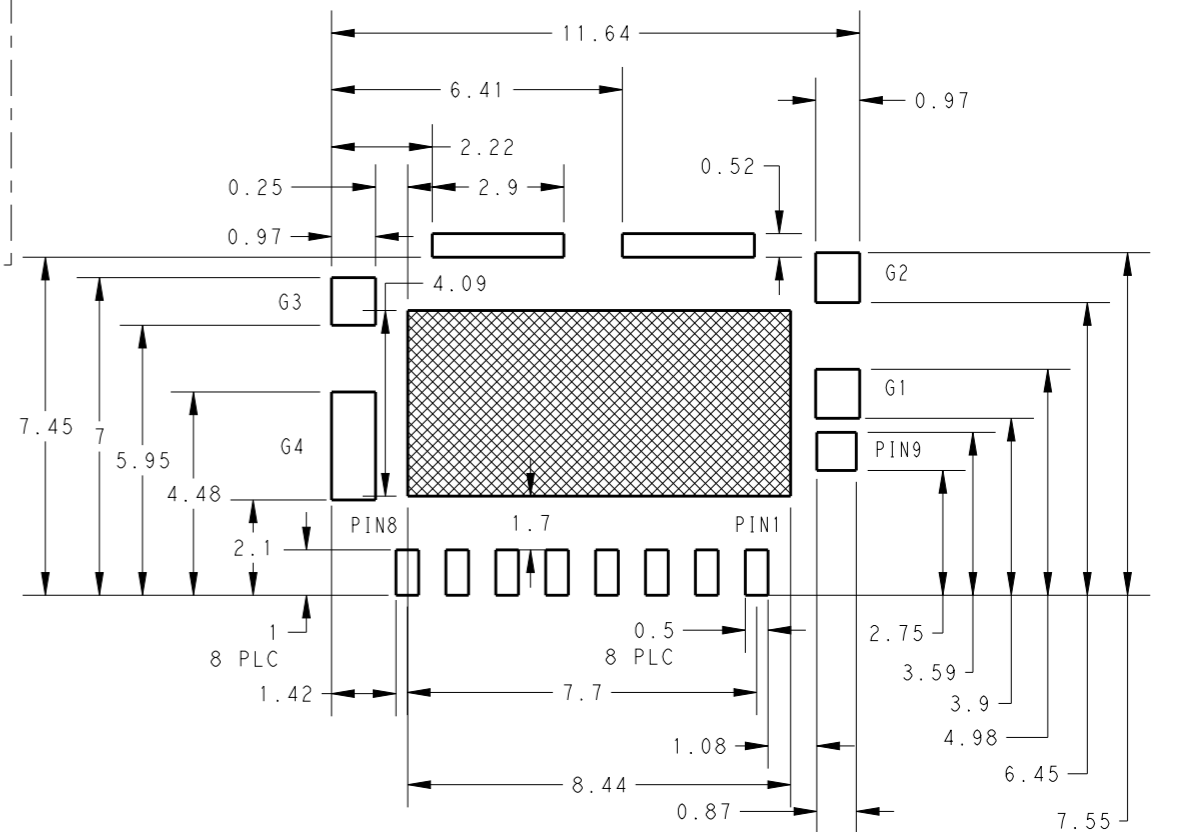
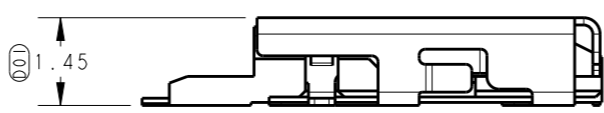
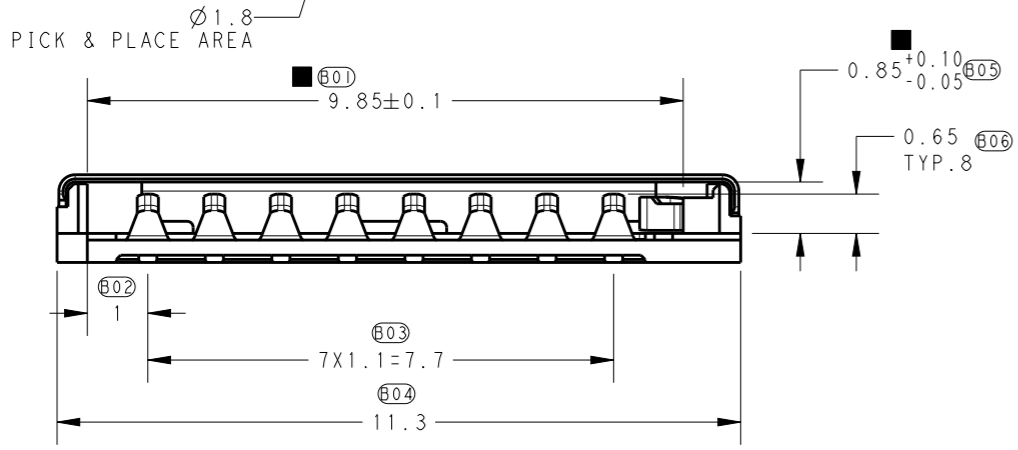

RECOMMENDED P.C.B. LAYOUT

(GENERAL TOLERANCE : ±0.05)
 ☒ PATTERN PROHIBITION AREA

- 1 MATERIAL
 HOUSING : LCP UL94V-0
 CONTACT : PHOSPHOR BRONZE
 SWITCH CONTACT : PHOSPHOR BRONZE
 SHELL : STAINLESS STEEL
- 2 FINISH
 CONTACT : Ni PL 0.0013 MIN. ALL OVER
 Au PL 0.0003 MIN. AT CONTACT AREA
 Au FLASH PL 0.00005-0.00013 AT SOLDERING AREA
 SWITCH CONTACT: Ni PL 0.0013 MIN. ALL OVER
 Au PL 0.0003 MIN. AT CONTACT AREA
 Au FLASH PL 0.00005-0.00013 AT SOLDERING AREA
 SHELL : Ni PL 0.0013 MIN. ALL OVER
 Au FLASH PL 0.00005-0.00013 AT SOLDERING AREA
- 3. COPLANARITY : 0.08MAX.
- 4. RECOMMENDED STENCIL THICKNESS 0.1mm MIN.
- : CRITICAL ITEMS.

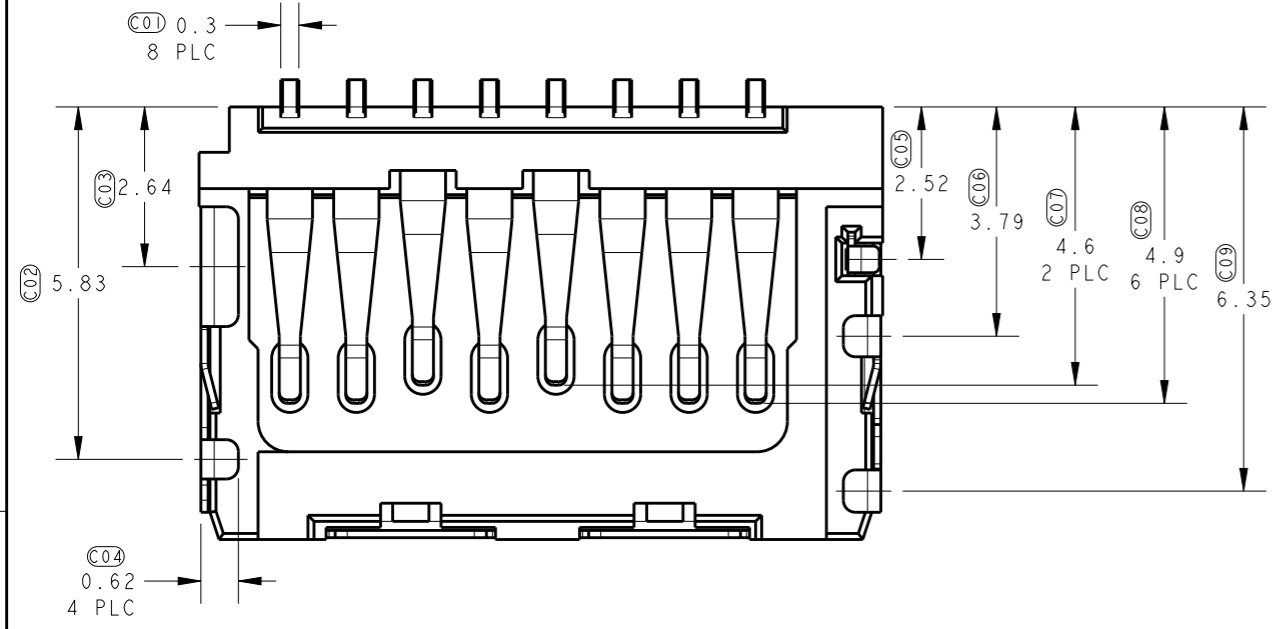



1932739-1: AS SHOWN

THIS DRAWING IS A CONTROLLED DOCUMENT.		DWN 13MAY2011 DANIEL ZHANG		TE Connectivity	
		CHK 13MAY2011 WENKE HE			
DIMENSIONS: mm		TOLERANCES UNLESS OTHERWISE SPECIFIED: ±0.2		NAME MicroSD SOCKET PUSH/PULL, LOW PROFILE TYPE	
		0 PLC ±		APVD 13MAY2011 STEVEN YAO	
		1 PLC ±0.5		PRODUCT SPEC 108-115017	
		2 PLC ±0.13		APPLICATION SPEC -	
		3 PLC ±0.013		WEIGHT -	
		4 PLC ±0.0001		SIZE A300779	
		ANGLES ±		CAGE CODE C-1932739	
MATERIAL 1		FINISH 2		DRAWING NO 1932739	
		CUSTOMER DRAWING		RESTRICTED TO -	
		SCALE 5:1		SHEET 1 OF 2	
				REV C1	

THIS DRAWING IS UNPUBLISHED. RELEASED FOR PUBLICATION 20
 © COPYRIGHT 20 BY - ALL RIGHTS RESERVED.

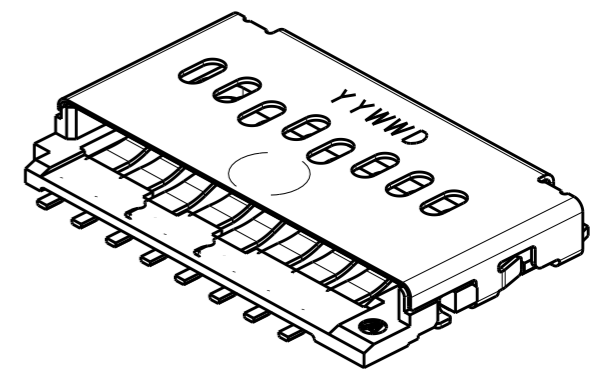
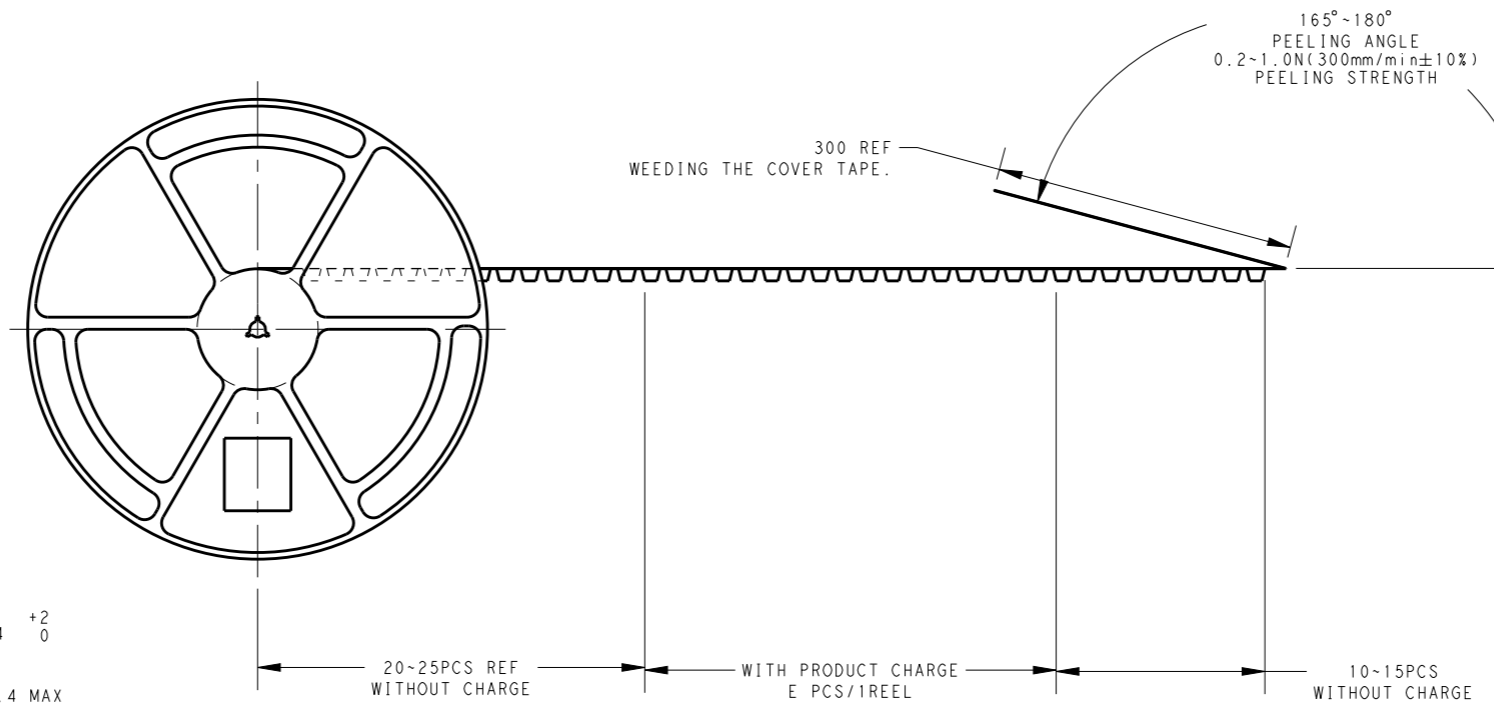
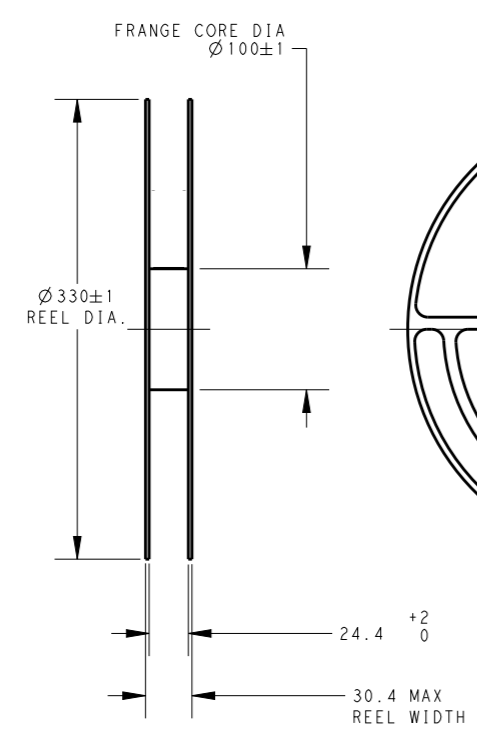
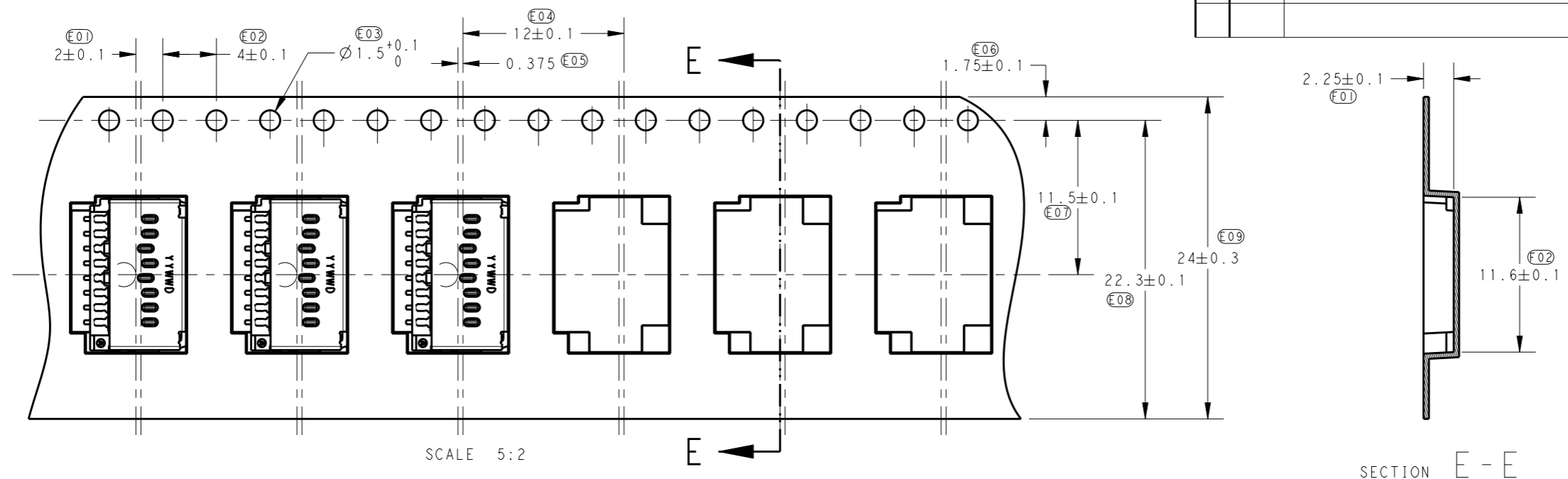
LOC		DIST		REVISIONS			
P	LTR	DESCRIPTION	DATE	DWN	APVD		
-	-	SEE SHEET 1	-	-	-		



THIS DRAWING IS A CONTROLLED DOCUMENT.		DWN DANIEL ZHANG 13MAY2011	 TE Connectivity	
DIMENSIONS: mm		CHK WENKE HE 13MAY2011		
TOLERANCES UNLESS OTHERWISE SPECIFIED:		APVD STEVEN YAO 13MAY2011	NAME MicroSD SOCKET PUSH/PULL, LOW PROFILE TYPE	
0 PLC ±- 1 PLC ±0.5 2 PLC ±0.13 3 PLC ±0.013 4 PLC ±0.0001 ANGLES ±-		PRODUCT SPEC -	RESTRICTED TO -	
MATERIAL -		FINISH -	APPLICATION SPEC -	SIZE A3
		WEIGHT -	WEIGHT -	CAGE CODE 00779
				DRAWING NO C-1932739
				SCALE 5:1
				SHEET 2 OF 2
				REV C1
				CUSTOMER DRAWING