

THIS DRAWING IS UNPUBLISHED. RELEASED FOR PUBLICATION  
 © COPYRIGHT - By - ALL RIGHTS RESERVED.

LOC		DIST		REVISIONS			
P	LTR	DESCRIPTION		DATE	DWN	APVD	
CM	0	D2	REVISED PER ECR-12-010267	05JUN12	JR	TM	

- 1 0.00076 [.000030] MIN GOLD IN LOCALIZED GOLD PLATE AREA AND 0.00254 [.000100] MIN BRIGHT TIN-LEAD IN LOCALIZED TIN-LEAD PLATE AREA OVER 0.0013 [.000050] MIN NICKEL.
- 2 WIRE RANGE: 0.12 - 0.4MM<sup>2</sup> (26-22 AWG).
- 3 INSULATION RANGE: 1.19-1.75[.047-.069] DIA.
- 4 DIMENSIONS IN BRACKETS ARE IN INCHES.
- 5 0.00076 [.000030] MIN GOLD IN LOCALIZED GOLD PLATE AREA AND 0.00254 [.000100] MIN MATTE TIN IN LOCALIZED TIN PLATE AREA OVER 0.0013 [.000050] MIN NICKEL.

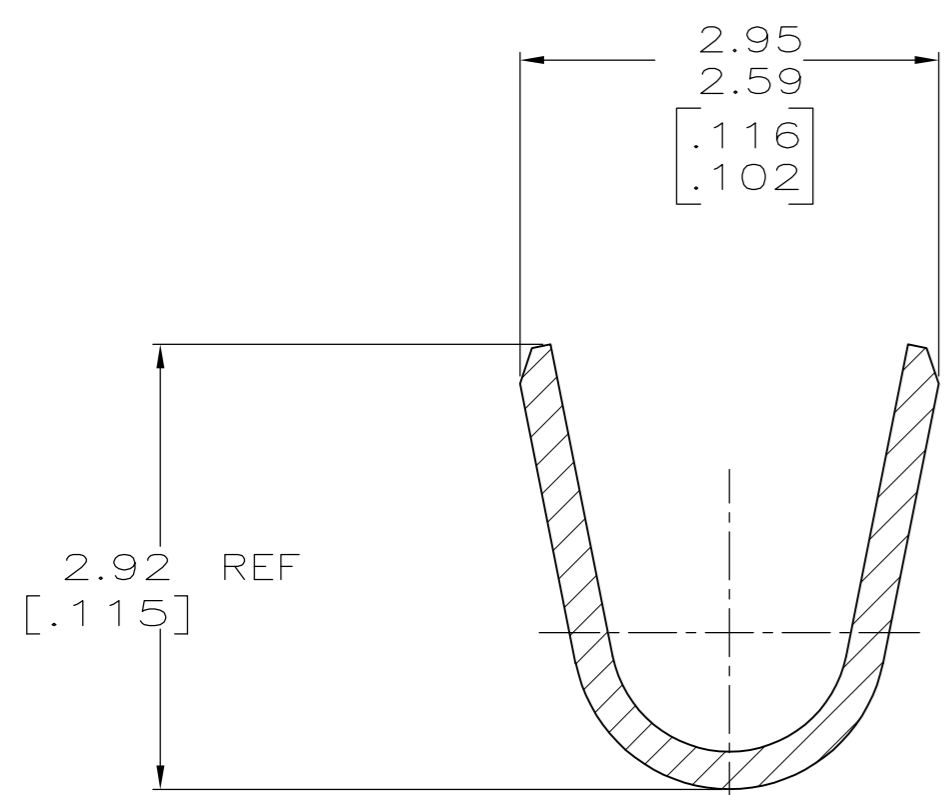
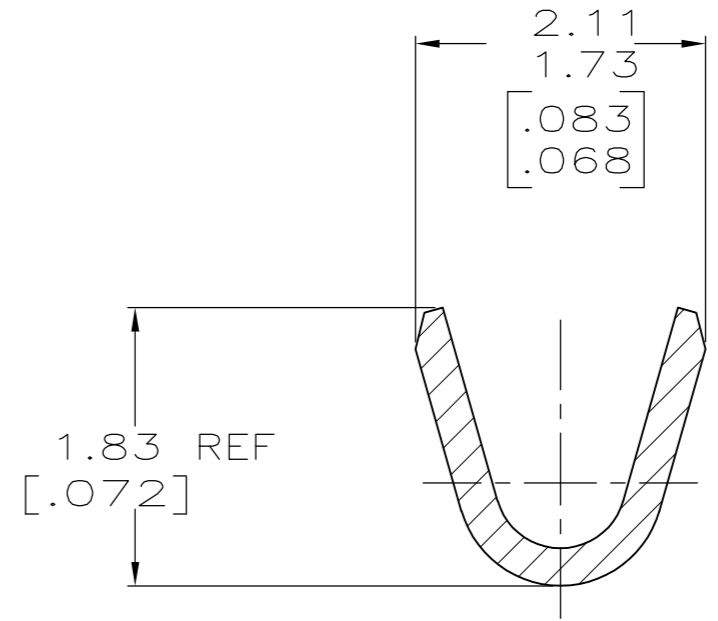
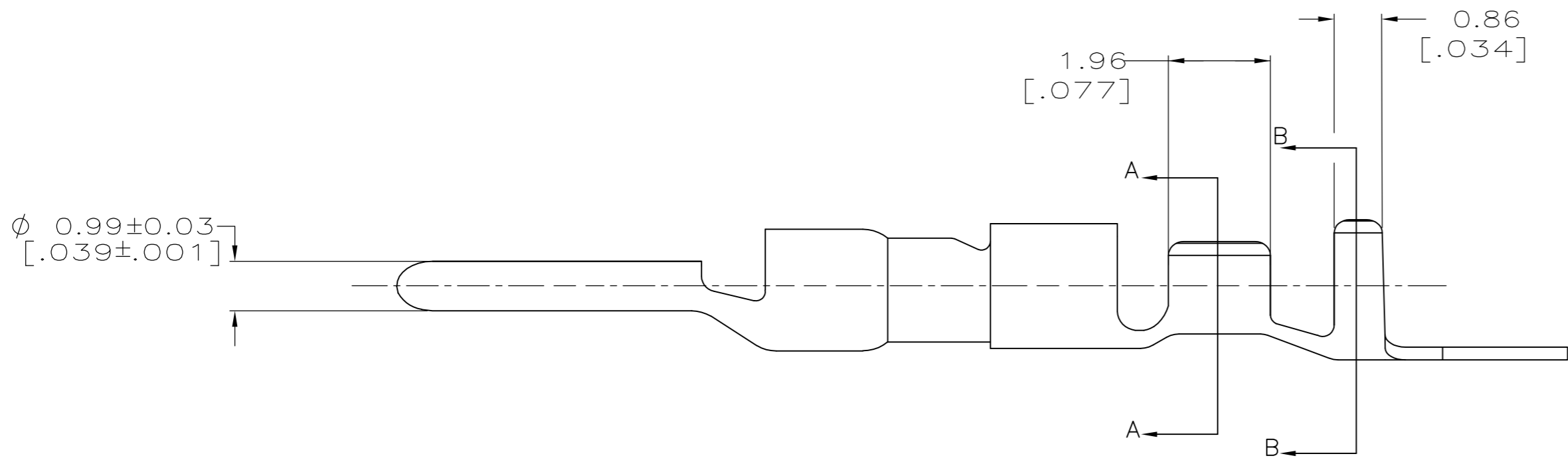
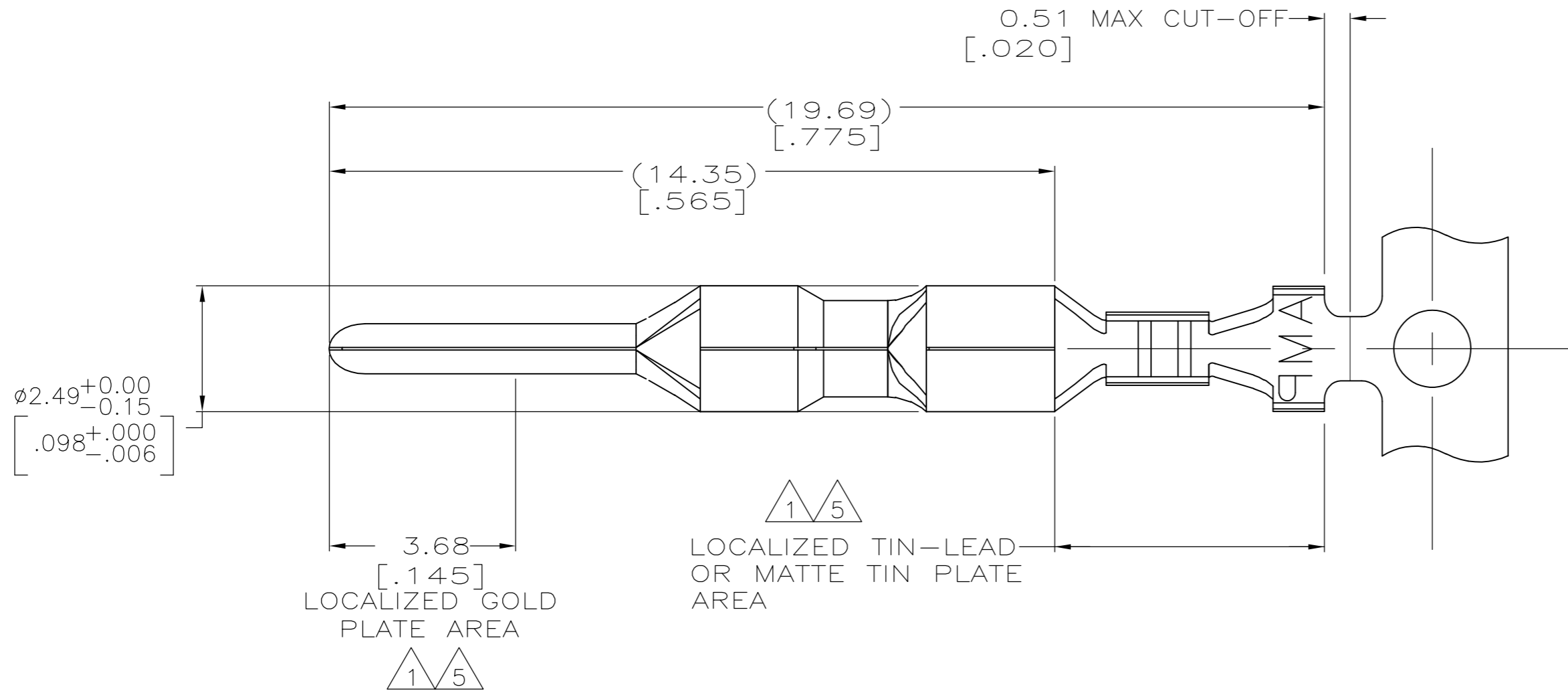

5	0.25[.010] BRASS	1-794218-0
1	0.25[.010] BRASS	794218-3
PRE-TIN	0.25[.010] BRASS	794218-1
FINISH	MATERIAL	PART NUMBER

THIS DRAWING IS A CONTROLLED DOCUMENT.		DWN R. VESTAL 1-15-97	TE Connectivity	
DIMENSIONS: mm [INCHES]		CHK R. SWING 1-15-97	PIN, MINI UNIVERSAL MATE-N-LOK 2	
TOLERANCES UNLESS OTHERWISE SPECIFIED:		APVD -	RESTRICTED TO	
0 PLC ± -		PRODUCT SPEC -	-	
1 PLC ± -		APPLICATION SPEC -	-	
2 PLC ± -		WEIGHT -	SIZE A2	CAGE CODE 00779
3 PLC ± 0.15 [.006]		FINISH SEE TABLE	DRAWING NO C=794218	REV D2
4 PLC ± -		MATERIAL SEE TABLE	SCALE 10:1	SHEET 1 of 1
ANGLES ± -		CUSTOMER DRAWING		