

NOTES:

- FOR WAVESOLDERING (SOLDER BATH TEMPERATURE 240°C FOR 5 SEC. / AND SOLDER PREHEAT 120°C FOR 120 SEC.)
- METALSHELLS: COPPER ALLOY; min. 315µin TIN over 40-80µin NICKEL
- INSULATORS: PBT GF UL 94 V-0; BLACK
- SIGNAL CONTACTS: COPPER ALLOY; PLATING (SEE PART NO.):
 - PLEASE ADD C for 30µin HARD GOLD over min. 50µin NICKEL
 - PLEASE ADD B for 20µin HARD GOLD over min. 50µin NICKEL
 - PLEASE ADD A for GOLD FLASH over NICKEL (PREFERRED TYPE)
- METAL BRACKETS: ZINC DIE CAST; 300µin COPPER/40-120µin NICKEL/ 120-200µin TIN
- THREADED INSERTS: COPPER ALLOY; min. 200µin TIN over 80µin NICKEL
- HEXLOCKING SCREWS: STAINLESS STEEL
- FRAME: ZINC DIE CAST; NICKEL PLATED
- FIXING PLATE: PBT GF UL 94 V-0; BLACK
- O-RING: SILICON; BLUE
- RUBBER GASKET: TPE
- SEALING COMPOUND: PUR; BLUE
- P.C.B. HOLE DRILLINGS AND RECOMMENDED PANEL CUT-OUT ON SHEET 2
- RECOMMENDED TORQUE FOR MOUNTING SCREW 35Ncm (3.1 in.LB) / max.40Ncm (3.5 in.LB)
- CONNECTOR IS PART MARKED: **6HDD26P□Y99R20X CONEC ABC** (see note 4)

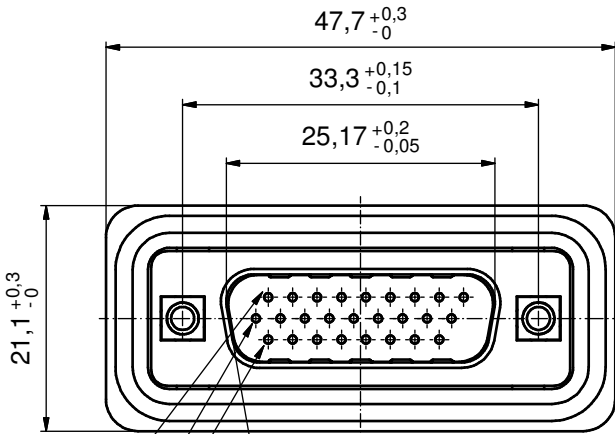

POS. 1
POS. 10
POS. 19

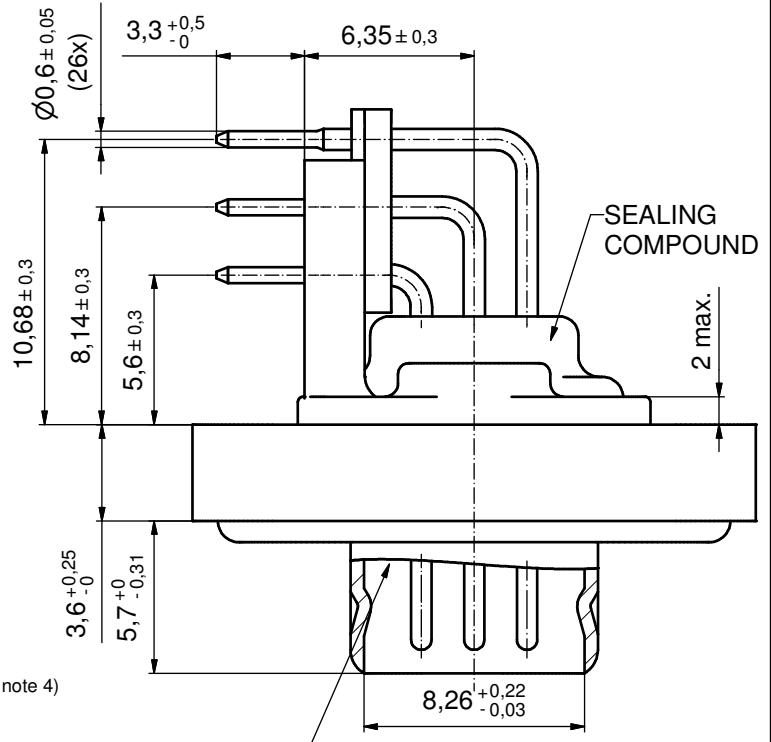
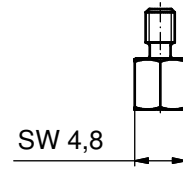
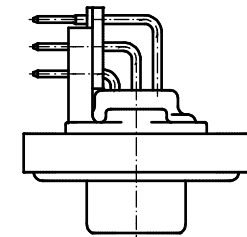
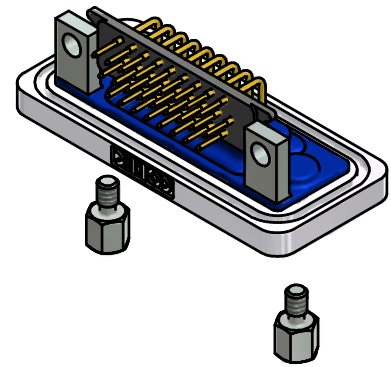
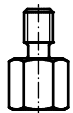
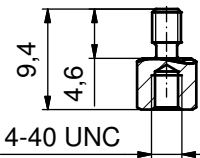
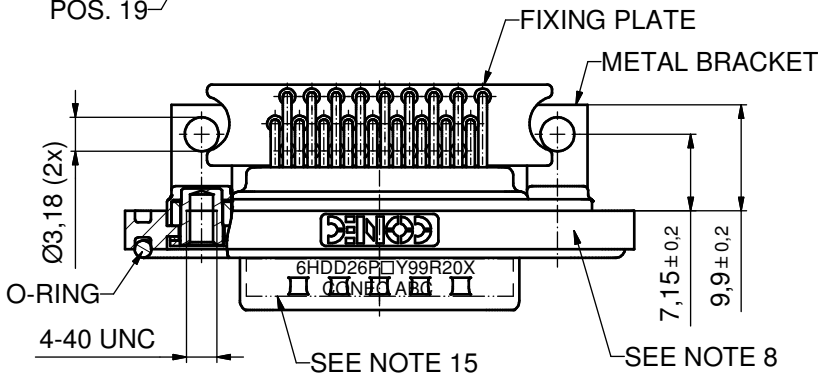

AT ALL TIMES WATER RESISTANT CONNECTORS NOT IN USE SHOULD BE COVERED WITH A CONEC WATERRESISTANT CAP OR WATERTIGHT HOOD.

Directive 2002/95/EC RoHS compliant

tolerance				dim. in mm		scale: 2:1 (5:1)	
				material: SEE NOTES		title: D-SUB HD MALE 90° 26pos. SOLDER PIN ANGLED threaded insert, metal bracket, fixing plate	
DO NOT ALTER CAD DRAWING BY HAND				date	name	dwg no: 15K1A1074	
				drawn 11.07.12	Henneboel	DIN-A3	
1 x b A4375 11.07.12 K.H.				appd. 11.07.12	Koch	sh: 1/2	
				norm		part no: 6HDD26P□Y99R20X (see note 4)	
rev. description date name				d-old 18K1A476/18K2A476		CONEC®	
				CONEC®		part no: 6HDD26P□Y99R20X (see note 4)	

P.C.B. HOLE DRILLINGS
(P.C.B. TOP SIDE)

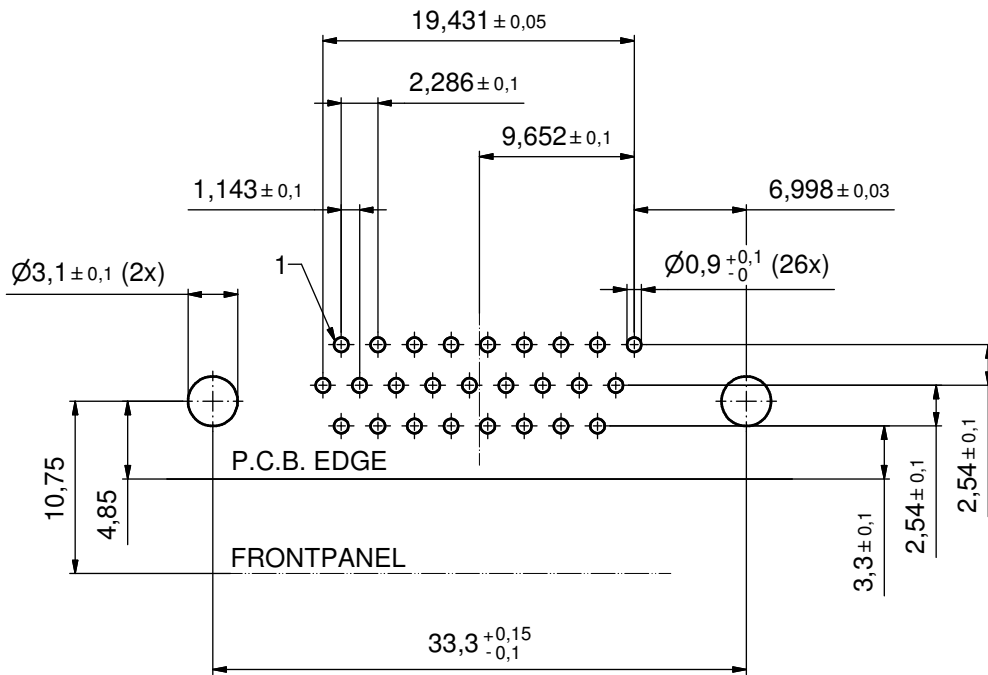

RECOMMENDED PANEL CUT-OUT

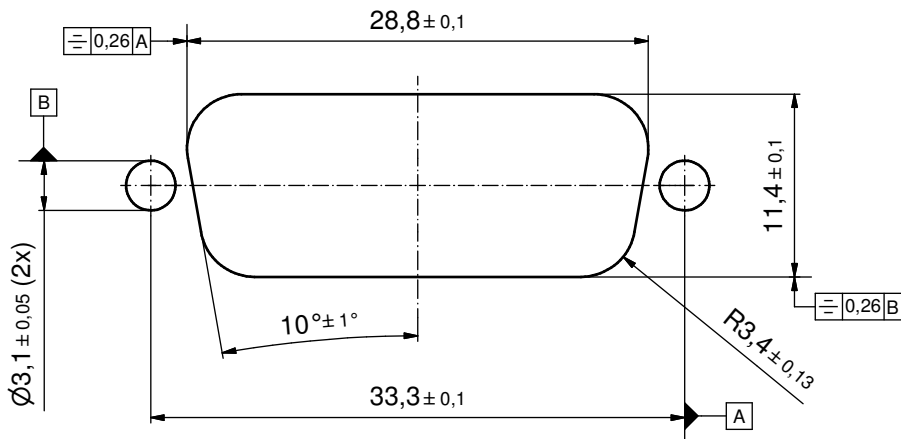

THIS DRAWING MAY NOT BE COPIED OR REPRODUCED IN ANY WAY, AND MAY NOT BE PASSED ON TO A THIRD PARTY WITHOUT WRITTEN PERMISSION. OWNERSHIP AND COPYRIGHT OF CONEC GmbH DO NOT ALTER CAD DRAWING BY HAND				tolerance		scale: 3:1
				date	name	material: SEE SHEET 1
	drawn	11.07.12	Henneboel	title:		
	appd.	11.07.12	Koch	P.C.B. HOLE DRILLINGS		
	norm			PANEL CUT-OUT		
d-old			D-SUB HD Male 26pos. Solder pin angled 90°			
a	Original		CONEC [®]			dwg no:
rev.	description	date				name
						part no: SEE SHEET 1