

High Performance, Low Noise Boost Converter

General Description

The RT9277A/B is a high performance, low noise, fixed frequency step up DC-DC Converter. The RT9277A/B converters input voltage ranging 2.5V to 5.5V into output voltage up to 16V. Current mode control with external compensation network makes it easy to stabilize the system and keep maximum flexibility. Soft start function minimizes impact on the input power system. Internal power MOSFET with very low $R_{DS(ON)}$ provides high efficiency. The RT9277A/B automatically transits from PWM to PSM (Pulse Skipping Mode) during light load condition further increasing efficiency. 640kHz and 1.2MHz operation frequency options provide flexibility of minimum output inductor size, maximum efficiency and low BOM cost.

The RT9277A/B also provides comprehensive protection functions such as UVLO, OCP and OTP.

Ordering Information

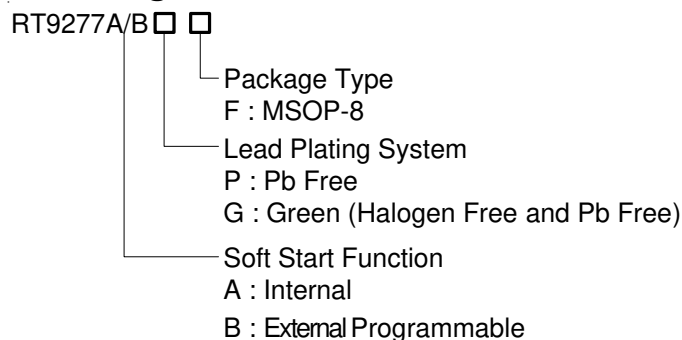

Note :

Richtek products are :

- ▶ RoHS compliant and compatible with the current requirements of IPC/JEDEC J-STD-020.
- ▶ Suitable for use in SnPb or Pb-free soldering processes.

Marking Information

For marking information, contact our sales representative directly or through a RichTek distributor located in your area.

Features

- **90% Efficiency**
- **V_{IN} Operating Range : 2.5V to 5.5V**
- **1.6A, 0.2Ω, 16V Internal Power MOSFET**
- **640kHz and 1.2MHz Operation Frequency**
- **External Compensation Network**
- **Internal/External Programmable Soft Start Function**
- **Small MSOP8 Package**
- **OCP and OTP Function are Included**
- **RoHS Compliant and 100% Lead (Pb)-Free**

Applications

- TFT LCD panel
- OLED Display
- PCMCIA Cards
- Portable Device

Pin Configurations

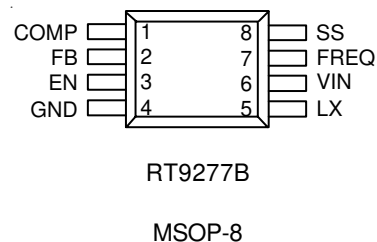
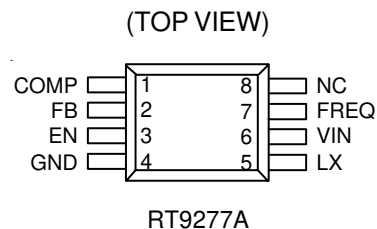

Typical Application Circuit

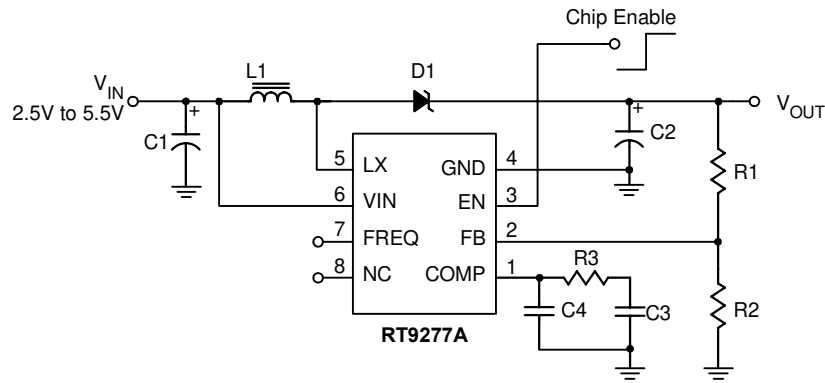

Figure 1

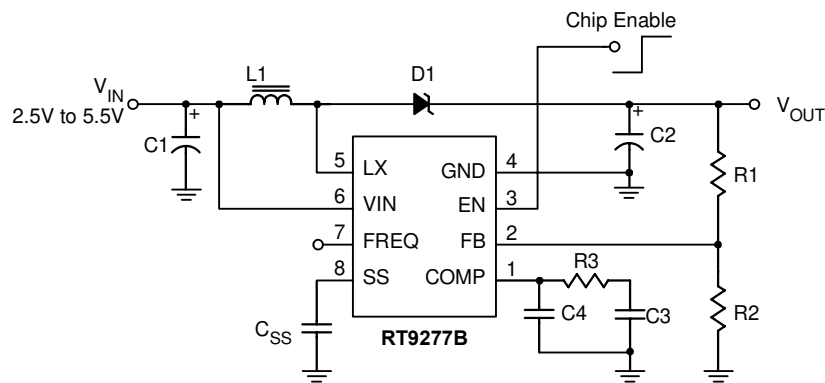
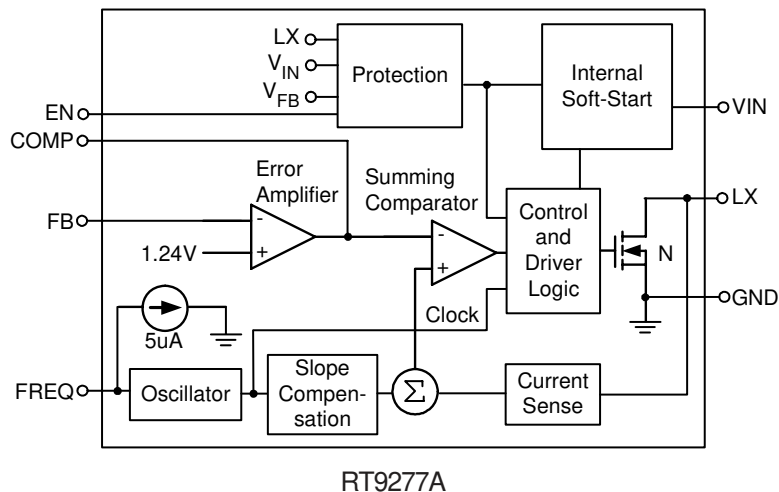

Figure 2

Table 1. Component Selection

Symbol (unit)	V _{IN} (V)	V _{OUT} (V)	F _{osc} (Hz)	C1 (uF)	L1 (uH)	C2 (uF)	R3 (kΩ)	C3 (pF)	C4 (pF)
Application 1	3.3	9	1.2M	10	4.7(TDK SLF6028)	33 (ceramic)	82	820	10
Application 2	3.3	12	1.2M	10	4.7(TDK SLF6028)	33 (ceramic)	180	680	22
Application 3	3.3	12	640K	10	10(TDK SLF6028)	33 (ceramic)	120	1200	22

Function Block Diagram



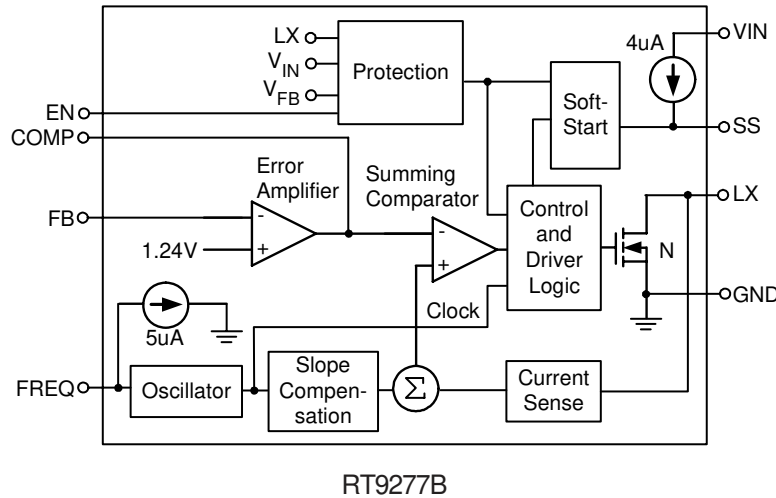

Operation

The RT9277A/B is a high efficiency step-up Boost converter with a fixed-frequency, current-mode PWM architecture. It performs fast transient response and low noise operation with appropriate component selection. The output voltage is regulated through a feedback control consisting of an error amplifier, a summing comparator, and several control signal generators (as shown in function block diagram). The feedback reference voltage is 1.24V. The error amplifier varies the COMP voltage by sensing the FB pin. The slope compensation signal summed with the current -sense signal will be compared with the COMP voltage through the summing comparator to determine the current trip point and duty cycle. When driving light loads, the RT9277A/B will perform the pulse-skipping mode to prevent overcharging the output voltage. In this mode, the switching frequency will be reduced to perform a higher efficiency.

Soft-Start

The RT9277B provides programmable soft-start function. When the EN pin is connected to high, a 4 μ A constant current is sourced to charge an external capacitor. The voltage rate of rise on the COMP pin is limited during the charging period, and so is the peak inductor current.

When the EN pin is connected to GND, the external capacitor will be discharged to ground for the next time soft-start.

Current Limitation

The switch current is monitored to limit the value not to exceed 1.6A typically. When the switch current reaches 1.6A, the output voltage will be pulled down to limit the total output power to protect the power switch and external components.

Shutdown

Connect the EN to GND to turn the RT9277A/B off and reduce the supply current to 0.1 μ A. In this operation, the output voltage is the value of V_{IN} to subtract the forward voltage of catch diode.

Frequency Selection

The switching frequency of RT9277A/B can be selected to operate at either 640kHz or 1.2MHz. When the FREQ pin is connected to GND for 640kHz operation, and connected to VIN for 1.2MHz operation. FREQ is preset to 640kHz operation for allowing the FREQ pin unconnected.

Functional Pin Description

Pin No.		Pin Name	Pin Function
RT9277A	RT9277B		
1	1	COMP	Compensation Pin for Error Amplifier. Connect a compensation network to ground. See the Component Selection Table for the loop compensation.
2	2	FB	Feedback Pin. Connect an external resistor-divider tap to FB. The typical reference voltage is 1.24V.
3	3	EN	Shutdown Control Input. Connect EN to GND to turn off the RT9277A/B.
4	4	GND	Ground
5	5	LX	Switch Pin. Connect the inductor and catch diode to LX pin. Widen and shorten the connected trace to minimize EMI.
6	6	VIN	Supply Pin. Place at least a 1 μ F ceramic capacitor close to RT9277A/B for bypassing noise.
7	7	FREQ	Frequency Select Pin. Oscillator frequency is 640kHz as FREQ connected to GND, and 1.2MHz as FREQ connected to VIN. A 5 μ A pull-down current is sinking on this pin.
--	8	SS	Soft-Start Control Pin. Connect a soft-start capacitor (C _{SS}) to this pin. A 4 μ A constant current charges the soft-start capacitor. When EN connected to GND, the soft-start capacitor is discharged. When EN connected to VIN high, the soft-start capacitor is charged to VIN. Leave floating for not using soft-start.
8	--	NC	No Connection

Absolute Maximum Ratings (Note 1)

- Supply Voltage (V_{IN}) ----- -0.3 to 6V
- LX to GND ----- -0.3V to 16V
- The other pins ----- -0.3V to 6V
- Power Dissipation, $P_D @ T_A = 70^\circ\text{C}$
 MSOP-8 ----- 625mW
- Package Thermal Resistance (Note 2)
 MSOP-8, θ_{JA} ----- 160°C/W
- Junction Temperature ----- 150°C
- Lead Temperature (Soldering, 10 sec.) ----- 260°C
- Storage Temperature Range ----- -65°C to 150°C
- ESD Susceptibility (Note 3)
 HBM (Human Body Mode) ----- 2kV
 MM (Machine Mode) ----- 200V

Recommended Operating Conditions (Note 4)

- Junction Temperature Range ----- -40°C to 125°C
- Ambient Temperature Range ----- -40°C to 85°C

Electrical Characteristics

($V_{IN} = 3\text{V}$, FREQ left floating, $T_A = 25^\circ\text{C}$, Unless Otherwise specification)

Parameter	Symbol	Test Conditions	Min	Typ	Max	Unit
System Supply Input						
Operation Voltage Range	V_{IN}		2.5	--	5.5	V
Under Voltage Lock Out	UVLO		1.9	2	2.1	V
Power On Reset Hysteresis			--	100	--	mV
Quiescent Current	I_Q	$V_{FB} = 1.3\text{V}$, No switching	--	250	350	μA
		$V_{FB} = 1.0\text{V}$, Switching, No load	--	2	5	mA
Shut Down Current	I_{SHDN}	EN = GND	--	--	1	μA
Soft start Current (RT9277B)	I_{SS}	$V_{SS} = 1.2\text{V}$	1.5	4	7	μA
Switching Regulator Oscillator						
Free Run Frequency	f_{OSC}	FREQ = GND	540	640	740	kHz
		FREQ = V_{IN}	--	1200	--	
Maximum Duty Cycle			82	90	96	%
Reference Voltage						
Feedback Reference Voltage	V_{REF}	$V_{COMP} = 1.24\text{V}$	1.222	1.24	1.258	V
Error Amplifier						
Transconductance	G_m		70	140	240	$\mu\Omega$
Voltage Gain	A_V		--	700	--	V/V

To be continued

Parameter	Symbol	Test Conditions	Min	Typ	Max	Unit
Feedback Voltage Line Regulation		$V_{COMP} = 1.24V,$ $2.5V < V_{IN} < 5.5V$	--	0.05	0.15	%/V
MOSFET						
On Resistance of MOSFET	$R_{DS(ON)}$		--	200	500	mΩ
Current Limitation			1.2	1.6	--	A
Enable Control Input						
Input Low Voltage	V_{IL}	$2.5V < V_{IN} < 5.5V$	--	--	$0.3 \times V_{IN}$	V
Input High Voltage	V_{IH}	$2.5V < V_{IN} < 5.5V$	$0.7 \times V_{IN}$	--	--	V
Hysteresis			--	0.1	--	V
Protection Function						
Over Temperature Protection			--	170	--	°C
Hysteresis			--	20	--	°C

Note 1. Stresses listed as the above "Absolute Maximum Ratings" may cause permanent damage to the device. These are for stress ratings. Functional operation of the device at these or any other conditions beyond those indicated in the operational sections of the specifications is not implied. Exposure to absolute maximum rating conditions for extended periods may remain possibility to affect device reliability.

Note 2. θ_{JA} is measured in the natural convection at $T_A = 25^\circ C$ on a low effective single layer thermal conductivity test board of JEDEC 51-3 thermal measurement standard.

Note 3. Devices are ESD sensitive. Handling precaution is recommended.

Note 4. The device is not guaranteed to function outside its operating conditions.

Typical Operating Characteristics

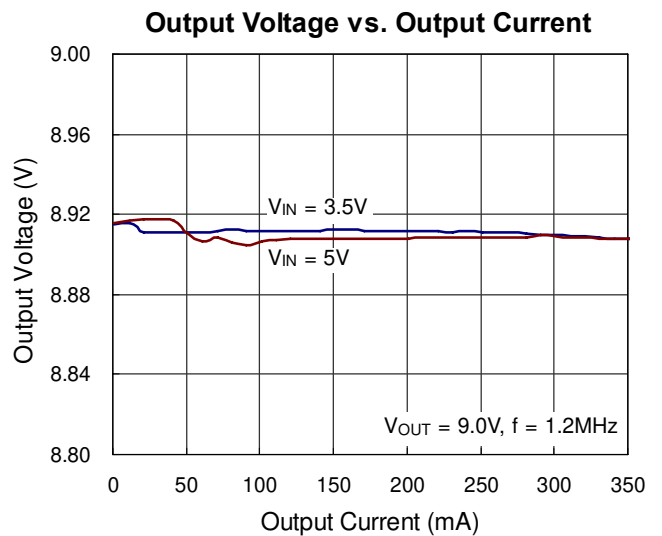
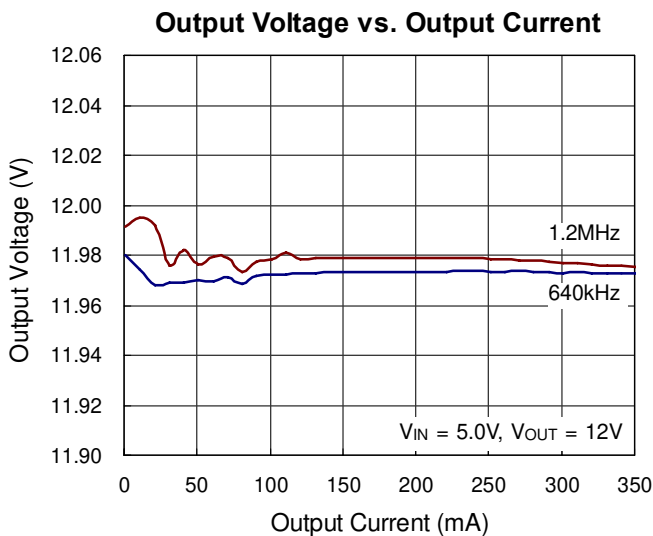
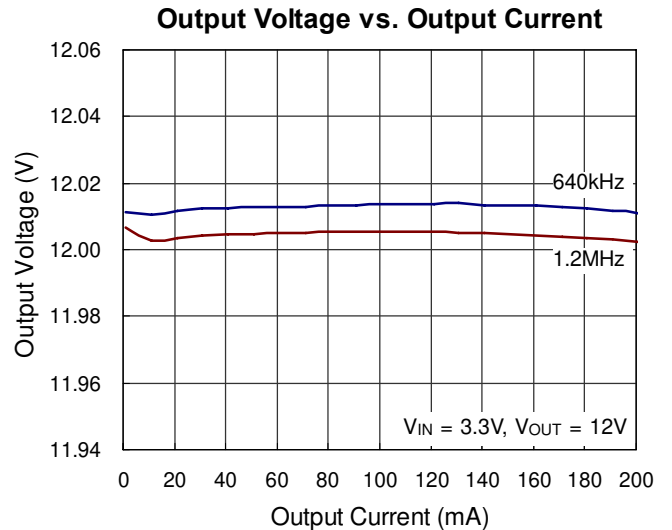
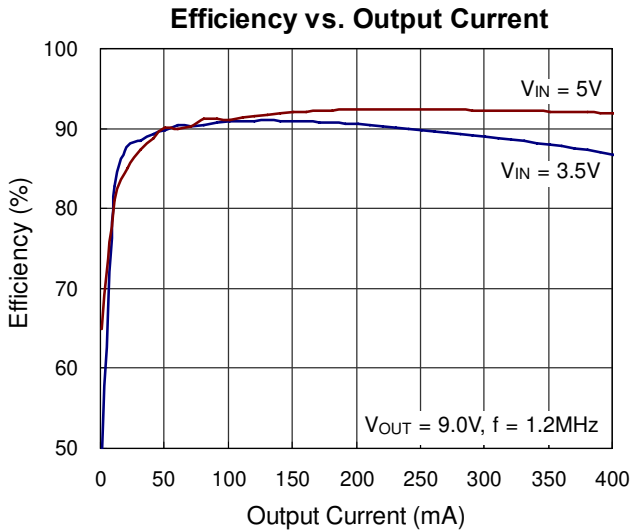
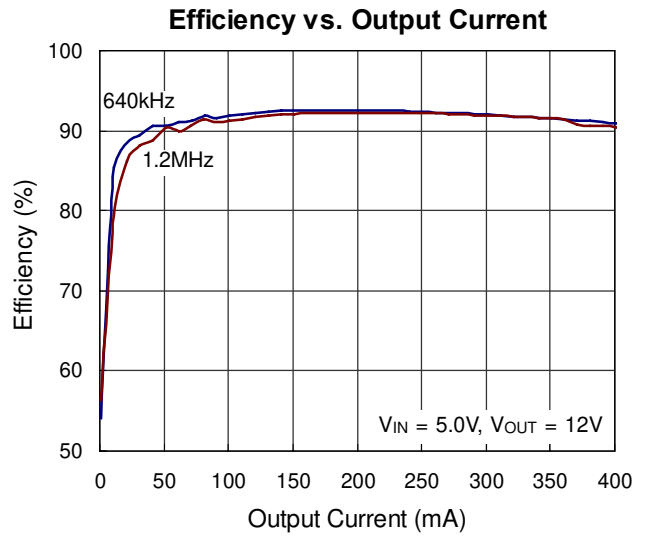
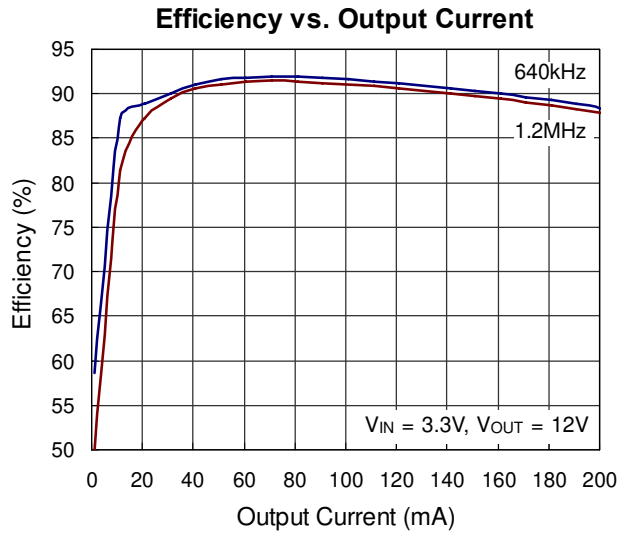

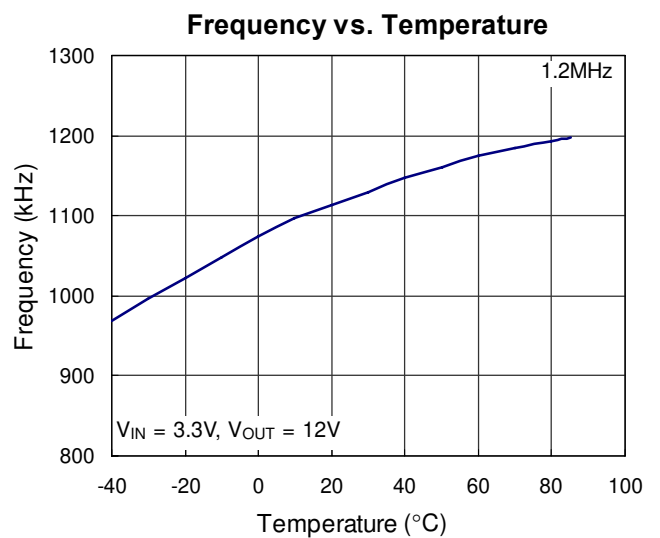
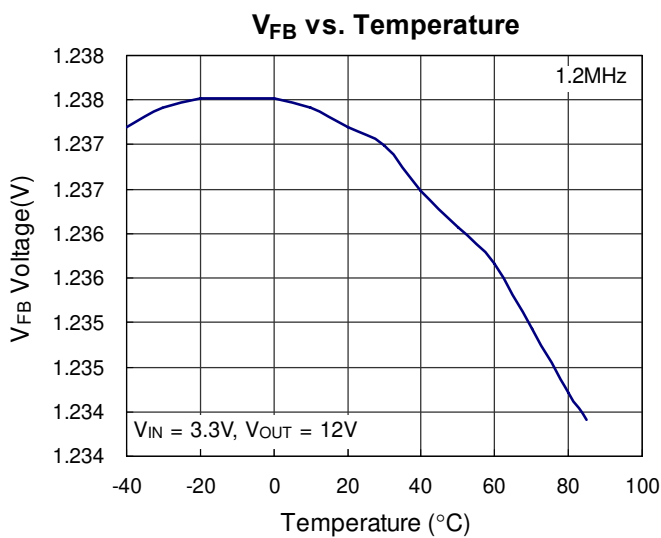
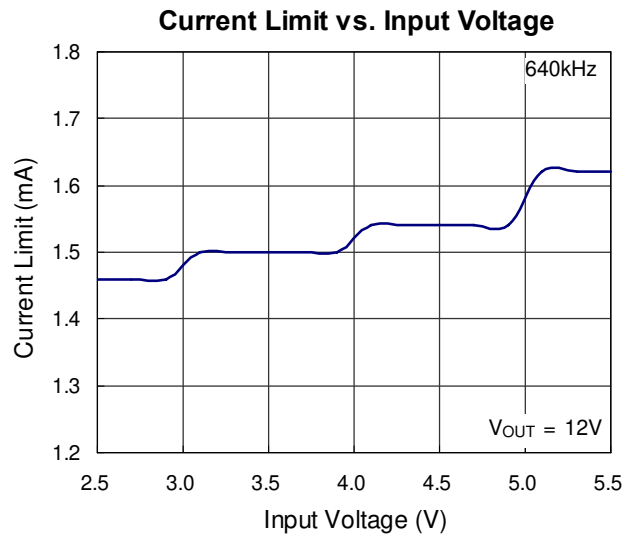
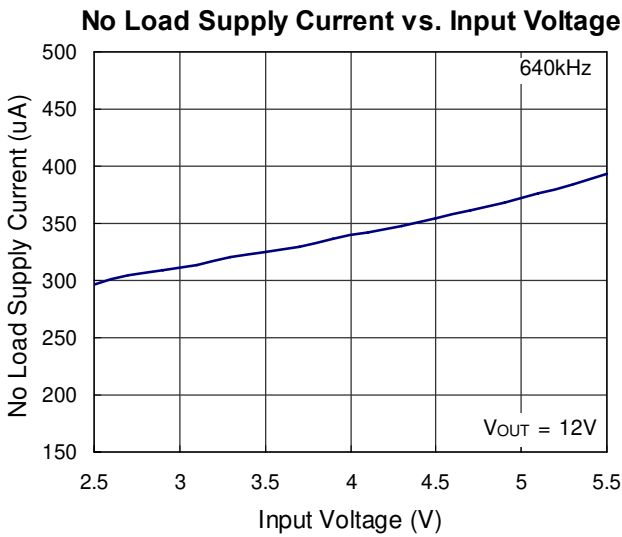
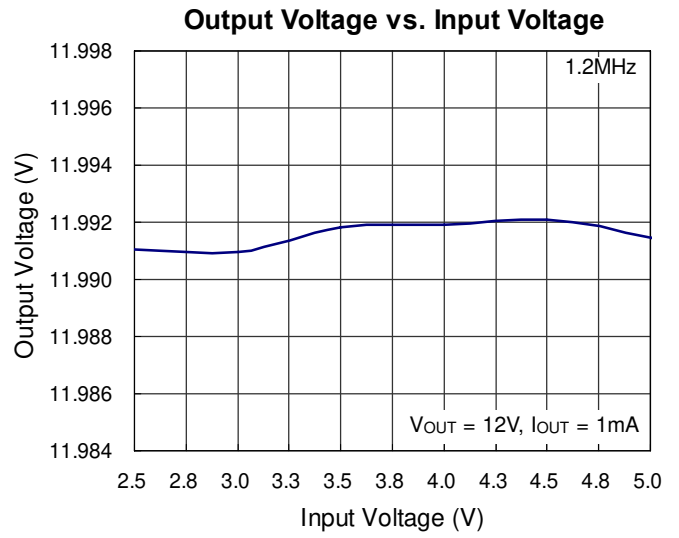
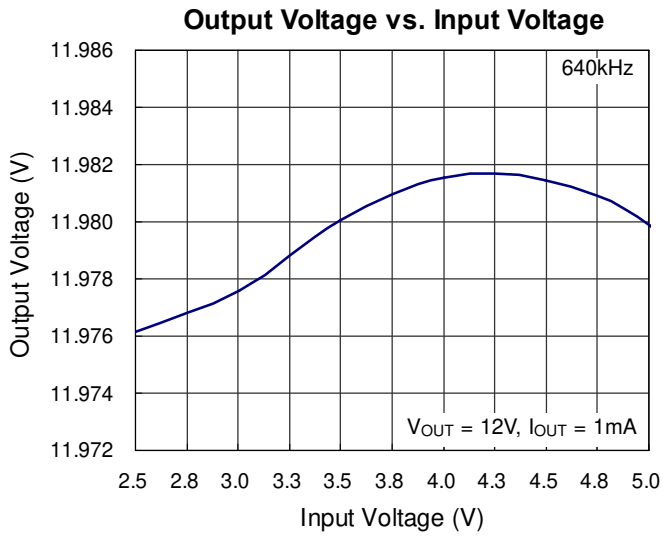

Start Up

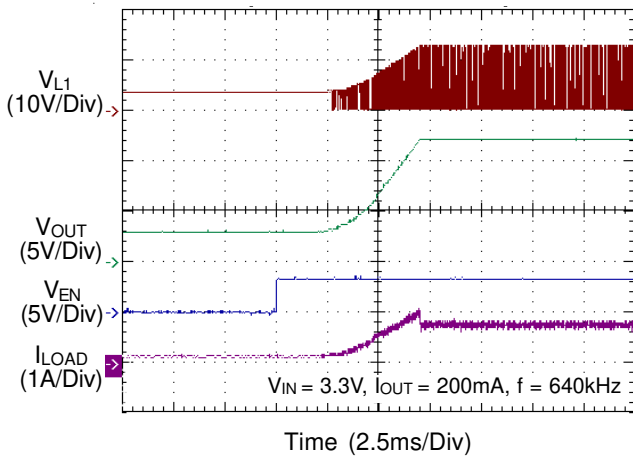

Power Off

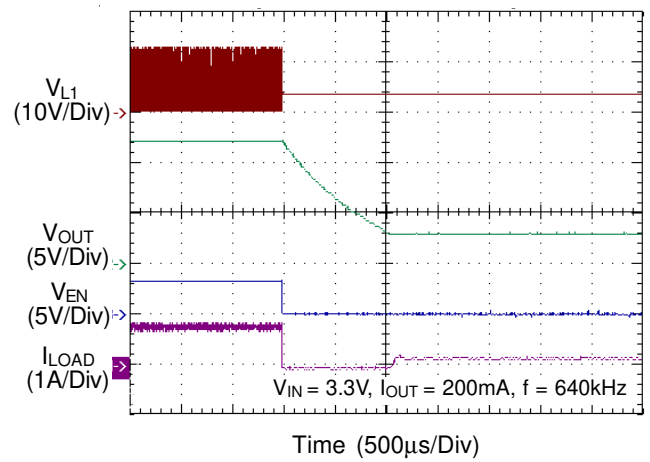

Switching

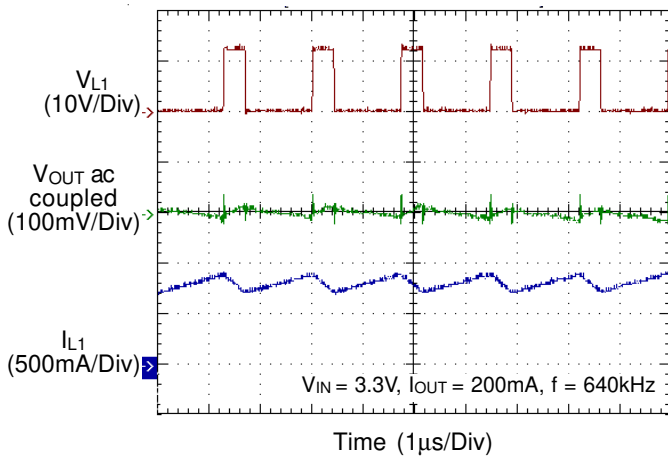

Switching

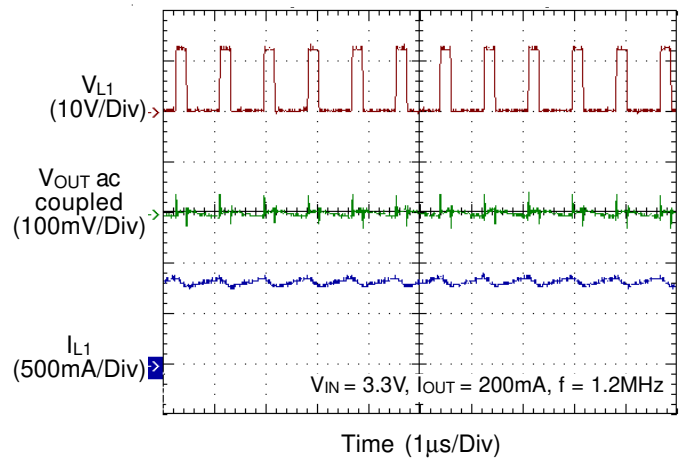

Load Transient Response

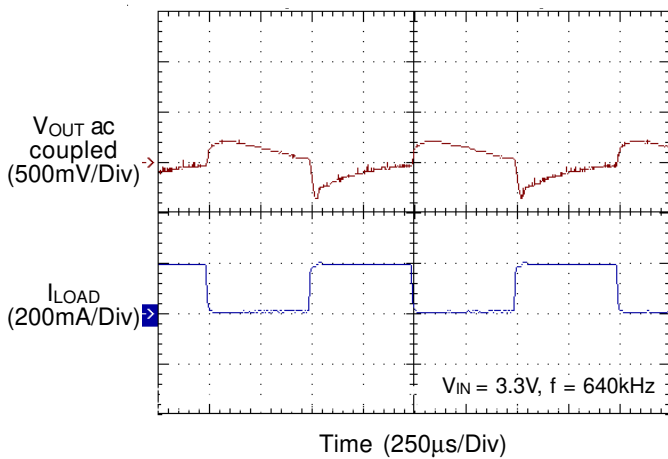

Load Transient Response

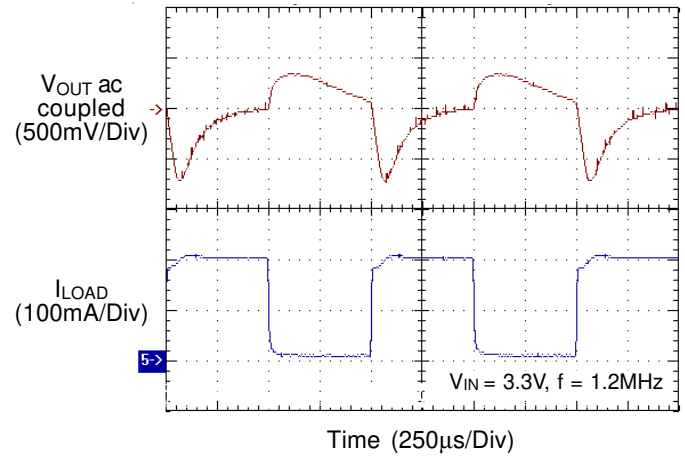

Application Information

The design procedure of Boost converter can start from the maximum input current, which is related about inductor, catch-diode input/output capacitor selections and the maximum power which internal switch can stand. It can be derived from maximum output power, minimum input voltage and the efficiency of Boost converter. Once the maximum input current is calculated, the inductor value can be determined and the other components as well.

Inductor Selection

For a better efficiency in high switching frequency converter, the inductor selection has to use a proper core material such as ferrite core to reduce the core loss and choose low ESR wire to reduce copper loss. The most important point is to prevent the core saturated when handling the maximum peak current. Using a shielded inductor can minimize radiated noise in sensitive applications. The maximum peak inductor current is the maximum input current plus the half of inductor ripple current. The calculated peak current has to be smaller than the current limitation in the electrical characteristics. A typical setting of the inductor ripple current is 20% to 40% of the maximum input current. If the selection is 40%, the maximum peak inductor current is :

$$I_{PEAK} = I_{IN(MAX)} + \frac{1}{2} I_{RIPPLE} = 1.2 \times I_{IN(MAX)}$$

$$= 1.2 \times \left[\frac{I_{OUT(MAX)} \times V_{OUT}}{\eta \times V_{IN(MIN)}} \right]$$

The minimum inductance value is derived from the following equation :

$$L = \frac{\eta \times V_{IN(MIN)}^2 \times [V_{OUT} - V_{IN(MIN)}]}{0.4 \times I_{OUT(MAX)} \times V_{OUT}^2 \times f_{OSC}}$$

Depending on the application, the recommended inductor value is between 2.2μH to 10μH.

Diode Selection

To achieve high efficiency, Schottky diode is good choice for low forward drop voltage and fast switching time. The output diode rating should be able to handle the maximum output voltage, average power dissipation and the pulsating diode peak current.

Input Capacitor Selection

For better input bypassing, low-ESR ceramic capacitors are recommended for performance. A 10μF input capacitor is sufficient for most applications. For a lower output power requirement application, this value can be decreased.

Output Capacitor Selection

For lower output voltage ripple, low-ESR ceramic capacitors are recommended. The tantalum capacitors can be used as well, but the ESR is bigger than ceramic capacitor. The output voltage ripple consists of two components: one is the pulsating output ripple current flows through the ESR, and the other is the capacitive ripple caused by charging and discharging.

$$V_{RIPPLE} = V_{RIPPLE_ESR} + V_{RIPPLE_C}$$

$$\cong I_{PEAK} \times R_{ESR} + \frac{I_{PEAK}}{C_{OUT}} \left(\frac{V_{OUT} - V_{IN}}{V_{OUT} \times f_{OSC}} \right)$$

Output Voltage

The regulated output voltage is calculated by :

$$V_{OUT} = V_{REF} \times \left(1 + \frac{R1}{R2} \right)$$

Where $V_{REF} = 1.24V$ typical.

For most applications, R2 is a suggested a value up to 100kΩ Place the resistor-divider as close to the IC as possible to reduce the noise sensitivity.

Loop Compensation

The RT9277A/B voltage feedback loop can be compensated with an external compensation network consisted of R3, C3 and C4 (As shown in Figure 1). Choose R3 to set the high-frequency integrator gain for fast transient response without over or under compensation. Once R3 is determined, C3 is selected to set the integrator zero to maintain loop stability. The purpose of C4 is to cancel the zero caused by output capacitor and the capacitor ESR. If the ceramic capacitor is selected to be the output capacitor, C4 can be taken off because of the small ESR. C2 is the output capacitor as shown in Figure 1. The following equations give approximate calculations of each component :

$$R3 = \frac{200 \times V_{OUT}^2 \times C2}{L1}$$

$$C3 = \frac{0.4 \times 10^{-3} \times L1}{V_{IN}}$$

$$C4 = \frac{0.005 \times R_{ESR} \times L1}{V_{OUT}^2}$$

The best criterion to optimize the loop compensation is by inspecting the transient response and adjusting the compensation network.

Soft-Start Capacitor

The soft-start function begins from $V_{SS} = 0V$ to $V_{SS} = 1.24V$ with a $4\mu A$ constant current charging to the soft-start capacitor, so the capacitor should be large enough to let the output voltage reach regulation inside the soft-start cycle. Typical value of soft-start capacitor range is from 10nF to 200nF. After the cycle finished, the load can start to draw maximum current as required.

Layout Guideline

For high frequency switching power supplies, the PCB layout is important step in system application design. In order to let IC achieve good regulation, high efficiency and stability, it is strongly recommended the power components should be placed as close as possible. These traces should be wide and short. The feedback pin and the networks of feedback and compensation should keep away from the power loops, and be shielded with a ground trace or plane to prevent noise coupling.

Outline Dimension

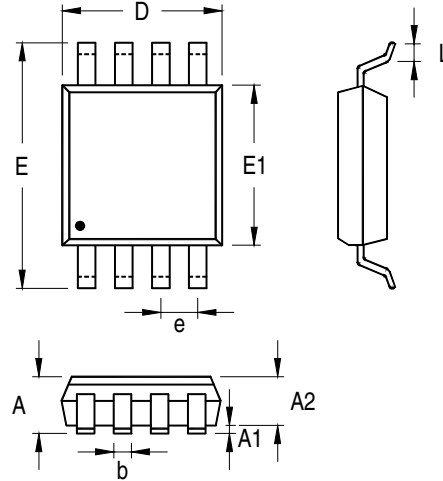

Symbol	Dimensions In Millimeters		Dimensions In Inches	
	Min	Max	Min	Max
A	0.810	1.100	0.032	0.043
A1	0.000	0.150	0.000	0.006
A2	0.750	0.950	0.030	0.037
b	0.220	0.380	0.009	0.015
D	2.900	3.100	0.114	0.122
e	0.650		0.026	
E	4.800	5.000	0.189	0.197
E1	2.900	3.100	0.114	0.122
L	0.400	0.800	0.016	0.031

8-Lead MSOP Plastic Package

Richtek Technology Corporation

Headquarter
 5F, No. 20, Taiyuen Street, Chupei City
 Hsinchu, Taiwan, R.O.C.
 Tel: (8863)5526789 Fax: (8863)5526611

Richtek Technology Corporation

Taipei Office (Marketing)
 5F, No. 95, Minchiuan Road, Hsintien City
 Taipei County, Taiwan, R.O.C.
 Tel: (8862)86672399 Fax: (8862)86672377
 Email: marketing@richtek.com

Information that is provided by Richtek Technology Corporation is believed to be accurate and reliable. Richtek reserves the right to make any change in circuit design, specification or other related things if necessary without notice at any time. No third party intellectual property infringement of the applications should be guaranteed by users when integrating Richtek products into any application. No legal responsibility for any said applications is assumed by Richtek.