

THIS DRAWING IS UNPUBLISHED. RELEASED FOR PUBLICATION
 © COPYRIGHT BY TYCO ELECTRONICS CORPORATION. ALL RIGHTS RESERVED.

LOC		DIST		REVISIONS			
HC	00	P	LTR	DESCRIPTION	DATE	DWN	APVD
		C		REV PER ECO 08-007172	26MAR2008	DW	JL

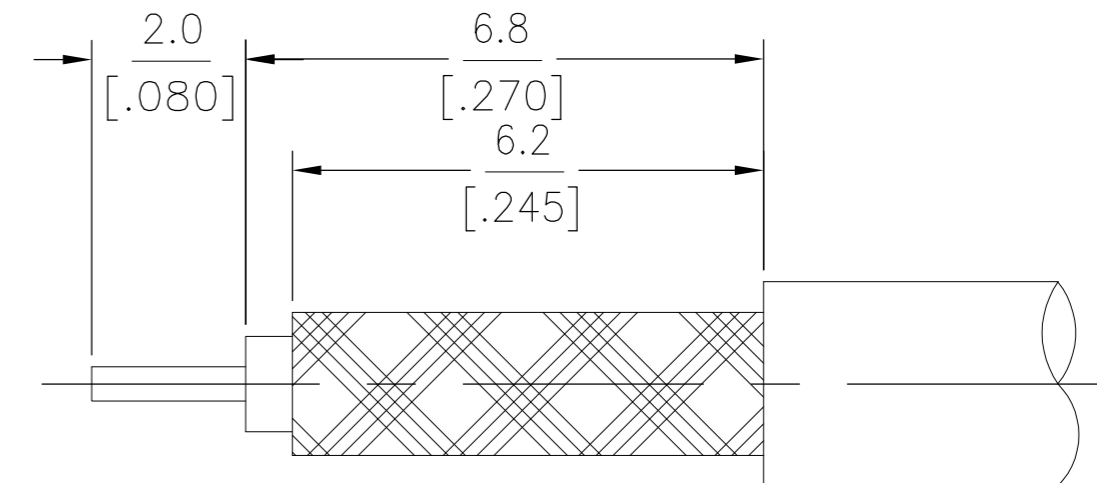

RECOMMENDED STRIP LENGTH

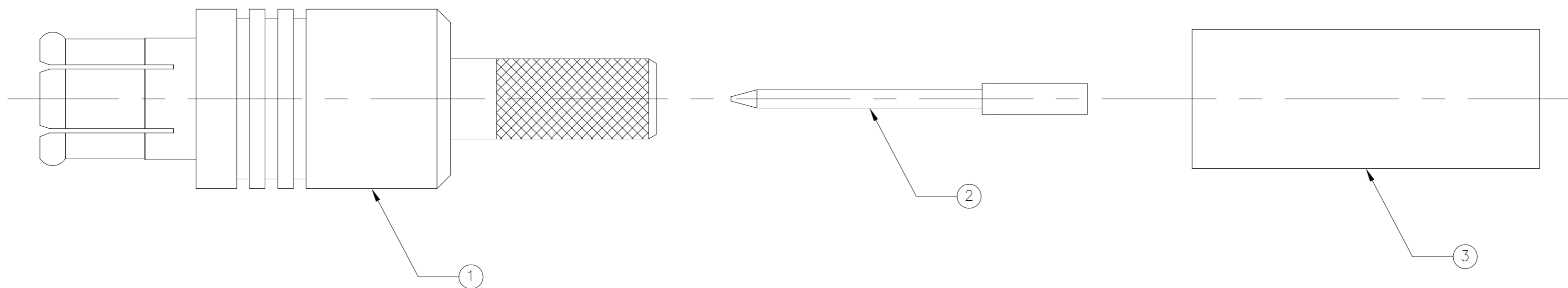

1 BULK PACK IN QTYS OF 100 PIECES EACH:
 100 CONTACTS, 100 FERRULES, 100 PLUG ASSYS

1	OBSOLETE	RD-179	1-413889-4	1408043-2	1408018-1	1362990-3
	OBSOLETE	RD-179	1-413889-4	1408043-2	1408018-1	1362990-2
		RG179/U	1-413889-3	1408043-2	1408018-1	1362990-1
		CABLE SIZE	FERRULE QTY=1 3	CONTACT QTY=1 2	PLUG ASSY. QTY=1 1	PART NUMBER

THIS DRAWING IS A CONTROLLED DOCUMENT.		DWN P.V.C. 07-29-00	Tyco Electronics Corporation Harrisburg, Pa 17105-3608			
DIMENSIONS: mm [INCHES]		CHK -	NAME 75 OHM MCX CABLE PLUG CRIMP ATTACHMENT			
TOLERANCES UNLESS OTHERWISE SPECIFIED:		APVD P.V.C. 08-21-00	SIZE A2 CAGE CODE 00779 DRAWING NO C=1362990 RESTRICTED TO -			
0 PLC ± -		PRODUCT SPEC -	SCALE 10:1 SHEET 1 OF 1 REV C			
1 PLC ± -		APPLICATION SPEC 408-8412	CUSTOMER DRAWING			
2 PLC ± -		WEIGHT -				
3 PLC ± 0.13 [.005]						
4 PLC ± -						
ANGLES ± 1°						
FINISH -						