

Features

- Fast Read Access Time – 90 ns
- Dual Voltage Range Operation
 - Unregulated Battery Power Supply Range, 2.7V to 3.6V
 - or Standard 5V \pm 10% Supply Range
- Compatible with JEDEC Standard AT27C020
- Low-power CMOS Operation
 - 20 μ A max. (Less than 1 μ A Typical) Standby for $V_{CC} = 3.6V$
 - 29 mW max. Active at 5 MHz for $V_{CC} = 3.6V$
- Wide Selection of JEDEC Standard Packages
 - 32-lead PLCC
 - 32-lead TSOP (8 x 20 mm)
 - 32-lead VSOP (8 x 14 mm)
- High Reliability CMOS Technology
 - 2,000V ESD Protection
 - 200 mA Latch-up Immunity
- Rapid™ Programming Algorithm – 100 μ s/Byte (Typical)
- CMOS and TTL Compatible Inputs and Outputs
 - JEDEC Standard for LVTTTL and LVBO
- Integrated Product Identification Code
- Commercial and Industrial Temperature Ranges

Description

The AT27BV020 is a high-performance, low-power, low-voltage, 2,097,152-bit, one-time programmable, read-only memory (OTP EPROM) organized as 256K by 8 bits. It requires only one supply in the range of 2.7 to 3.6V in normal read mode operation, making it ideal for fast, portable systems using either regulated or unregulated battery power. *(continued)*

Pin Configurations

Pin Name	Function
A0 - A17	Addresses
O0 - O7	Outputs
\overline{CE}	Chip Enable
\overline{OE}	Output Enable
\overline{PGM}	Program Strobe
NC	No Connect

PLCC, Top View

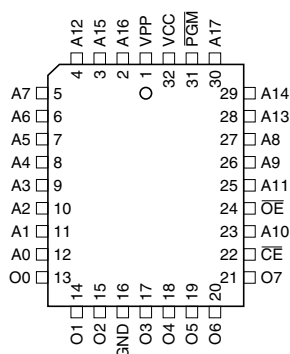

TSOP, VSOP Top View
Type 1

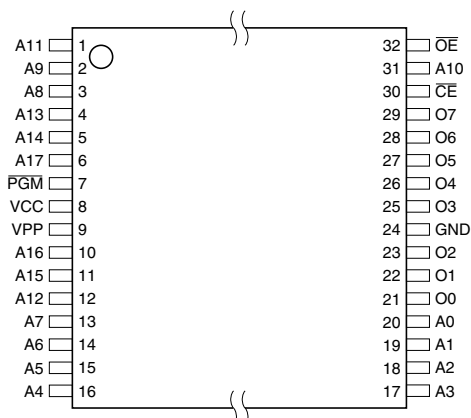

**2-megabit
(256K x 8)
Unregulated
Battery-Voltage™
High-speed
OTP EPROM**

AT27BV020



Atmel's innovative design techniques provide fast speeds that rival 5V parts while keeping the low power consumption of a 3V supply. At $V_{CC} = 2.7V$, any byte can be accessed in less than 90 ns. With a typical power dissipation of only 18 mW at 5 MHz and $V_{CC} = 3V$, the AT27BV020 consumes less than one fifth the power of a standard 5V EPROM. Standby mode supply current is typically less than 1 μA at 3V. The AT27BV020 simplifies system design and stretches battery lifetime even further by eliminating the need for power supply regulation

The AT27BV020 is available in industry standard JEDEC approved one-time programmable (OTP) plastic PLCC, TSOP and VSOP packages, as well as a 42-ball, 1 mm pitch. All devices feature two-line control (\overline{CE} , \overline{OE}) to give designers the flexibility to prevent bus contention.

The AT27BV020 operating with V_{CC} at 3.0V produces TTL level outputs that are compatible with standard TTL logic devices operating at $V_{CC} = 5.0V$. At $V_{CC} = 2.7V$, the part is compatible with JEDEC approved low voltage battery operation (LVBO) interface specifications. The device is also capable of standard 5-volt operation making it ideally suited for dual supply range systems or card products that are pluggable in both 3-volt and 5-volt hosts.

Atmel's AT27BV020 has additional features to ensure high quality and efficient production use. The Rapid™ Programming Algorithm reduces the time required to program the

part and guarantees reliable programming. Programming time is typically only 100 μs /byte. The Integrated Product Identification Code electronically identifies the device and manufacturer. This feature is used by industry standard programming equipment to select the proper programming algorithms and voltages. The AT27BV020 programs exactly the same way as a standard 5V AT27C020 and uses the same programming equipment.

System Considerations

Switching between active and standby conditions via the Chip Enable pin may produce transient voltage excursions. Unless accommodated by the system design, these transients may exceed data sheet limits, resulting in device nonconformance. At a minimum, a 0.1 μF high frequency, low inherent inductance, ceramic capacitor should be utilized for each device. This capacitor should be connected between the V_{CC} and Ground terminals of the device, as close to the device as possible. Additionally, to stabilize the supply voltage level on printed circuit boards with large EPROM arrays, a 4.7 μF bulk electrolytic capacitor should be utilized, again connected between the V_{CC} and Ground terminals. This capacitor should be positioned as close as possible to the point where the power supply is connected to the array.

Block Diagram

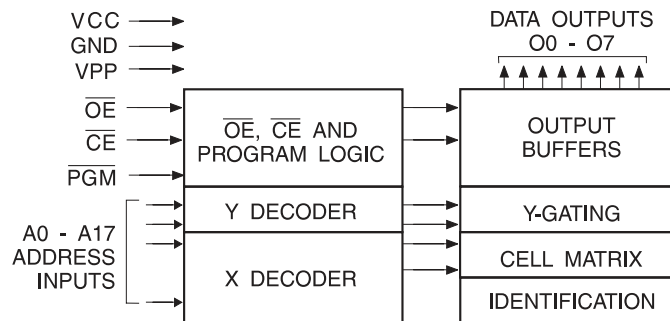

Absolute Maximum Ratings*

Temperature under Bias	-40°C to +85°C
Storage Temperature	-65°C to +125°C
Voltage on Any Pin with Respect to Ground	-2.0V to +7.0V ⁽¹⁾
Voltage on A9 with Respect to Ground	-2.0V to +14.0V ⁽¹⁾
V _{PP} Supply Voltage with Respect to Ground	-2.0V to +14.0V ⁽¹⁾

*NOTICE: Stresses beyond those listed under “Absolute Maximum Ratings” may cause permanent damage to the device. This is a stress rating only and functional operation of the device at these or any other conditions beyond those indicated in the operational sections of this specification is not implied. Exposure to absolute maximum rating conditions for extended periods may affect device reliability.

Note: 1. Minimum voltage is -0.6V DC which may undershoot to -2.0V for pulses of less than 20 ns. Maximum output pin voltage is V_{CC} + 0.75V DC which may be exceeded if certain precautions are observed (consult application notes) and which may overshoot to +7.0V for pulses of less than 20 ns.

Operating Modes

Mode / Pin	\overline{CE}	\overline{OE}	\overline{PGM}	Ai	V _{PP}	V _{CC}	Outputs
Read ⁽²⁾	V _{IL}	V _{IL}	X ⁽¹⁾	Ai	X	V _{CC} ⁽²⁾	D _{OUT}
Output Disable ⁽²⁾	X	V _{IH}	X	X	X	V _{CC} ⁽²⁾	High-Z
Standby ⁽²⁾	V _{IH}	X	X	X	X	V _{CC} ⁽²⁾	High-Z
Rapid Program ⁽³⁾	V _{IL}	V _{IH}	V _{IL}	Ai	V _{PP}	V _{CC} ⁽³⁾	D _{IN}
PGM Verify ⁽³⁾	V _{IL}	V _{IL}	V _{IH}	Ai	V _{PP}	V _{CC} ⁽³⁾	D _{OUT}
PGM Inhibit ⁽³⁾	V _{IH}	X	X	X	V _{PP}	V _{CC} ⁽³⁾	High-Z
Product Identification ⁽³⁾⁽⁵⁾	V _{IL}	V _{IL}	X	A9 = V _H ⁽⁴⁾ A0 = V _{IH} or V _{IL} A1 - A17 = V _{IL}	X	V _{CC} ⁽³⁾	Identification Code

- Notes:
1. X Can be V_{IL} or V_{IH}.
 2. Read, output disable, and standby modes require, 2.7V ≤ V_{CC} ≤ 3.6V, or 4.5V ≤ V_{CC} ≤ 5.5V.
 3. Refer to Programming Characteristics. Programming modes requires V_{CC} = 6.5V.
 4. V_H = 12.0 ± 0.5V.
 5. Two identifier bytes may be selected. All Ai inputs are held low (V_{IL}), except A9 which is set to V_H and A0 which is toggled low (V_{IL}) to select the Manufacturer's Identification byte and high (V_{IH}) to select the Device Code byte.



DC and AC Operating Conditions for Read Operation

		AT27BV020-90	AT27BV020-12	AT27BV020-15
Operating Temperature (Case)	Com.	0°C - 70°C	0°C - 70°C	0°C - 70°C
	Ind.	-40°C - 85°C	-40°C - 85°C	-40°C - 85°C
V _{CC} Power Supply		2.7V to 3.6V	2.7V to 3.6V	2.7V to 3.6V
		5V ± 10%	5V ± 10%	5V ± 10%

DC and Operating Characteristics for Read Operation

Symbol	Parameter	Condition	Min	Max	Units
V_{CC} = 2.7V to 3.6V					
I _{LI}	Input Load Current	V _{IN} = 0V to V _{CC}		±1	μA
I _{LO}	Output Leakage Current	V _{OUT} = 0V to V _{CC}		±5	μA
I _{PP1} ⁽²⁾	V _{PP} ⁽¹⁾ Read/Standby Current	V _{PP} = V _{CC}		10	μA
I _{SB}	V _{CC} ⁽¹⁾ Standby Current	I _{SB1} (CMOS), $\overline{CE} = V_{CC} \pm 0.3V$		20	μA
		I _{SB2} (TTL), $\overline{CE} = 2.0$ to V _{CC} + 0.5V		100	μA
I _{CC}	V _{CC} Active Current	f = 5 MHz, I _{OUT} = 0 mA, $\overline{CE} = V_{IL}$, V _{CC} = 3.6V		8	mA
V _{IL}	Input Low Voltage	V _{CC} = 3.0 to 3.6V	-0.6	0.8	V
		V _{CC} = 2.7 to 3.6V	-0.6	0.2 x V _{CC}	V
V _{IH}	Input High Voltage	V _{CC} = 3.0 to 3.6V	2.0	V _{CC} + 0.5	V
		V _{CC} = 2.7 to 3.6V	0.7 x V _{CC}	V _{CC} + 0.5	V
V _{OL}	Output Low Voltage	I _{OL} = 2.0 mA		0.4	V
		I _{OL} = 100 μA		0.2	V
		I _{OL} = 20 μA		0.1	V
V _{OH}	Output High Voltage	I _{OH} = -2.0 mA	2.4		V
		I _{OH} = -100 μA	V _{CC} - 0.2		V
		I _{OH} = -20 μA	V _{CC} - 0.1		V
V_{CC} = 4.5V to 5.5V					
I _{LI}	Input Load Current	V _{IN} = 0V to V _{CC}		±1	μA
I _{LO}	Output Leakage Current	V _{OUT} = 0V to V _{CC}		±5	μA
I _{PP1} ⁽²⁾	V _{PP} ⁽¹⁾ Read/Standby Current	V _{PP} = V _{CC}		10	μA
I _{SB}	V _{CC} ⁽¹⁾ Standby Current	I _{SB1} (CMOS), $\overline{CE} = V_{CC} \pm 0.3V$		100	μA
		I _{SB2} (TTL), $\overline{CE} = 2.0$ to V _{CC} + 0.5V		1	mA
I _{CC}	V _{CC} Active Current	f = 5 MHz, I _{OUT} = 0 mA, $\overline{CE} = V_{IL}$		25	mA
V _{IL}	Input Low Voltage		-0.6	0.8	V
V _{IH}	Input High Voltage		2.0	V _{CC} + 0.5	V
V _{OL}	Output Low Voltage	I _{OL} = 2.1 mA		0.4	V
V _{OH}	Output High Voltage	I _{OH} = -400 μA	2.4		V

- Notes: 1. V_{CC} must be applied simultaneously with or before V_{PP} and removed simultaneously with or after V_{PP}
 2. V_{PP} may be connected directly to V_{CC}, except during programming. The supply current would then be the sum of I_{CC} and I_{PP}

AC Characteristics for Read Operation

$V_{CC} = 2.7V$ to $3.6V$ and $4.5V$ to $5.5V$

Symbol	Parameter	Condition	AT27BV020						Units
			-90		-12		-15		
			Min	Max	Min	Max	Min	Max	
$t_{ACC}^{(3)}$	Address to Output Delay	$\overline{CE} = \overline{OE} = V_{IL}$		90		120		150	ns
$t_{CE}^{(2)}$	\overline{CE} to Output Delay	$\overline{OE} = V_{IL}$		90		120		150	ns
$t_{OE}^{(2)(3)}$	\overline{OE} to Output Delay	$\overline{CE} = V_{IL}$		50		50		60	ns
$t_{DF}^{(4)(5)}$	\overline{OE} or \overline{CE} High to Output Float, whichever occurred first			40		40		50	ns
t_{OH}	Output Hold from Address, \overline{CE} or \overline{OE} , whichever occurred first		0		0		0		ns

Note: 2,3,4,5. – See “AC Waveforms for Read Operation”.

AC Waveforms for Read Operation⁽¹⁾

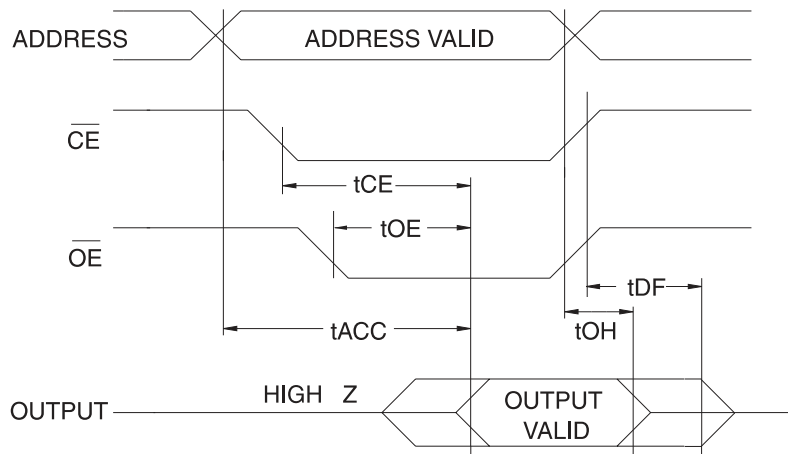

- Notes:
1. Timing measurement references are 0.8V and 2.0V. Input AC drive levels are 0.45V and 2.4V, unless otherwise specified.
 2. \overline{OE} may be delayed up to $t_{CE} - t_{OE}$ after the falling edge of \overline{CE} without impact on t_{CE} .
 3. \overline{OE} may be delayed up to $t_{ACC} - t_{OE}$ after the address is valid without impact on t_{ACC} .
 4. This parameter is only sampled and is not 100% tested.
 5. Output float is defined as the point when data is no longer driven.

Input Test Waveform and Measurement Level

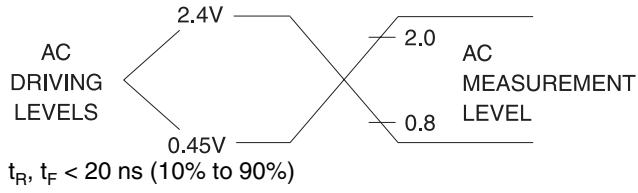

Output Test Load

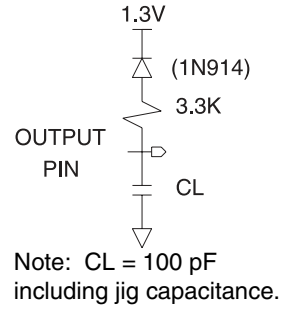

Pin Capacitance

$f = 1 \text{ MHz}, T = 25^\circ\text{C}^{(1)}$

Symbol	Typ	Max	Units	Conditions
C_{IN}	4	8	pF	$V_{IN} = 0V$
C_{OUT}	8	12	pF	$V_{OUT} = 0V$

Note: 1. Typical values for nominal supply voltage. This parameter is only sampled and is not 100% tested.

Programming Waveforms⁽¹⁾

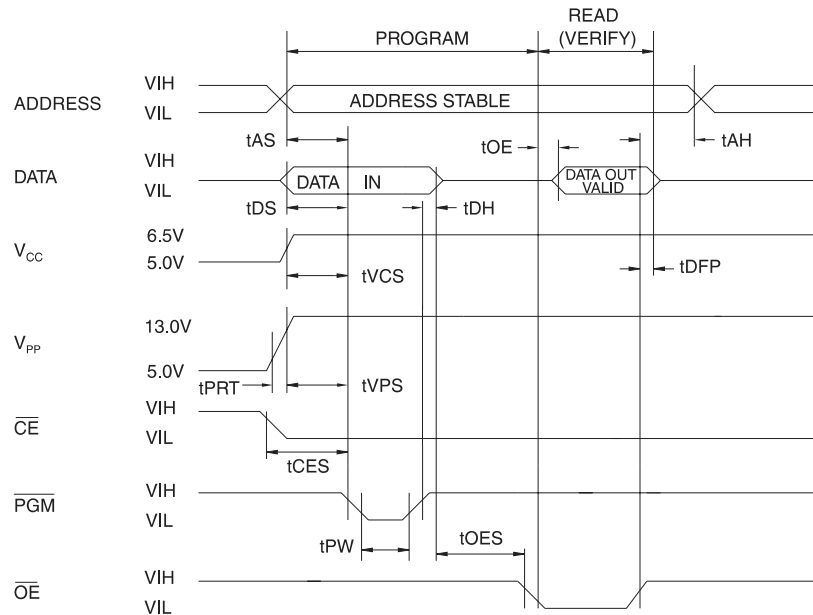

- Notes:
1. The Input Timing Reference is 0.8V for V_{IL} and 2.0V for V_{IH} .
 2. t_{OE} and t_{DFP} are characteristics of the device but must be accommodated by the programmer.
 3. When programming the AT27BV020 a 0.1 μ F capacitor is required across V_{PP} and ground to suppress spurious voltage transients.

DC Programming Characteristics

$T_A = 25 \pm 5^\circ\text{C}$, $V_{CC} = 6.5 \pm 0.25\text{V}$, $V_{PP} = 13.0 \pm 0.25\text{V}$

Symbol	Parameter	Test Conditions	Limits		Units
			Min	Max	
I_{LI}	Input Load Current	$V_{IN} = V_{IL}, V_{IH}$		± 10	μA
V_{IL}	Input Low Level		-0.6	0.8	V
V_{IH}	Input High Level		2.0	$V_{CC} + 0.5$	V
V_{OL}	Output Low Voltage	$I_{OL} = 2.1 \text{ mA}$		0.4	V
V_{OH}	Output High Voltage	$I_{OH} = -400 \mu\text{A}$	2.4		V
I_{CC2}	V_{CC} Supply Current (Program and Verify)			40	mA
I_{PP2}	V_{PP} Supply Current	$\overline{CE} = \overline{PGM} = V_{IL}$		20	mA
V_{ID}	A9 Product Identification Voltage		11.5	12.5	V



AC Programming Characteristics

$T_A = 25 \pm 5^\circ\text{C}$, $V_{CC} = 6.5 \pm 0.25\text{V}$, $V_{PP} = 13.0 \pm 0.25\text{V}$

Symbol	Parameter	Test Conditions ⁽¹⁾	Limits		Units
			Min	Max	
t_{AS}	Address Setup Time	Input Rise and Fall Times: (10% to 90%) 20ns Input Pulse Levels: 0.45V to 2.4V Input Timing Reference Level: 0.8V to 2.0V Output Timing Reference Level: 0.8V to 2.0V	2		μs
t_{CES}	\overline{CE} Setup Time		2		μs
t_{OES}	\overline{OE} Setup Time		2		μs
t_{DS}	Data Setup Time		2		μs
t_{AH}	Address Hold Time		0		μs
t_{DH}	Data Hold Time		2		μs
t_{DFP}	\overline{OE} High to Output Float Delay ⁽³⁾		0	130	ns
t_{VPS}	V_{PP} Setup Time		2		μs
t_{VCS}	V_{CC} Setup Time		2		μs
t_{PW}	\overline{PGM} Program Pulse Width ⁽²⁾		95	105	μs
t_{OE}	Data Valid from \overline{OE}		150	ns	
t_{PRT}	V_{PP} Pulse Rise Time During Programming	50		ns	

- Notes:
- V_{CC} must be applied simultaneously or before V_{PP} and removed simultaneously or after V_{PP}
 - This parameter is only sampled and is not 100% tested. Output Float is defined as the point where data is no longer driven —see timing diagram.
 - Program Pulse width tolerance is $100 \mu\text{sec} \pm 5\%$.

Atmel's 27BV020 Integrated Product Identification Code⁽¹⁾

Codes	Pins									Hex Data
	A0	O7	O6	O5	O4	O3	O2	O1	O0	
Manufacturer	0	0	0	0	1	1	1	1	0	1E
Device Type	1	1	0	0	0	0	1	1	0	86

- Note:
- The AT27BV020 has the same Product Identification Code as the AT27C020. Both are programming compatible.

Rapid Programming Algorithm

A 100 μs $\overline{\text{PGM}}$ pulse width is used to program. The address is set to the first location. V_{CC} is raised to 6.5V and V_{PP} is raised to 13.0V. Each address is first programmed with one 100 μs $\overline{\text{PGM}}$ pulse without verification. Then a verification/reprogramming loop is executed for each address. In the event a byte fails to pass verification, up to 10 successive 100 μs pulses are applied with a verification

after each pulse. If the byte fails to verify after 10 pulses have been applied, the part is considered failed. After the byte verifies properly, the next address is selected until all have been checked. V_{PP} is then lowered to 5.0V and V_{CC} to 5.0V. All bytes are read again and compared with the original data to determine if the device passes or fails.

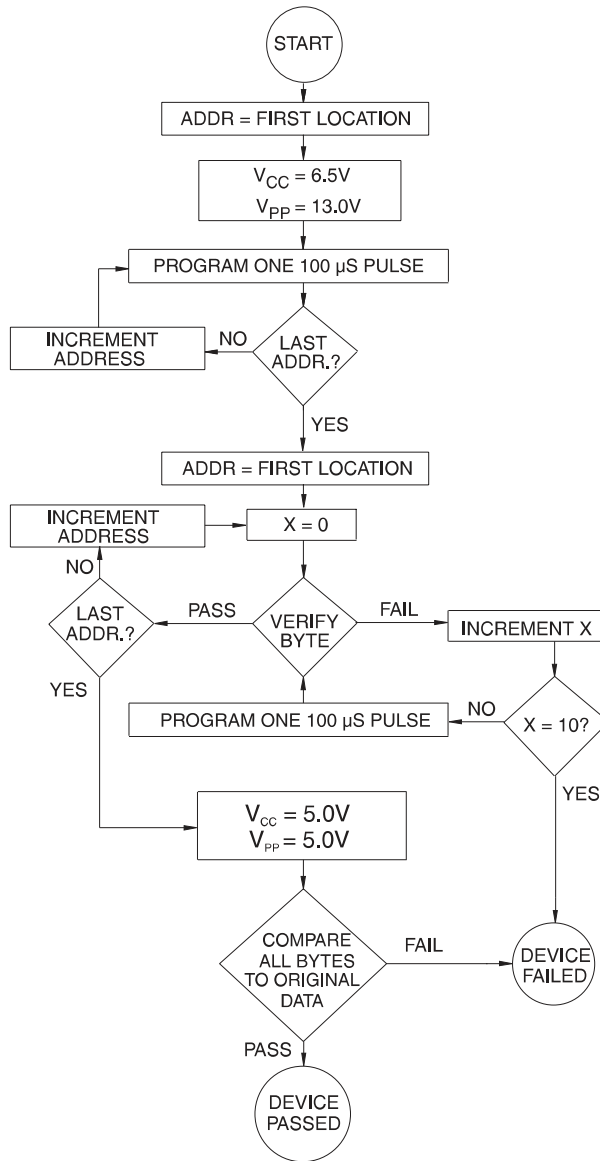



Ordering Information

t_{ACC} (ns)	I_{CC} (mA) $V_{CC} = 3.6V$		Ordering Code	Package	Operation Range
	Active	Standby			
90	8	0.02	AT27BV020-90JC AT27BV020-90TC AT27BV020-90VC	32J 32T 32V	Commercial (0°C to 70°C)
	8	0.02	AT27BV020-90JI AT27BV020-90TI AT27BV020-90VI	32J 32T 32V	Industrial (-40°C to 85°C)
120	8	0.02	AT27BV020-12JC AT27BV020-12TC AT27BV020-12VC	32J 32T 32V	Commercial (0°C to 70°C)
	8	0.02	AT27BV020-12JI AT27BV020-12TI AT27BV020-12VI	32J 32T 32V	Industrial (-40°C to 85°C)
150	8	0.02	AT27BV020-15JC AT27BV020-15TC AT27BV020-15VC	32J 32T 32V	Commercial (0°C to 70°C)
	8	0.02	AT27BV020-15JI AT27BV020-15TI AT27BV020-15VI	32J 32T 32V	Industrial (-40°C to 85°C)

Package Type	
32J	32-lead, Plastic J-leaded Chip Carrier (PLCC)
32T	32-lead, Plastic Thin Small Outline Package (TSOP) (8 x 20 mm)
32V	32-lead, Plastic Thin Small Outline Package (VSOP) (8 x 14 mm)

Packaging Information

32J, 32-lead, Plastic J-leaded Chip Carrier (PLCC)
 Dimensions in Inches and (Millimeters)
 JEDEC STANDARD MS-016 AE

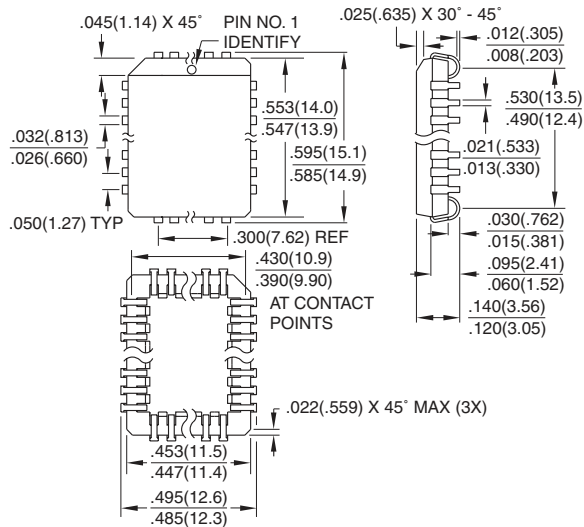

32T, 32-lead, Plastic Thin Small Outline Package (TSOP)
 Dimensions in Millimeters and (Inches)*
 JEDEC OUTLINE MO-142 BD
 *

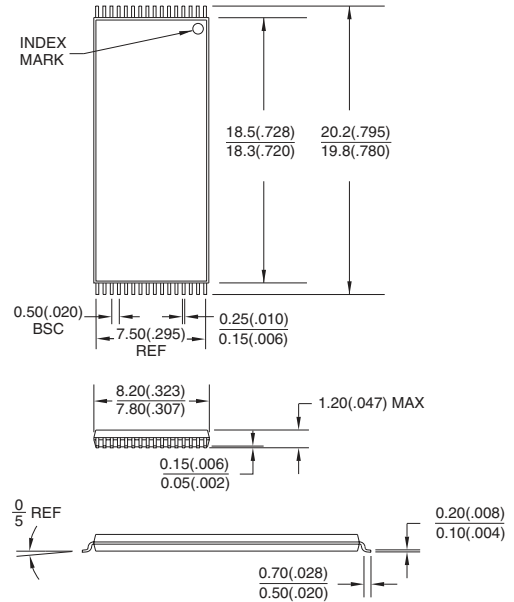

*Controlling dimension: millimeters

32V, 32-lead, Plastic Thin Small Outline Package (TSOP)
 Dimensions in Millimeters and (Inches)

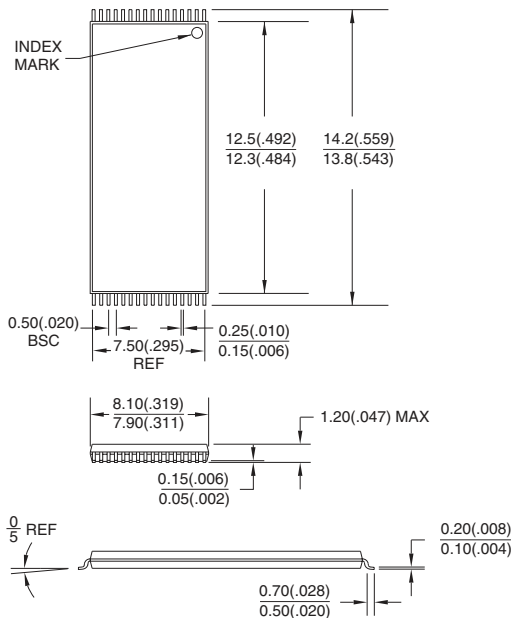



Atmel Headquarters

Corporate Headquarters
2325 Orchard Parkway
San Jose, CA 95131
TEL (408) 441-0311
FAX (408) 487-2600

Europe

Atmel SarL
Route des Arsenaux 41
Casa Postale 80
CH-1705 Fribourg
Switzerland
TEL (41) 26-426-5555
FAX (41) 26-426-5500

Asia

Atmel Asia, Ltd.
Room 1219
Chinachem Golden Plaza
77 Mody Road Tsimhatsui
East Kowloon
Hong Kong
TEL (852) 2721-9778
FAX (852) 2722-1369

Japan

Atmel Japan K.K.
9F, Tonetsu Shinkawa Bldg.
1-24-8 Shinkawa
Chuo-ku, Tokyo 104-0033
Japan
TEL (81) 3-3523-3551
FAX (81) 3-3523-7581

Atmel Operations

Atmel Colorado Springs
1150 E. Cheyenne Mtn. Blvd.
Colorado Springs, CO 80906
TEL (719) 576-3300
FAX (719) 540-1759

Atmel Rousset
Zone Industrielle
13106 Rousset Cedex
France
TEL (33) 4-4253-6000
FAX (33) 4-4253-6001

Atmel Smart Card ICs
Scottish Enterprise Technology Park
East Kilbride, Scotland G75 0QR
TEL (44) 1355-357-000
FAX (44) 1355-242-743

Atmel Grenoble
Avenue de Rochepleine
BP 123
38521 Saint-Egreve Cedex
France
TEL (33) 4-7658-3000
FAX (33) 4-7658-3480

Fax-on-Demand

North America:
1-(800) 292-8635
International:
1-(408) 441-0732

e-mail

literature@atmel.com

Web Site

<http://www.atmel.com>

BBS

1-(408) 436-4309

© Atmel Corporation 2001.

Atmel Corporation makes no warranty for the use of its products, other than those expressly contained in the Company's standard warranty which is detailed in Atmel's Terms and Conditions located on the Company's web site. The Company assumes no responsibility for any errors which may appear in this document, reserves the right to change devices or specifications detailed herein at any time without notice, and does not make any commitment to update the information contained herein. No licenses to patents or other intellectual property of Atmel are granted by the Company in connection with the sale of Atmel products, expressly or by implication. Atmel's products are not authorized for use as critical components in life support devices or systems.

Marks bearing ® and/or ™ are registered trademarks and trademarks of Atmel Corporation.

Terms and product names in this document may be trademarks of others.



Printed on recycled paper.

0902D-04/01/xM