

### Precautions

#### ■Precautions for Safe Use

Use the Switch within the rated voltage and current ranges, otherwise the Switch may have a shortened life expectancy, radiate heat, or burn out. This particularly applies to the instantaneous voltages and currents when switching.

#### ■Precautions for Correct Use

##### ● Storage

##### Storage Environment

To prevent degradation, such as discoloration, in the terminals during storage, do not store the Switch in locations that are subject to the following conditions.

1. High temperature or humidity
2. Corrosive gases
3. Direct sunlight

##### Storage condition

Store the Switches in the packaging box.

After the packaging box is opened, use the contents as quickly as possible. When storing leftover parts, make sure that appropriate measures are taken against humidity and corrosive gases.

##### ● Handling

##### 1. Operation

Do not repeatedly operate the Switch with excessive force. Applying excessive pressure or applying additional force after the plunger has stopped may deform the contact dome of the Switch, resulting in malfunction. In particular, applying excessive force to Side-operated Switches may damage the caulking, which in turn may damage the Switch. Do not apply force exceeding the maximum (29.4 N {300 gf} for 1 minute, one time) when installing or operating Side-operated Switches.

Be sure to set up the Switch so that the plunger will operate in a straight vertical line. A decrease in the life of the Switch may result if the plunger is pressed off-center or from an angle.

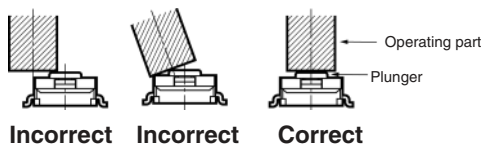

Tactile Switch is not recommended to use for detection purpose due to the sort of Manual Switch. Omron's Detection Switch is recommended for this purpose.

##### 2. Dust Protection

Do not use Switches that are not sealed in dust-prone environments. Doing so may cause dust to penetrate inside the Switch and cause contact failure. If a Switch that is not sealed must be used in this kind of environment, use a sheet or other measure to protect it against dust.

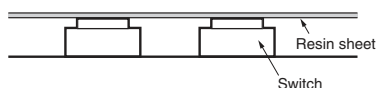

#### 3. Usage Environment

Before installing the Switch, make sure that the area of installation is not subject to corrosive gases emitted from surrounding parts.

Do not use in areas subject to high temperatures, high humidity, or toxic gases such as sulfuric gas (H<sub>2</sub>S, SO<sub>2</sub>), ammonia gas (NH<sub>3</sub>), nitric gas (HNO<sub>3</sub>), or chlorine gas (Cl<sub>2</sub>). It can cause corrosive damage to the contacts and result in malfunction. If there is silicon in the atmosphere, it may stop the contacts from functioning properly.

If silicon products, such as silicon oil, silicon filler, or silicon wires, are used in the surrounding area, install a contact protection circuit to prevent arcing or remove the silicon source.

The following situations may cause water to enter inside the Switch, resulting in a malfunction due to contact failure or corrosion.

- Using the Switch in an outdoor environment where it is exposed to water drops for an extended period of time.
- Using the Switch in an underwater setting where it is subject to strong water pressure.

Do not use Switches that have been dropped. The mating section or other internal parts may be damaged, resulting in malfunction.

##### ● PCBs

The Switch is designed for a 1.6-mm thick, single-side PCB. Using PCBs with a different thickness or using double-sided, through-hole PCBs may result in loose mounting, improper insertion, or poor heat resistance in soldering. These effects will occur, depending on the type of holes and patterns of the PCB. Therefore, it is recommended that a verification test is conducted before use.

If the PCBs are separated after mounting the Switch, particles from the PCBs may enter the Switch. If PCB particles or foreign particles from the surrounding environment, workbench, containers, or stacked PCBs become attached to the Switch, contact failure may result.

##### ● Soldering

##### 1. General Precautions

Before soldering the Switch on a multilayer PCB, test to confirm that soldering can be performed properly. Otherwise the Switch may be deformed by the soldering heat on the pattern or lands of the multilayer PCB.

Do not solder the Switch more than twice, including rectification soldering. An interval of five minutes is required between the first and the second soldering.

##### 2. Automatic Soldering Baths (B3F, B3W, B3WN, B3M, B3J)

Soldering temperature: 260°C max.

Soldering time: 5 s max. for a 1.6-mm thick single-side PCB

Preheating temperature: 100°C max. (ambient temperature)

Preheating time: Within 60 s

Make sure that no flux will rise above the level of the PCB. If flux overflows onto the mounting surface of the PCB, it may enter the Switch and cause a malfunction.

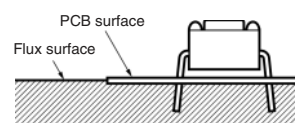

**3. Reflow Soldering (Surface Mounting)**

Solder the terminals within the heating curve shown in the following diagram.

**B3S, B3SN, B3FS**

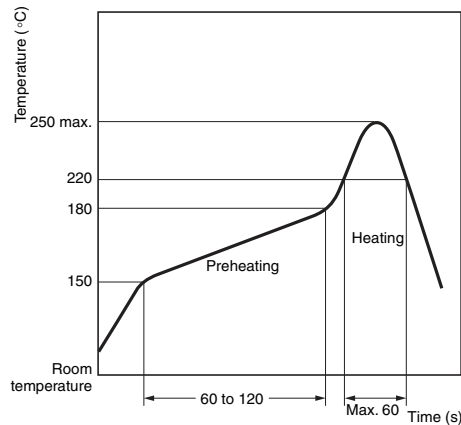

**B3SL, B3U, B3AL, B3SE**

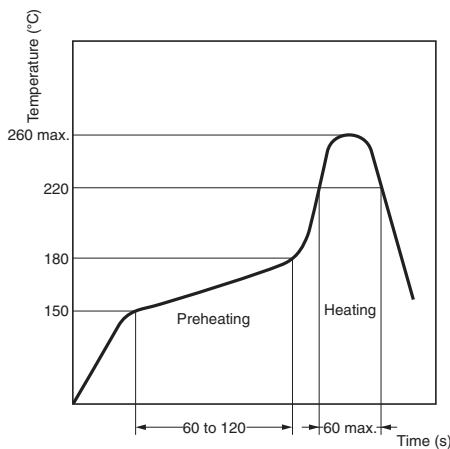

**Note:** The above heating curve applies if the PCB thickness is 1.6 mm.

The peak temperature may vary depending on the reflow bath used. Confirm the conditions beforehand.

Do not use an automatic soldering bath for surface-mounted Switches. The soldering gas or flux may enter the Switch and damage the Switch's plunger operation.

**4. Manual Soldering (All Models)**

Soldering temperature: 350°C max. at the tip of the soldering iron  
 Soldering time: 3 s max. for a 1.6-mm thick, single-side PCB  
 Before soldering the Switch on a PCB, make sure that there is no unnecessary space between the Switch and the PCB.

● **Washing**

**1. Washable and Non-washable Models**

<b>Washable (sealed types)</b>	B3W, B3WN, B3S, B3SN
<b>Non-washable (standard types)</b>	B3F, B3FS, B3SL, B3W-9, B3J, B3M, B3U, B3AL, B3SE

Standard Switches are not sealed, and cannot be washed. Doing so will cause the washing agent, together with flux or dust particles on the PCB, to enter the Switch, resulting in malfunction.

**2. Washing Methods**

Washing equipment incorporating more than one washing bath can be used to clean washable models, provided that the washable models are cleaned for one minute maximum per bath and the total cleaning time does not exceed three minutes.

**3. Washing Agents**

Apply alcohol-based solvents to clean washable models. Do not apply any other agents or water to clean any washable model, as such agents may degrade the materials or performance of the Switch.

**4. Washing Precautions**

Do not impose any external force on washable models while washing.

Do not clean washable models immediately after soldering. The cleaning agent may be absorbed into the Switch through respiration as the Switch cools. Wait for at least three minutes after soldering before cleaning washable models.

Do not use Sealed Switches while submersed in water or in locations exposed to water.

● **Switch Packaging (Taping Specification Models)**

**1. Radial Types**

The tape is packaged by fan-folding into the box, as shown in the following diagram.

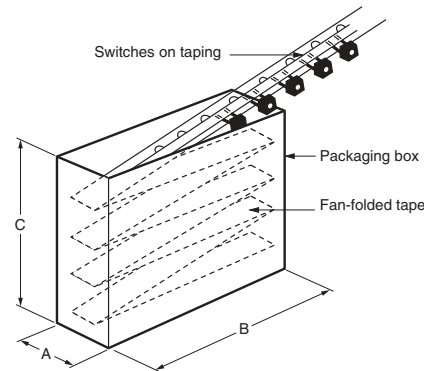

Model	A	B	C
<b>B3F</b>	50 mm	325 mm	275 mm
<b>B3WN</b>	53 mm	326 mm	350 mm

Do not apply any external force to the packaging box, or subject it to vibration. Doing so may deform the Switch terminals.

Remove the tape slowly, making sure that the Switches are not entangled or caught. Otherwise the terminals may be deformed. Do not store the packaged Switches in locations subject to high temperatures or high humidity. The packaging boxes are sealed with paper tape and are not airtight. Storing the packaged Switches in locations with high temperature or high humidity may result in deterioration of the tape and Switches, and long-term storage under such conditions may cause discoloration of the Switch terminals.

2. Packaging Specifications for Embossed Taping

<B3FS-1000P, B3SN>

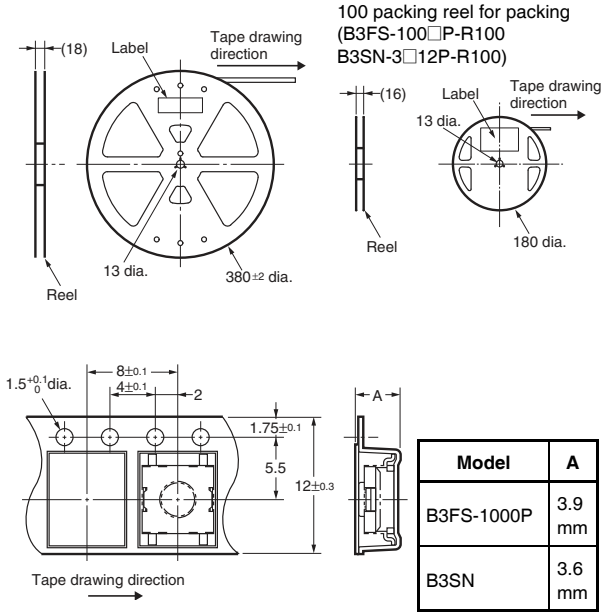

<b>Standards</b>	Conforms to JIS.
<b>Package</b>	3,000 Switches (B3FS-100□P) 3,000 Switches (B3SN-3□12P) 100 Switches (B3FS-100□P-R100) 100 Switches (B3SN-3□12P-R100)

**Note:** Switches with ground terminals are packaged with the ground terminal on the side of the guide hole.

<B3FS-1050P>

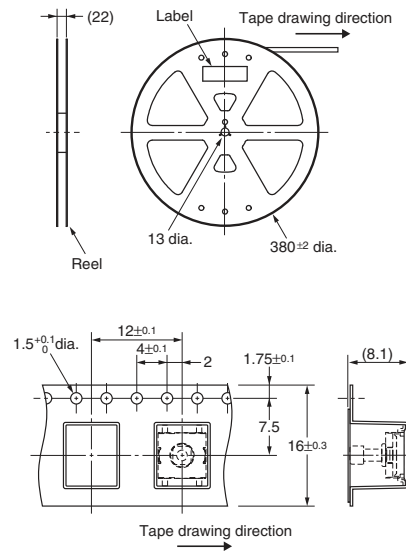

<b>Standards</b>	Conforms to JIS.
<b>Package</b>	1,000 Switches

<B3FS-1010P>

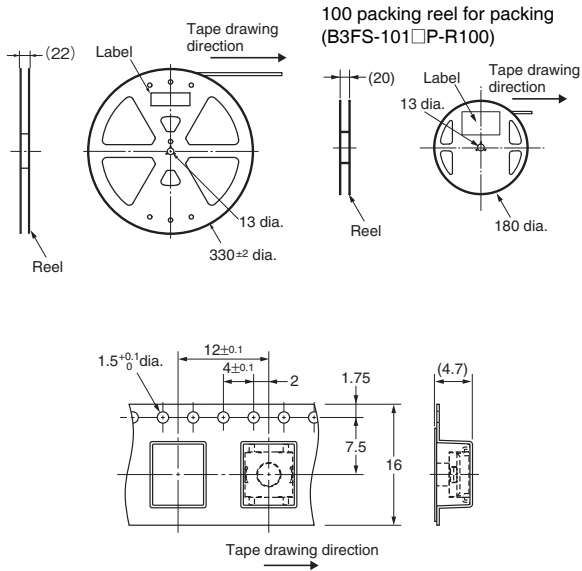

<b>Standards</b>	Conforms to JIS.
<b>Package</b>	1,000 Switches (B3FS-101□P) 100 Switches (B3FS-101□P-R100)

<B3FS-4002P/4005P>

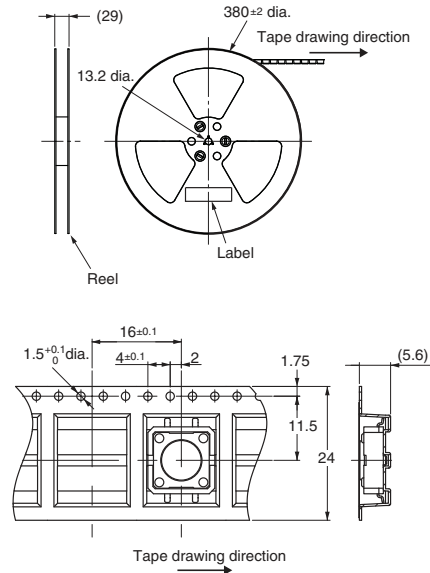

<b>Standards</b>	Conforms to JIS.
<b>Package</b>	1,000 Switches

<B3FS-4052P/4055P>

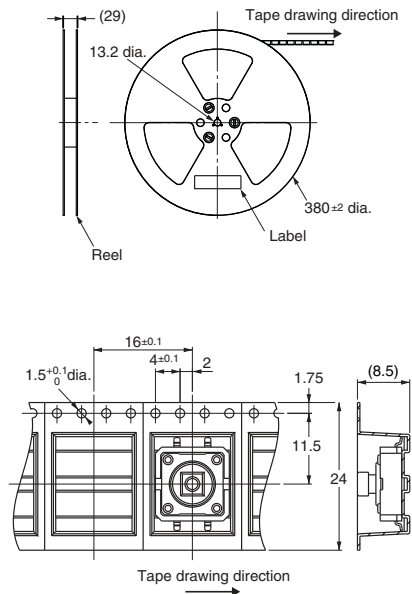

<b>Standards</b>	Conforms to JIS.
<b>Package</b>	500 Switches

<B3SL-1002P/1005P>

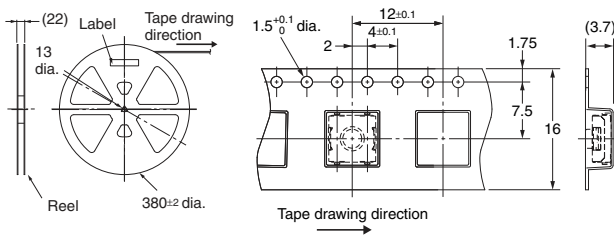

100 packing reel for packing (B3FS-100□P-R100)

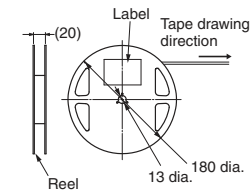

<B3SL-1022P/1025P>

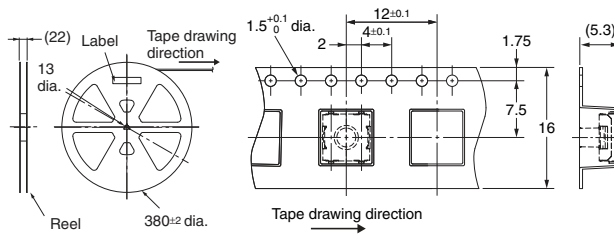

<b>Standards</b>	Conforms to JIS.
<b>Package</b>	2,000 Switches (B3SL-1002P/1005P) 1,400 Switches (B3SL-1022P/1025P)

<B3S>

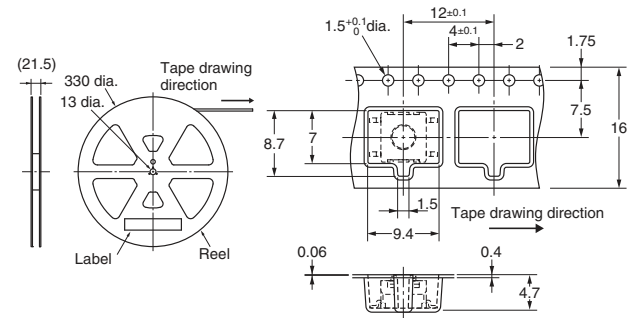

<b>Standards</b>	Conforms to JIS.
<b>Package</b>	1,000 Switches

**Note:** Switches with ground terminals are packaged with the ground terminal on the opposite side of the guide hole.

<B3U-1000 Series>

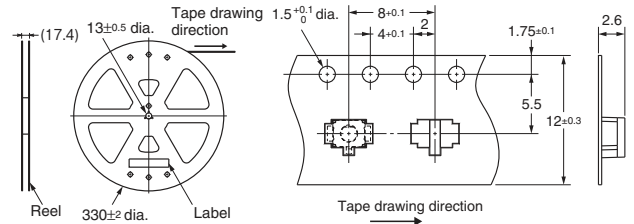

<B3U-3000 Series>

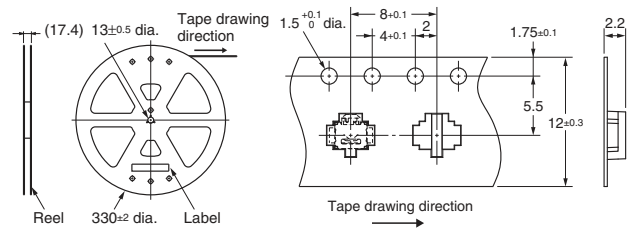

<b>Standards</b>	Conforms to JIS.
<b>Package</b>	3,500 Switches (B3U-1000 Series)
	4,000 Switches (B3U-3000 Series)
	1,000 Switches (B3U-□□□□PM Series)

<B3SE Series>

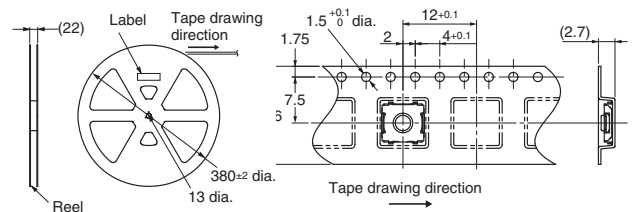

100 packing reel for packing (B3SE-1002P-R100)

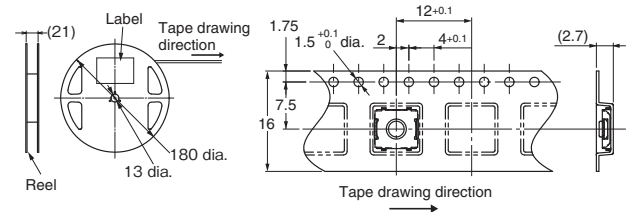

<b>Standards</b>	Conforms to JIS.
<b>Package</b>	2,000 Switches (B3SE-1002P)
	100 Switches (B3SE-1002P-R100)

### ● LEDs (B3J)

Make sure that the polarity of the LEDs is correct. The polarity is not indicated on the Switch, but the positive pole is located on the back surface of the Switch on the side without the OMRON mark. Connect limiting resistors to the LEDs. The Switch does not have built-in limiting resistors, so satisfy the LED characteristics by obtaining the limiting resistance according to the following formula based on the voltage to be used.

$$\text{Limiting resistance (R)} = \frac{\text{Voltage used (E) - LED forward voltage (VF)}}{\text{LED forward current (IF)}} \quad (\Omega)$$

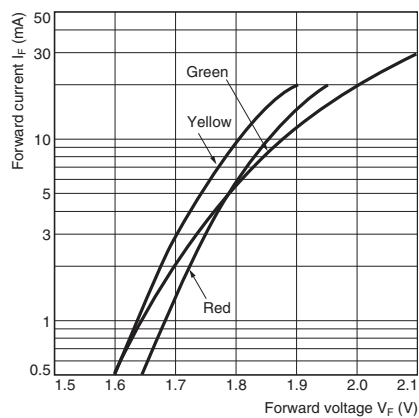
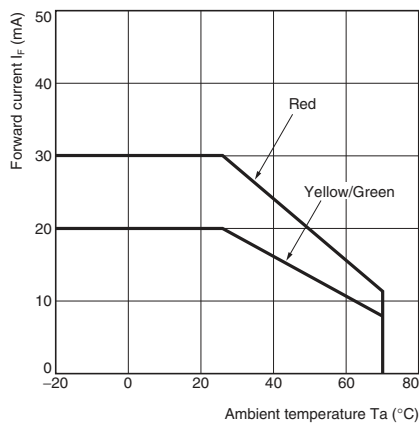
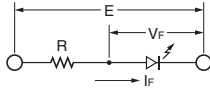

### ● RoHS Compliant

The "RoHS Compliant" designation indicates that the listed models do not contain the six hazardous substances covered by the RoHS Directive.

#### Reference:

The following standards are used to determine compliance for the six substances.

Lead:	1,000 ppm max.
Mercury:	1,000 ppm max.
Cadmium:	100 ppm max.
Hexavalent chromium:	1,000 ppm max.
PBB:	1,000 ppm max.
PBDE:	1,000 ppm max.

Please check each region's Terms & Conditions by region website.

---

**OMRON Corporation**  
Electronic and Mechanical Components Company

**Regional Contact**

**Americas**

<https://www.components.omron.com/>

**Asia-Pacific**

<https://ecb.omron.com.sg/>

**Korea**

<https://www.omron-ecb.co.kr/>

**Europe**

<http://components.omron.eu/>

**China**

<https://www.ecb.omron.com.cn/>

**Japan**

<https://www.omron.co.jp/ecb/>