

- ① MILITARY CONNECTORS USUALLY DESIGNATE A 3/4-20 THREAD FOR SIZE 14 CONNECTORS AND A 7/8-20 THREAD FOR SIZE 16 CONNECTORS. AMP'S SIZE 14 CONNECTORS WITH A 7/8-20 THREAD IS A DEVIATION FROM THIS STANDARD.
- ② BODY & CLAMPS: NICKEL PLATE.
- ③ BODY & CLAMPS: ZINC ALLOY.  
SCREWS & WASHERS: STAINLESS STEEL.
- ④ PACKAGED IN BULK ONLY.
- ⑤ OBSOLETE PARTS: OBSOLETE CIS STREAMLINING PER D.RENAUD/D.SINISI

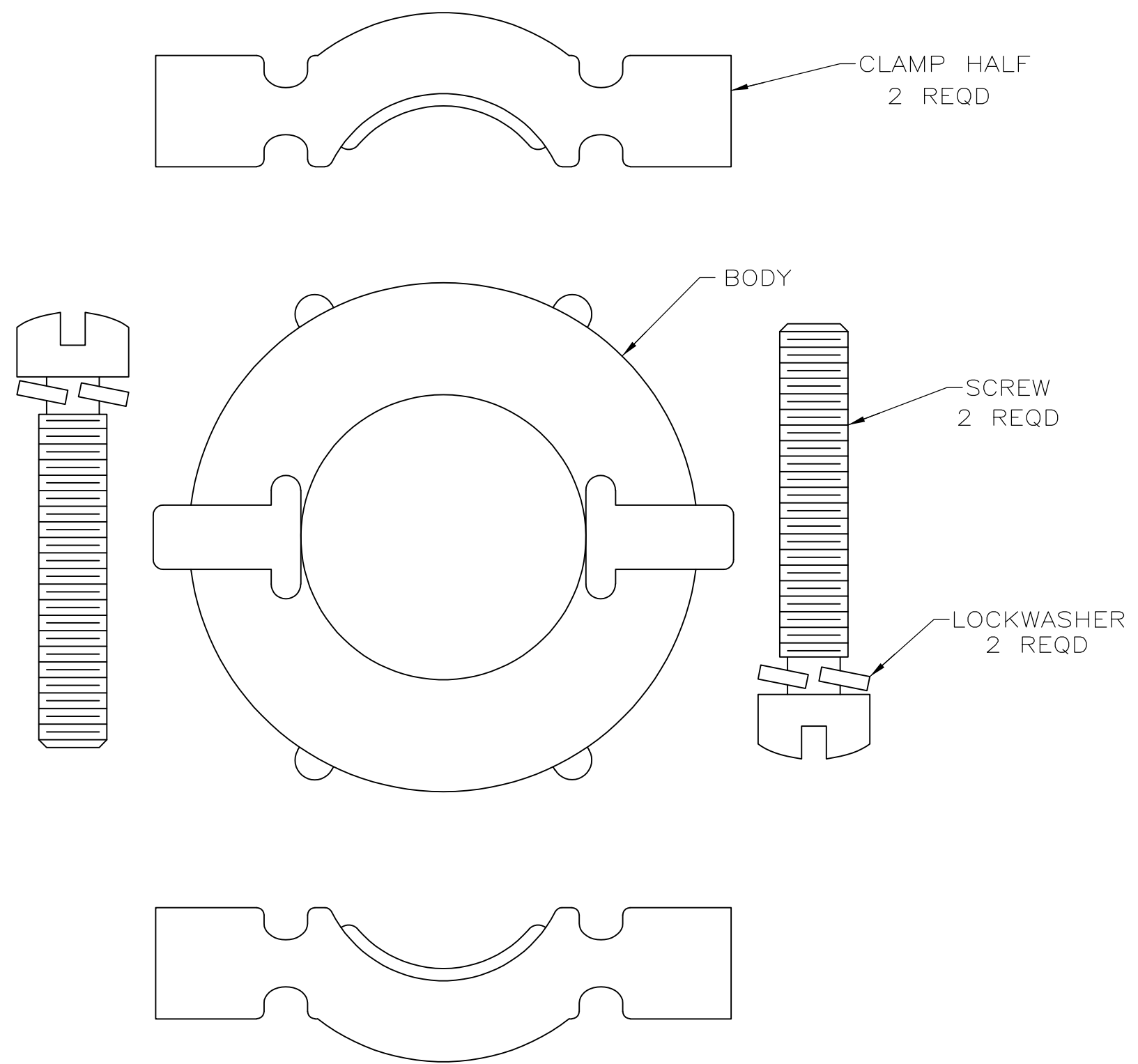

④	⑤	OBSOLETE	1	7/16-18UNEF-3B	11.43 [.450]	17.48 [.688]	42.88 [1.688]	43.10 [1.697]	26.19 [1.031]	28	1-208945-0
⑤		OBSOLETE	1	7/16-18UNEF-3B	11.43 [.450]	17.48 [.688]	42.88 [1.688]	43.10 [1.697]	26.19 [1.031]	28	-208945-9
			1	7/16-18UNEF-3B	11.43 [.450]	23.83 [.938]	42.88 [1.688]	43.10 [1.697]	26.19 [1.031]	28	208945-8
			1	3/16-18UNEF-3B	8.26 [.325]	19.05 [.750]	37.31 [1.469]	36.37 [1.432]	23.83 [.938]	22	208945-7
		①	1	7/8-20UNEF-3B	5.72 [.225]	14.27 [.562]	29.59 [1.165]	29.85 [1.175]	23.83 [.938]	14	208945-5
				F	E	D	C	B	A	SHELL SIZE	PART NO

THIS DRAWING IS A CONTROLLED DOCUMENT.

DWN W.G.LENKER 05/18/92  
CHK R.STONE 6-1-92  
APVD K.BEAVER 6-3-92

TE Connectivity

CABLE CLAMP KIT, UNASSEMBLED, CMC

SIZE A2 CAGE CODE 00779 DRAWING NO G-208945 RESTRICTED TO

MATERIAL ③ FINISH ② WEIGHT -

CUSTOMER DRAWING SCALE 4:1 SHEET 1 of 1 REV K2