

© - TE Connectivity. All Rights Reserved.

REVISIONS				
P	LTR	DESCRIPTION	DATE	APVD
	A	CHANGE REEL DEEPTH	28OCT2020	EZ DZ

- NOTE:
1. MATERIAL: COPPER ALLOY ,0.10±0.01mm THK.
  2. LEAD FREE
  3. 30u" MIN NI UNDERPLATING ALL OVER  
100u"(MIN.) Pure Matte Tin PLATING ON SOLDER AREA  
2u"(MIN.) GOLD ON CONTACT AREA
  4. RECOMMEND WORK RANG: 4.2mm~5.1mm

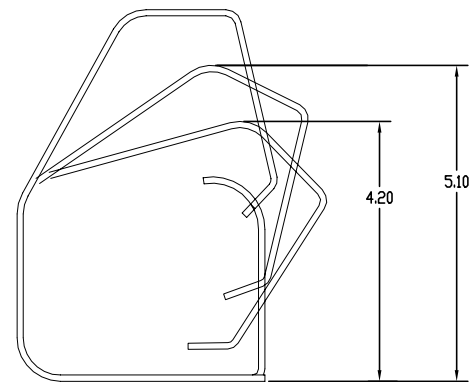
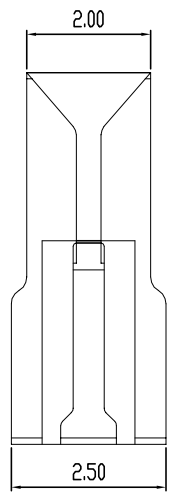
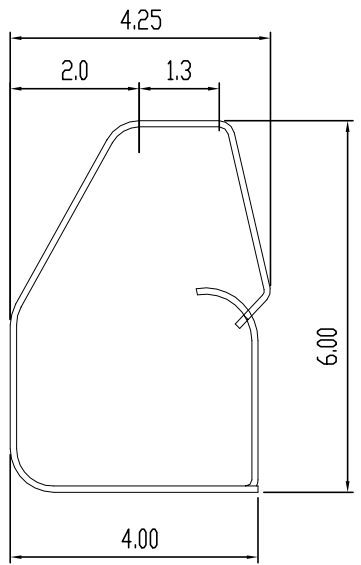
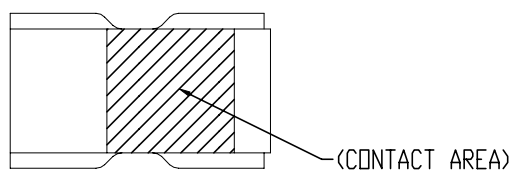

COMPRESSED DIM. (REFERENCE)

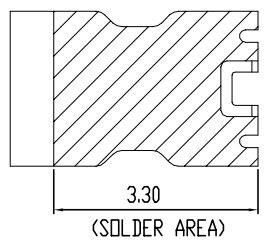

(SOLDER AREA)

2339640-1

THIS DRAWING IS A CONTROLLED DOCUMENT.		DWN	10JUL2018		TE Connectivity Ltd.		
		CHK	16JUN2018				
		APVD	16JUN2018		NAME		
DIMENSIONS:		TOLERANCES UNLESS OTHERWISE SPECIFIED:		PRODUCT SPEC			
mm				APPLICATION SPEC			
		0 PLC	± 0.3	WEIGHT			
		1 PLC	± 0.3	0			
		2 PLC	± 0.15	A3 00779			
		3 PLC	± 0.15	C=2339640			
		4 PLC	± -	SCALE 1:1			
		ANGLES	± -	SHEET 1 OF 2			
MATERIAL		FINISH		REV A			
-		-		CUSTOMER DRAWING			

REVISIONS					
P	LTR	DESCRIPTION	DATE	DWN	APVD
-	-	SEE SHEET 1	-	-	-

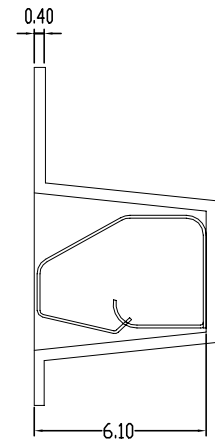
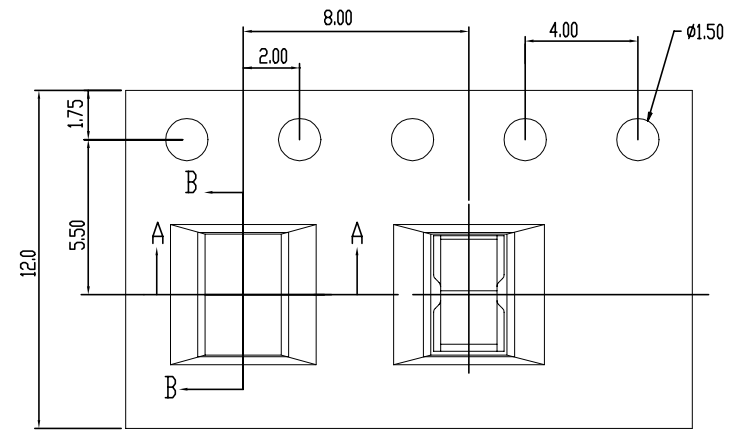

NOTE:

- 1. GENERAL TOLERANCE : ±0.3mm
- 2. PACKING STYLE : 1,400pcs/reel
- 3. MATERIAL :  
CARRIER TAPE : ACRYLIC FILM  
TOP TAPE : PET FILM  
REEL : PLASTIC

4. TAPES DIMENSION

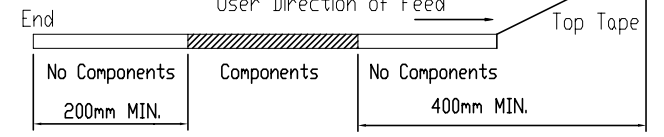

5. REEL DIMENSION : REFERENCE ONLY

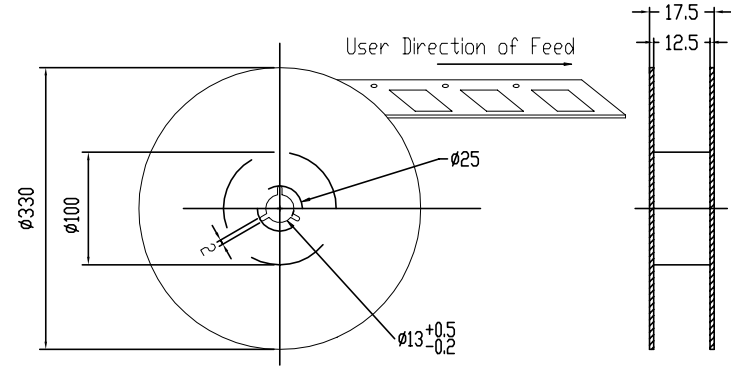
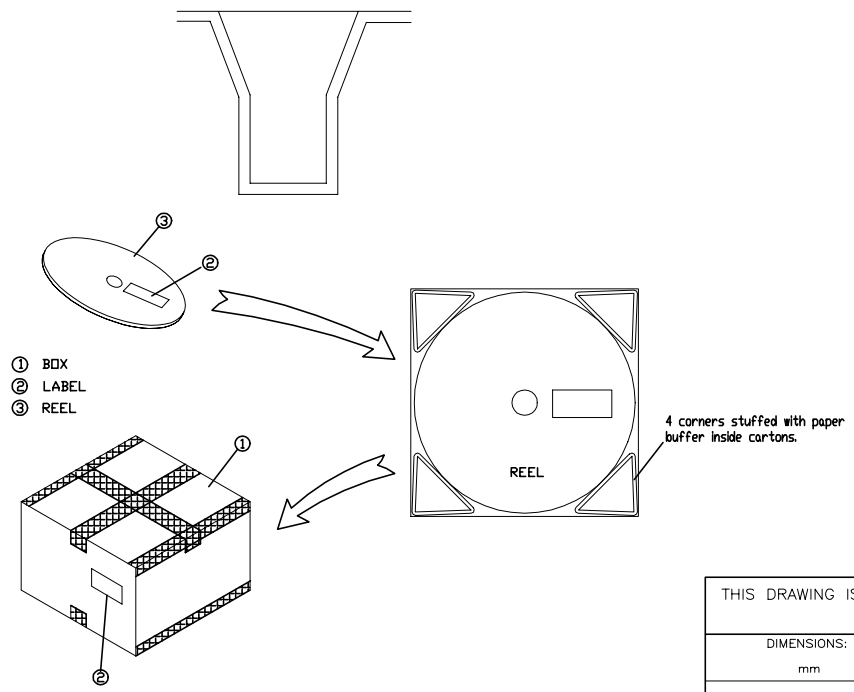

THIS DRAWING IS A CONTROLLED DOCUMENT.

DIMENSIONS:	TOLERANCES UNLESS OTHERWISE SPECIFIED:
mm	
	0 PLC ± 0.3
	1 PLC ± 0.3
	2 PLC ± 0.15
	3 PLC ± 0.15
	4 PLC ± -
	ANGLES ± -

MATERIAL	FINISH
-	-

DWN	10JUL2018
CHK	16JUN2018
APVD	16JUN2018
PRODUCT SPEC	-
APPLICATION SPEC	-
WEIGHT	-

<b>STE</b> TE Connectivity Ltd.	
NAME	
6.0 HEIGHT SPRING FINGER	
SIZE	CAGE CODE
A3	00779
DRAWING NO	RESTRICTED TO
C=2339640	-
CUSTOMER DRAWING	SCALE 1:1
SHEET 2 OF 2	REV A