

# TRF6903 SINGLE-CHIP MULTIBAND RF TRANSCEIVER

SWRS022D – MARCH 2004 – REVISED JUNE 2005

- Single-Chip RF Transceiver for 315-MHz, 433-MHz, 868-MHz, and 915-MHz Industrial, Scientific, and Medical (ISM) Bands
- 2.2-V to 3.6-V Operation
- Low Power Consumption
- FSK/OOK Operation
- Integer-N Synthesizer With Fully Integrated Voltage Controlled Oscillator (VCO)
- On-Chip Reference Oscillator and Phase-Locked Loop (PLL)
- Power Amplifier With 8-dBm Typical Output Power
- Programmable Brownout Detector
- Clock Recovery With Integrated Data Bit Synchronizer and Baud Rate Selection
- Linear Receive Strength Signal Indicator (RSSI)
- Flexible 3-Wire Serial Interface
- Minimal Number of External Components Required
- 48-Pin Low-Profile Plastic Quad Flat Package (PQFP)
- Programmable XTAL Trimming
- Lock Detect Indicator
- Programmable Training Sequence Recognition
- Pin Compatible to the TRF6901

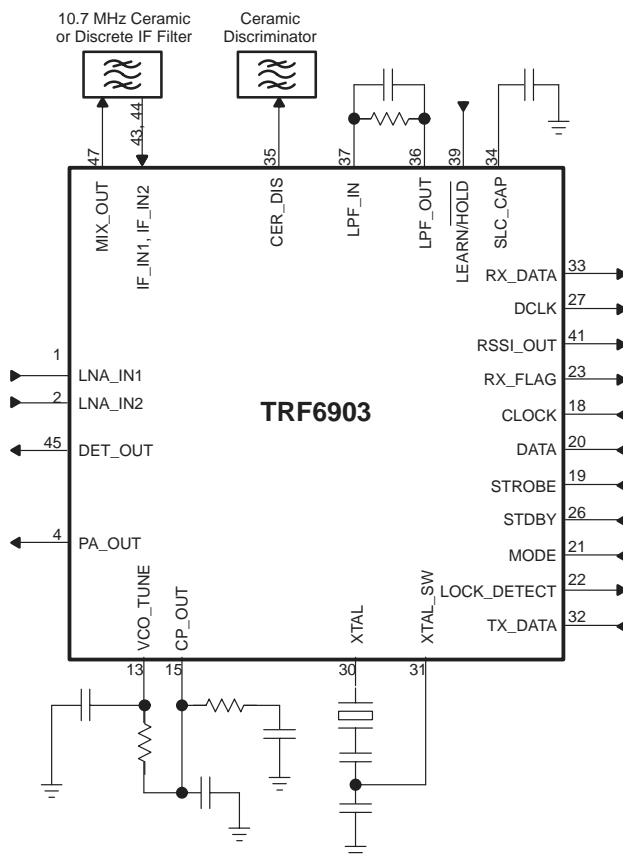

These devices have limited built-in ESD protection. The leads should be shorted together or the device placed in conductive foam during storage or handling to prevent electrostatic damage to the gates.



Please be aware that an important notice concerning availability, standard warranty, and use in critical applications of Texas Instruments semiconductor products and disclaimers thereto appears at the end of this data sheet.

PRODUCTION DATA information is current as of publication date. Products conform to specifications per the terms of Texas Instruments standard warranty. Production processing does not necessarily include testing of all parameters.



POST OFFICE BOX 655303 • DALLAS, TEXAS 75265

Copyright © 2005, Texas Instruments Incorporated

# TRF6903 SINGLE-CHIP MULTIBAND RF TRANSCEIVER

SWRS022D – MARCH 2004 – REVISED JUNE 2005

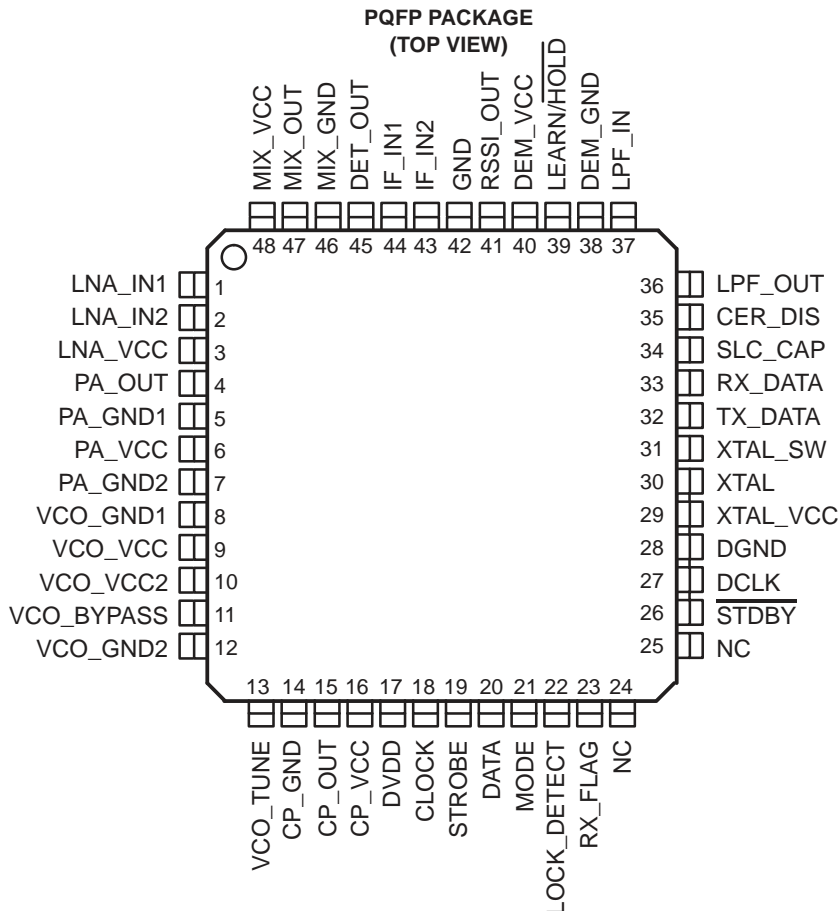

## description

The TRF6903 single-chip solution is an integrated circuit intended for use as a low-cost multiband FSK or OOK transceiver to establish a frequency-programmable, half-duplex, bidirectional RF link. The multichannel transceiver is intended for digital (FSK, OOK) modulated applications in the North American and European 315-MHz, 433-MHz, 868-MHz, and 915-MHz ISM bands. The single-chip transceiver operates down to 2.2 V and is designed for low power consumption. The synthesizer has a typical channel spacing of better than 200 kHz and features a fully-integrated VCO. Only the PLL loop filter is external to the device.

Two fully-programmable operation modes, Mode0 and Mode1, allow extremely fast switching between two preprogrammed settings (for example, receive (RX)/transmit (TX); TX\_frequency\_0/TX\_frequency\_1; RX\_frequency\_0/RX\_frequency\_1; ...) without reprogramming the device.

## ISM band standards

Europe has assigned an unlicensed frequency band of 868 MHz to 870 MHz. This band is specifically defined for short range devices with duty cycles from 0.1% to 100% in several subbands. The new European frequency band, due to the duty cycle assignment, allows a reliable RF link and makes many new applications possible.

The North American unlicensed ISM band covers 902 MHz to 928 MHz (center frequency of 915 MHz), and is suitable for short range RF links.



**transmitter**

The transmitter consists of an integrated VCO and tank circuit, a complete integer-N synthesizer, and a power amplifier. The dividers, prescaler, and reference oscillator require only the addition of an external crystal and a loop filter to provide a complete PLL with a typical frequency resolution of better than 200 kHz.

Since the typical RF output power is approximately 8 dBm, no additional external RF power amplifier is necessary in most applications.

Four attenuation settings for the power amplifier are offered. This feature allows the user to fine tune the amplifier for optimal output power.

**receiver**

The integrated receiver is intended to be used as a single-conversion FSK/OOK receiver. It consists of a low noise amplifier, mixer, limiter, FM/FSK demodulator with an external LC tank circuit or ceramic resonator, LPF amplifier, and a data slicer with clock recovery and an integrated data bit synchronizer. The received strength signal indicator (RSSI) can also be used for fast carrier sense on/off keying, or amplitude shift keying, (OOK/ASK) demodulator.

**baseband interface**

The TRF6903 can easily be interfaced to a baseband processor such as the Texas Instruments MSP430 ultralow-power microcontroller (see Figure 1). The TRF6903 serial control registers are programmed by the MSP430 and the MSP430 performs baseband operations in the software.

A synchronized data clock, programmable for most common data rates, is provided by the TRF6903. This feature reduces the need for extensive oversampling and data decision in the microcontroller during receive. During transmit, the data clock can be used to clock the transmit data from the microcontroller to the TRF6903 at predefined data rates.

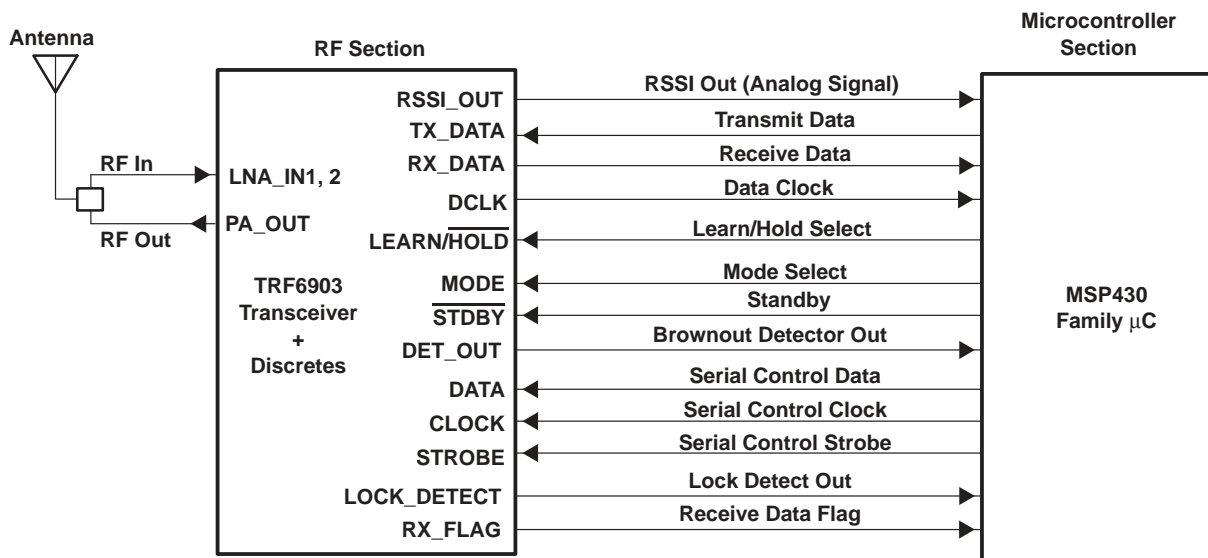
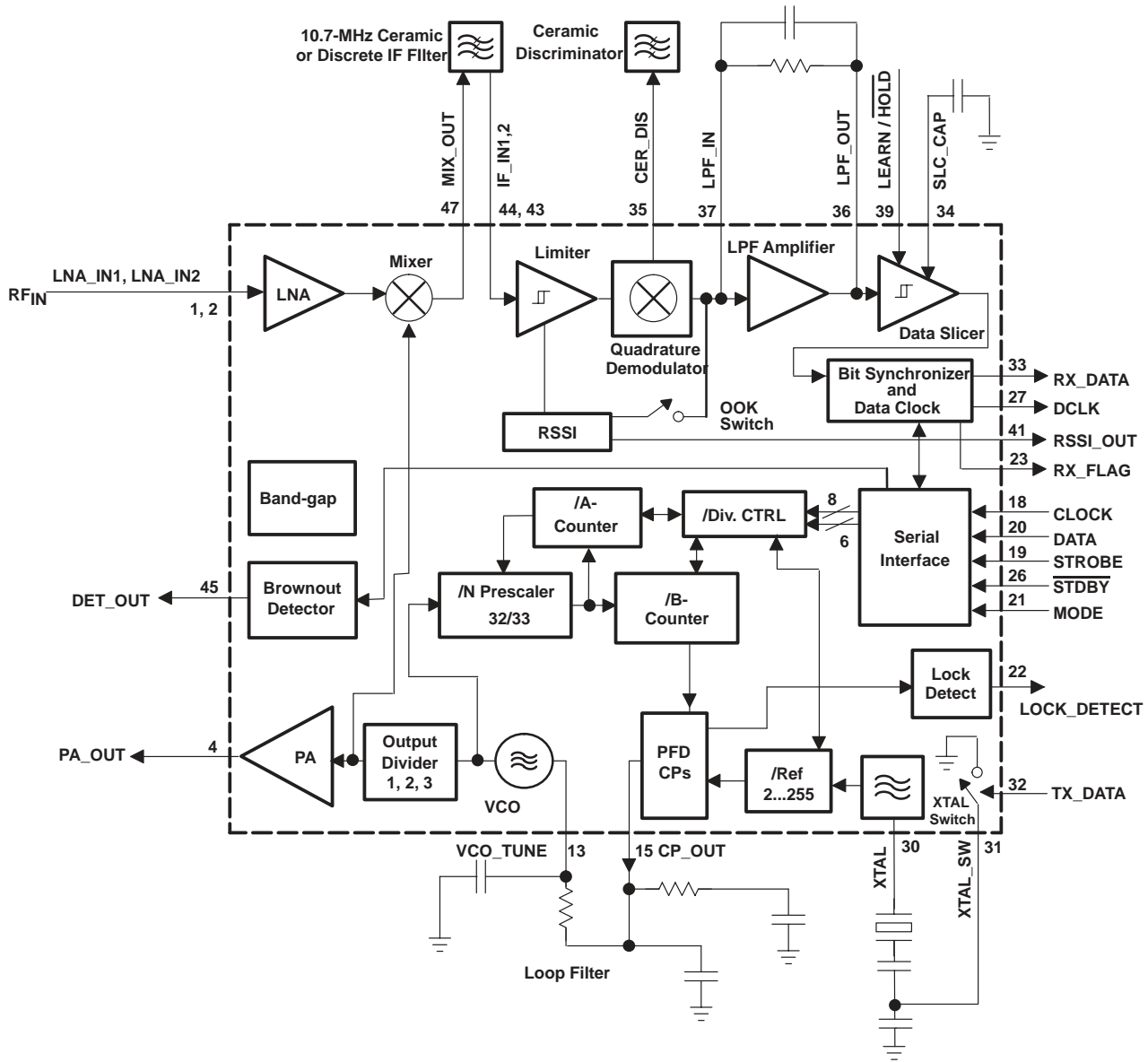

**Figure 1. System Block Diagram for Interfacing to the MSP430 Microcontroller**

# TRF6903 SINGLE-CHIP MULTIBAND RF TRANSCEIVER

SWRS022D – MARCH 2004 – REVISED JUNE 2005

## functional block diagram



### Terminal Functions

TERMINAL NAME	NO.	I/O	DESCRIPTION
CER_DIS	35		Connect to external ceramic discriminator
CLOCK	18	I	Serial interface clock signal input
CP_GND	14		Charge pump ground
CP_OUT	15	O	Charge pump output
CP_VCC	16		Charge pump supply voltage
DATA	20	I	Serial interface data signal input

# TRF6903 SINGLE-CHIP MULTIBAND RF TRANSCEIVER

SWRS022D – MARCH 2004 – REVISED JUNE 2005

## Terminal Functions (Continued)

TERMINAL		I/O	DESCRIPTION
NAME	NO.		
DCLK	27	O	Data clock output
DEM_GND	38		Demodulator ground
DEM_VCC	40		Demodulator supply voltage
DET_OUT	45	O	Brownout detector output; active high
DGND	28		Digital ground
DVDD	17		Digital power supply
GND	42		Substrate ground
IF_IN1	44	I	Limiter amplifier noninverting input
IF_IN2	43	I	Limiter amplifier inverting input
LEARN/HOLD	39	I	Data slicer switch. Controls data slicer reference level
LNA_IN1	1	I	LNA noninverting input
LNA_IN2	2	I	LNA inverting input
LNA_VCC	3		LNA power supply
LOCK_DETECT	22	O	PLL lock detect signal, active high
LPF_IN	37	I	Low-pass filter amplifier input
LPF_OUT	36	O	Low-pass filter amplifier output
MIX_GND	46		Mixer ground
MIX_OUT	47	O	Mixer output
MIX_VCC	48		Mixer supply voltage
MODE	21	I	Mode select input
NC	24, 25		No connect
PA_GND1	5		Power amplifier ground
PA_GND2	7		Power amplifier ground
PA_OUT	4	O	Power amplifier output
PA_VCC	6		Power amplifier supply voltage
RSSI_OUT	41	O	RSSI output signal
RX_DATA	33	O	Demodulated digital (FSK or OOK) RX data
RX_FLAG	23	O	Receive data flag
SLC_CAP	34	I/O	External capacitor for data slicer
STDBY	26	I	Standby input signal; active low
STROBE	19	I	Serial interface strobe signal
TX_DATA	32	I	Buffered TX data input
VCO_BYPASS	11	I	VCO bypass; connect to ground through a 100-pF capacitor
VCO_GND1	8		VCO ground
VCO_GND2	12		VCO ground
VCO_TUNE	13	I	Tuning voltage for the integrated VCO
VCO_VCC	9		VCO supply voltage
VCO_VCC2	10		VCO core supply voltage
XTAL	30	I/O	Connection to an external crystal reference
XTAL_SW	31	I	Connecting to external capacitor, which sets the frequency deviation of the transmitted signal
XTAL_VCC	29		Oscillator supply voltage



# TRF6903 SINGLE-CHIP MULTIBAND RF TRANSCEIVER

SWRS022D – MARCH 2004 – REVISED JUNE 2005

## absolute maximum ratings over operating free-air temperature (unless otherwise noted)†

Supply voltage range	–0.6 to 4.5 Vdc
Input voltage, logic signals	–0.6 to 4.5 Vdc
Storage temperature range, $T_{stg}$	–65°C to 150°C
ESD protection, human body model (HBM)	2 kV

† Stresses beyond those listed under “absolute maximum ratings” may cause permanent damage to the device. These are stress ratings only, and functional operation of the device at these or any other conditions beyond those indicated under “recommended operating conditions” is not implied. Exposure to absolute-maximum-rated conditions for extended periods may affect device reliability.

## recommended operating conditions

PARAMETER	TEST CONDITIONS	MIN	TYP	MAX	UNIT
Analog supply voltage		2.2		3.6	V
Digital supply voltage		2.2		3.6	V
Operating free-air temperature		–40		85	°C

## dc electrical characteristics, $V_{CC} = 2.7\text{ V}$ , $T_A = 25^\circ\text{C}$

### supply current

PARAMETER	TEST CONDITIONS	MIN	TYP	MAX	UNIT
Standby current	STDBY low		0.6	4	$\mu\text{A}$
RX current, receive chain inactive. Bit synchronizer and data clock inactive. PLL, VCO, dividers, and reference active	315-MHz band		12	15	mA
	433-MHz band		11	14	
	868-MHz band		10	12	
	915-MHz band		10	12	
RX current, receive chain active. PLL, VCO, dividers, and reference active. Bit synchronizer and data clock inactive	315-MHz band		20	26	mA
	433-MHz band		19	25	
	868-MHz band		18	23	
	915-MHz band		18	23	
RX current, receive chain active. PLL, VCO, dividers, and reference active. Bit synchronizer and data clock active	315-MHz band		20	26	mA
	433-MHz band		19	25	
	868-MHz band		18	23	
	915-MHz band		18	23	



**dc electrical characteristics,  $V_{CC} = 2.7\text{ V}$ ,  $T_A = 25^\circ\text{C}$  (continued)**

**supply current (continued)**

PARAMETER		TEST CONDITIONS	MIN	TYP	MAX	UNIT
TX current, PA disabled. PLL, VCO, dividers, and reference active		315-MHz band		12	15	mA
		433-MHz band		11	14	
		868-MHz band		10	12	
		915-MHz band		10	12	
TX current <sup>‡</sup> , PA enabled. PLL, VCO, dividers, reference, and data clock active	0-dB attenuation	315-MHz band		37	43	mA
	10-dB attenuation	315-MHz band		30		
	20-dB attenuation	315-MHz band		29		
	0-dB attenuation	433-MHz band		36	42	
	10-dB attenuation	433-MHz band		29		
	20-dB attenuation	433-MHz band		28		
	0-dB attenuation	868-MHz band		35	40	
	10-dB attenuation	868-MHz band		28		
	20-dB attenuation	868-MHz band		27		
	0-dB attenuation	915-MHz band		35	40	
	10-dB attenuation	915-MHz band		28		
	20-dB attenuation	915-MHz band		27		

<sup>‡</sup> The TX current consumption is dependent upon the external PA matching circuit. The matching network is normally designed to achieve the highest output power at the 0-dB attenuation setting. Changing the external matching components to optimize the output power for other attenuation settings alters the typical current consumption from the typical values noted.

**digital interface**

PARAMETER		TEST CONDITIONS	MIN	TYP	MAX	UNIT
$V_{IH}$	High-level input voltage		$V_{DD}-0.4$		$V_{DD}$	V
$V_{IL}$	Low-level input voltage		0		0.4	V
$V_{OH}$	High-level output voltage	$I_{OH} = 0.5\text{ mA}$	$V_{DD}-0.4$			V
$V_{OL}$	Low-level output voltage	$I_{OL} = 0.5\text{ mA}$			0.4	V
Digital input leakage current				<0.01		$\mu\text{A}$

**ac electrical characteristics,  $V_{CC} = 2.7\text{ V}$ ,  $T_A = 25^\circ\text{C}$**

**receiver (LNA, mixer, limiter, demod, LPF amplifier, data slicer, VCO, and PLL)**

PARAMETER		TEST CONDITIONS	MIN	TYP	MAX	UNIT
RX wake-up time					1	ms
BER, FSK		315 MHz, 433 MHz, 868 MHz, 915 MHz, IF = 10.7 MHz, BW = 280 kHz FSK deviation: $\pm 32\text{ kHz}$ Bit rate: 19.2 kbit/s Manchester <sup>†</sup> $-103 < P_{RFIN}\text{ (dBm)} < -30$		$10^{-3}$		
BER, OOK		315 MHz, 433 MHz, 868 MHz, 915 MHz, IF = 10.7 MHz, BW = 280 kHz ON-OFF ratio: 50 dB Bit rate: 9.6 kbit/s Manchester <sup>‡</sup> $-103 < P_{RFIN}\text{ (dBm)} < -30$		$10^{-3}$		

<sup>†</sup> 19.2 kbit/s Manchester is equivalent to 38.4 kbit/s NRZ.

<sup>‡</sup> 9.6 kbit/s Manchester is equivalent to 19.2 kbit/s NRZ.

# TRF6903 SINGLE-CHIP MULTIBAND RF TRANSCEIVER

SWRS022D – MARCH 2004 – REVISED JUNE 2005

ac electrical characteristics,  $V_{CC} = 2.7\text{ V}$ ,  $T_A = 25^\circ\text{C}$

## LNA/mixer, 304–316 MHz

PARAMETER	TEST CONDITIONS	MIN	TYP	MAX	UNIT
Frequency range		304	315	316	dB
Conversion gain			21		dB
SSB noise figure	Includes external matching network		6.5		dB
Input 1-dB compression point			-31		dBm
Input IP3			-21		dBm

## LNA/mixer, 430–450 MHz

PARAMETER	TEST CONDITIONS	MIN	TYP	MAX	UNIT
Frequency range		430	433	450	MHz
Conversion gain			21		dB
SSB noise figure	Includes external matching network		6.5		dB
Input 1-dB compression point			-31		dBm
Input IP3			-21		dBm

## LNA/mixer, 868–870 MHz

PARAMETER	TEST CONDITIONS	MIN	TYP	MAX	UNIT
Frequency range		868	869	870	MHz
Conversion gain			19		dB
SSB noise figure	Includes external matching network		6.5		dB
Input 1-dB compression point			-31		dBm
Input IP3			-20		dBm

## LNA/mixer, 902–928 MHz

PARAMETER	TEST CONDITIONS	MIN	TYP	MAX	UNIT
Frequency range		902	915	928	MHz
Conversion gain			18		dB
SSB noise figure	Includes external matching network		6.5		dB
Input 1-dB compression point			-31		dBm
Input IP3			-19		dBm

## IF/limiter amplifier

PARAMETER	TEST CONDITIONS	MIN	TYP	MAX	UNIT
Frequency			10.7		MHz
Voltage gain			86		dB
Noise figure	IF frequency = 10.7 MHz		4		dB

## VCO/output divider

PARAMETER	TEST CONDITIONS	MIN	TYP	MAX	UNIT
Frequency range: 315-MHz band	Low-side injection, $A_{<1:0>} = 11$	304	315	316	MHz
Frequency range: 433-MHz band	High-side injection, $A_{<1:0>} = 10$	430	433	450	MHz
Frequency range: 868-MHz band	High-side injection, $A_{<1:0>} = 01$	868	869	870	MHz
Frequency range: 915-MHz band	Low-side injection, $A_{<1:0>} = 01$	902	915	928	MHz
Closed loop phase noise	Frequency offset = 50 kHz		-77		dBc/Hz
	Frequency offset = 200 kHz		-90		
Tuning voltage		0.1	$V_{CC}$ at terminal 10		V





# TRF6903 SINGLE-CHIP MULTIBAND RF TRANSCEIVER

SWRS022D – MARCH 2004 – REVISED JUNE 2005

## ac electrical characteristics, $V_{CC} = 2.7\text{ V}$ , $T_A = 25^\circ\text{C}$ (continued)

### RSSI

PARAMETER	TEST CONDITIONS	MIN	TYP	MAX	UNIT
Dynamic range			70		dB
Rise time	$R_L = 100\text{ k}\Omega$ , $C_L = 10\text{ pF}$		2	4	$\mu\text{s}$
Slope			20		mV/dB
RSSI output current	$R_L = 100\text{ k}\Omega$ , $C_L = 10\text{ pF}$		30		$\mu\text{A}$

### impedances and loads

PARAMETER	TEST CONDITIONS	MIN	TYP	MAX	UNIT
LNA_IN		See Figure 4			
MIX_OUT†			1400		$\Omega$
IF_IN†	Differential		2600		$\Omega$
PA_OUT		See Figure 10			

† Does not include external matching network.

### transmitter (XTAL, PLL, VCO, and PA), 315-MHz band

PARAMETER	TEST CONDITIONS	MIN	TYP	MAX	UNIT
TX frequency range	$A<1:0> = 11$	304	315	316	MHz
Output power†	0-dB attenuation		8		dBm
	10-dB attenuation		-2		
	20-dB attenuation		-12		
	Disabled, $B<3> = 0$		-80		
	Off‡		-80		
Second harmonic			-25		dBc
Third harmonic			-30		dBc
Frequency deviation§	FSK		$\pm 32$		kHz
Power ON-OFF ratio	OOK, 0-dB mode		75		dB
Maximum data rate (NRZ)	FSK		64		kbit/s
	OOK		32		

† Matched to  $50\ \Omega$  using external matching network.

‡ Not selectable with PA attenuation bits  $A<7:6>$ ,  $B<7:6>$ , or with  $B<3>$ . Measured while the TRF6903 device is in RX mode.

§ Dependent upon external circuitry.



# TRF6903 SINGLE-CHIP MULTIBAND RF TRANSCEIVER

SWRS022D – MARCH 2004 – REVISED JUNE 2005

ac electrical characteristics,  $V_{CC} = 2.7\text{ V}$ ,  $T_A = 25^\circ\text{C}$  (continued)

## transmitter (XTAL, PLL, VCO, and PA), 433-MHz band

PARAMETER	TEST CONDITIONS	MIN	TYP	MAX	UNIT
TX frequency range	A<1:0> = 10	430	433	450	MHz
Output power†	0-dB attenuation		8		dBm
	10-dB attenuation		-2		
	20-dB attenuation		-12		
	Disabled, B<3> = 0		-80		
	Off‡		-80		
Second harmonic			-25		dBc
Third harmonic			-30		dBc
Frequency deviation§	FSK		±32		kHz
Power ON-OFF ratio	OOK, 0-dB mode		75		dB
Maximum data rate (NRZ)	FSK		64		kbit/s
	OOK		32		

† Matched to 50  $\Omega$  using external matching network.

‡ Not selectable with PA attenuation bits A<7:6>, B<7:6>, or with B<3>. Measured while the TRF6903 device is in RX mode.

§ Dependent upon external circuitry.

## transmitter (XTAL, PLL, VCO, and PA), 868-MHz band

PARAMETER	TEST CONDITIONS	MIN	TYP	MAX	UNIT
TX frequency range	A<1:0> = 11	868	869	870	MHz
Output power†	0-dB attenuation		8		dBm
	10-dB attenuation		-2		
	20-dB attenuation		-12		
	Disabled, B<3> = 0		-80		
	Off‡		-80		
Second harmonic			-25		dBc
Third harmonic			-30		dBc
Frequency deviation§	FSK		±32		kHz
Power ON-OFF ratio	OOK, 0-dB mode		75		dB
Maximum data rate (NRZ)	FSK		64		kbit/s
	OOK		32		

† Matched to 50  $\Omega$  using external matching network.

‡ Not selectable with PA attenuation bits A<7:6>, B<7:6>, or with B<3>. Measured while the TRF6903 device is in RX mode.

§ Dependent upon external circuitry.



ac electrical characteristics,  $V_{CC} = 2.7\text{ V}$ ,  $T_A = 25^\circ\text{C}$  (continued)

transmitter (XTAL, PLL, VCO, and PA), 915-MHz band

PARAMETER	TEST CONDITIONS	MIN	TYP	MAX	UNIT
TX frequency range	A<1:0> = 11	902	915	928	MHz
Output power†	0-dB attenuation		8		dBm
	10-dB attenuation		-2		
	20-dB attenuation		-12		
	Disabled, B<3> = 0		-80		
	Off‡		-80		
Second harmonic			-25		dBc
Third harmonic			-30		dBc
Frequency deviation§	FSK		±32		kHz
Power ON-OFF ratio	OOK, 0-dB mode		75		dB
Maximum data rate (NRZ)	FSK		64		kbit/s
	OOK		32		

† Matched to 50  $\Omega$  using external matching network.

‡ Not selectable with PA attenuation bits A<7:6>, B<7:6>, or with B<3>. Measured while the TRF6903 device is in RX mode.

§ Dependent upon external circuitry.

#### XTAL

PARAMETER	TEST CONDITIONS	MIN	TYP	MAX	UNIT
Frequency range		9.5		20	MHz

#### brownout detector

PARAMETER	TEST CONDITIONS	MIN	TYP	MAX	UNIT
Voltage threshold, $V_{det}$	Set by B<2:1>	2.2		2.8	V
Voltage steps ( $\Delta V$ )			200		mV
Number of steps			4		
Output level	Connected to typical input port of microcontroller		CMOS		

# TRF6903 SINGLE-CHIP MULTIBAND RF TRANSCEIVER

SWRS022D – MARCH 2004 – REVISED JUNE 2005

## timing data for serial interface

PARAMETER		MIN	TYP	MAX	UNIT
$f(\text{CLOCK})$	Clock frequency			20	MHz
$t_w(\text{CLKHI})$	Clock high-time pulse width, clock high		20		ns
$t_w(\text{CLKLO})$	Clock low-time pulse width, clock low		20		ns
$t_{su}(\text{D})$	Setup time, data valid before CLOCK $\uparrow$		0		ns
$t_h(\text{D})$	Hold time, data valid after CLOCK $\uparrow$		10		ns
$t_d(\text{CLKLO})$	Delay time of CLOCK low before STROBE high		20		ns
$t_w(\text{STROBEHI})$	STROBE high-time pulse width, STROBE high		20		ns
$t_w(\text{STROBELO})$	STROBE low-time pulse width, STROBE low		20		ns

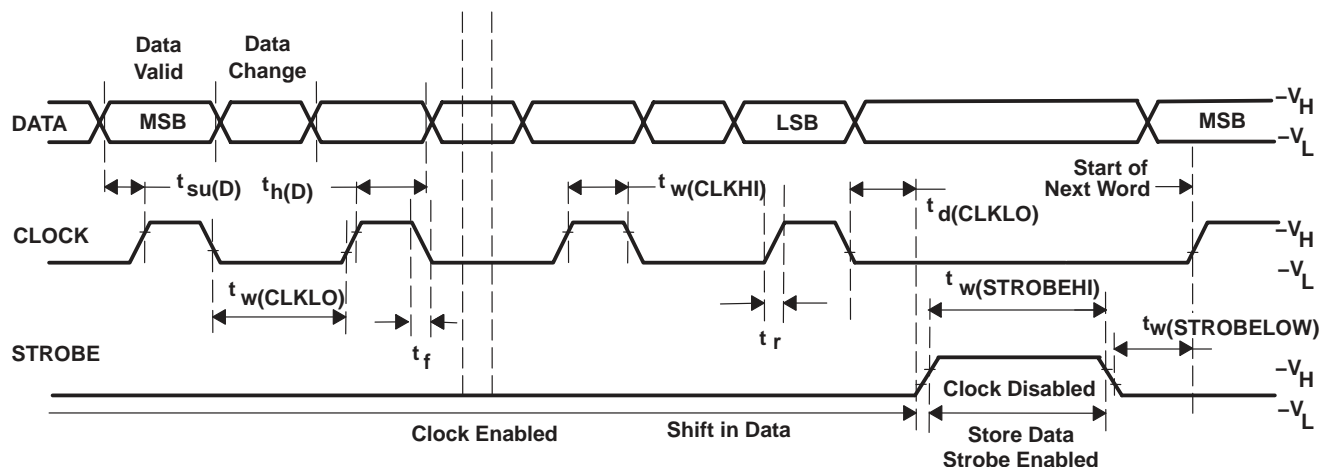

Note: Most significant bit (MSB) clocked in first to the synthesizer.

Figure 2. Timing Data for Serial Interface

timing data for DCLK, TX\_DATA, RX\_FLAG, and RX\_DATA

PARAMETER		MIN	TYP	MAX	UNIT
$t_{d(DG)}$	Delay time, rising edge of DCLK to transition of RX_DATA		3		ns
$t_{su(r)}$	Setup time, RX_DATA valid before DCLK $\uparrow$	$0.4/f_c^\dagger$			
$t_{h(r)}$	Hold time, RX_DATA valid after DCLK $\uparrow$	$0.4/f_c^\dagger$			
$t_{d(FK)}$	Delay time, rising edge of RX_FLAG before DCLK $\uparrow$		2		ns
$t_{su(TX)}$	Setup time, TX_DATA valid before DCLK $\uparrow$	100			ns
$t_{h(TX)}$	Hold time, TX_DATA valid after DCLK $\uparrow$	100			ns

$\dagger$  After clock recovered

Receive Deglitch Mode

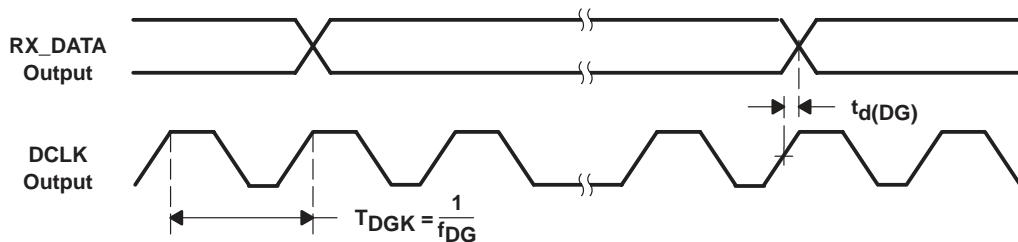

Receive Clock Recovery Mode or Self Train Mode

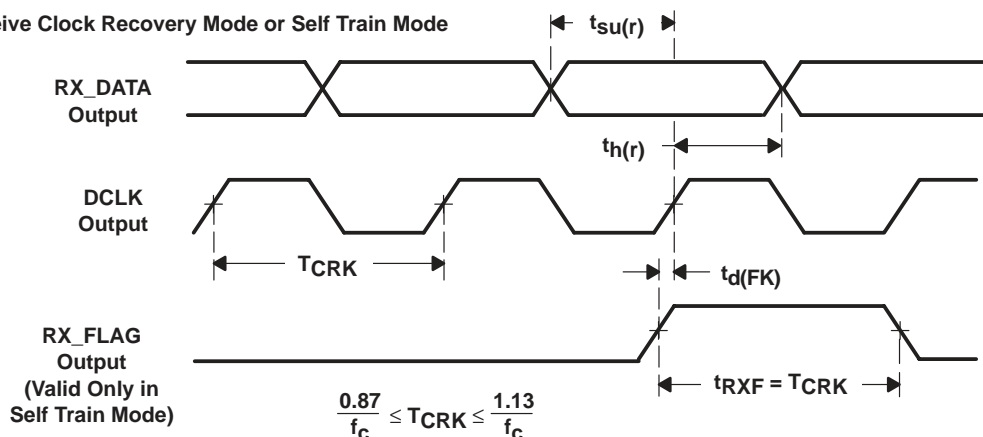

NOTE: RX\_DATA is latched at the falling edge of DCLK.

Transmit

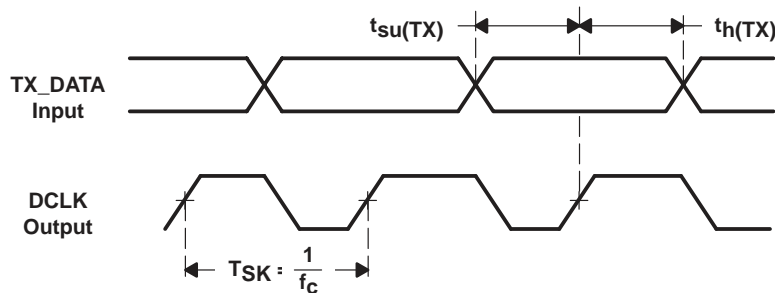

NOTE: TX\_DATA is latched at the rising edge of DCLK.

Figure 3. Timing Data for DCLK, TX\_DATA, RX\_FLAG, and RX\_DATA

It can be seen from the timing diagram that in the clock recovery or self train mode, the data transitions (high-to-low or low-to-high) on the RXDATA pin are timed to coincide with the falling edge of DCLK. Any microcontroller using the TRF6903 can then latch RXDATA on the rising edge of DCLK. For more details, see the *data clock* section.

# TRF6903 SINGLE-CHIP MULTIBAND RF TRANSCEIVER

SWRS022D – MARCH 2004 – REVISED JUNE 2005

## timing data for DCLK, TX\_DATA, RX\_FLAG, and RX\_DATA (continued)

In high data rate systems (> 38K bps), designers need to be aware of the latency between the rising edge of DCLK and the time the RXDATA logic value is sampled by the microcontroller. This latency needs to be less than half the RXDATA pulse width to prevent bit errors.

If transmit capture mode is selected (by setting bit 13 in word E), the data transitions (high-to-low or low-to-high) on the TXDATA pin are timed to coincide with the falling edge of DCLK. Any microcontroller using the TRF6903 can then latch TXDATA on the rising edge of DCLK. For more details, see the *data clock* section.

## low-noise amplifier (LNA)/RF mixer

The LNA has differential inputs. The off-chip input matching network has the dual task of matching a 50-Ω connector (or antenna, switch, filter, etc.) to the differential inputs and providing a 180-degree phase shift between the inputs at terminals 1 and 2. The differential input impedance of the LNA is approximately 500 Ω in parallel with 0.7 pF. The predicted noise figure of the LNA and input matching circuit is 2.5 dB. The cascaded noise figure for the LNA/mixer is listed in the specifications.

The mixer offers good linearity (high IP3). An external matching network is required to transform the output impedance of the mixer (1.4 kΩ) to the input impedance of the IF filter (typically 330 Ω).

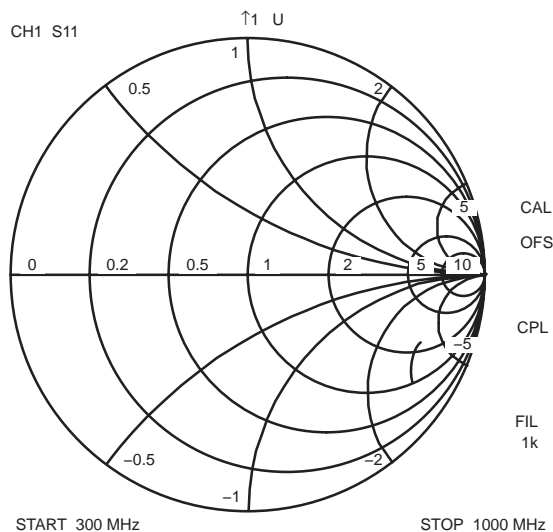

Figure 4. Typical LNA Input Impedance (S11) at Device Terminals LNA\_IN1,2

## IF amplifier/limiter

The IF amplifier has differential inputs to its first stage. The limiting amplifier provides 68 dB of gain. An external impedance matching network is required between the IF filter output at terminal 47 and the IF amplifier inputs at terminals 43 and 44.

## RSSI

The received signal strength indicator (RSSI) voltage at terminal 41 is proportional to the log of the down-converted RF signal at the IF limiting amplifier input. The RSSI circuit is temperature compensated. It is useful for detecting interfering signals, transceiver handshaking, and RF channel selection. In some applications, the RSSI circuitry alone can be used as a demodulator for amplitude-shift keying (ASK) or on-off keying (OOK) modulation with an output at the RSSI\_OUT terminal. In OOK mode, the received signal is also fed from the RSSI circuitry to the input of the post-detection LPF amplifier. In this mode, received data is output at the RX\_DATA terminal according to the RXM field.

**demodulator**

The quadrature demodulator decodes digital frequency shift keying (FSK) modulation. An external ceramic discriminator or an equivalent discrete circuit is required at terminal 35. The demodulator is optimized for use with a ceramic discriminator. Thus, the use of a packaged ceramic discriminator is recommended for best performance. Internal resistors can be programmed with D<14:12> to tune the demodulator center frequency. The recommended default setting for the demodulator tuning bits is D<14:12> = 110. The resonant frequency of the discrete-component discriminator can be calculated from the inductor and capacitor values used in the circuit. A parallel resistor may be added to reduce the quality factor (Q) of the tank circuit, depending on the application.

When OOK modulation is selected, the received signal from the RSSI circuitry is connected directly to the post-detection LPF amplifier, therefore bypassing the quadrature demodulator.

$$f_{res} = \frac{1}{2\pi\sqrt{LC}}$$

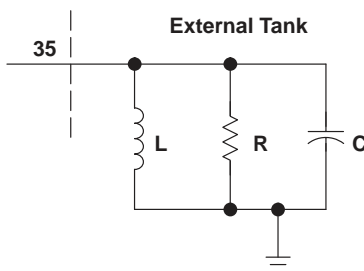
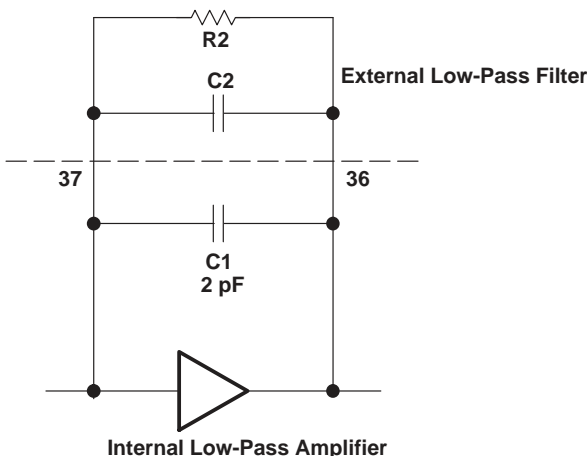

**Figure 5. Optional External Discrete Demodulator Tank**

**post-detection amplifier/low-pass filter**

The post-detection amplifier operates as a low-pass transimpedance amplifier. The external low-pass filter circuit must be optimized for the data rate. The 3-dB corner frequency of the low-pass filter should be greater than twice the data rate. Various low-pass filter designs use two to five components and may be first- or second-order designs. Simple 2-element filter component values and 3-dB bandwidths are contained in Table 1.

$$f_{3dB} = \frac{1}{2\pi R2(C2 + C1)}$$



**Figure 6. Post-Detection Amplifier/Low-Pass Filter**

# TRF6903 SINGLE-CHIP MULTIBAND RF TRANSCEIVER

SWRS022D – MARCH 2004 – REVISED JUNE 2005

## post-detection amplifier/low-pass filter (continued)

**Table 1. Various Post-Detection Amplifier/Low-Pass Filter  
3-dB Bandwidth and Corresponding Component Values for FSK Operation**

f <sub>3dB</sub> (kHz)	10	20	30	60
R2 (kΩ)	220	220	220	220
C2 (pF)	68	33	22	10

NOTE: For OOK operation, it is recommended that R2 be set to 27 kΩ and C2 is not placed.

## data slicer and bit synchronizer

The data slicer is a comparator circuit for received digital (FSK and OOK) data. The data slicer output voltage depends on the difference between the received signal and a reference voltage (at the sample-and-hold (S&H) capacitor) used as a decision threshold. During the learn mode, the S&H capacitor connected to terminal 34 is charged up to the average dc voltage of a training sequence of alternating ones and zeroes; this establishes the reference voltage to be used as a decision level before a sequence of actual data is received in the hold mode. During long data transmissions, more training sequences may be necessary to recharge the S&H capacitor.

If the modulation scheme is dc-free (Manchester coding) or constant-dc, the TRF6903 may be operated continuously in the learn mode and no training sequence is necessary before the transmission of a data string. However, the S&H capacitor voltage may be incorrect during power up or after long periods of inactivity (no data transmission); a learning sequence before each data transmission is recommended.

The comparator is a CMOS circuit that does not load the S&H capacitor. Leaving the transmission gate (LEARN/HOLD switch) open (in hold mode) during periods of inactivity, such as during standby, may be useful in maintaining the capacitor reference voltage. However, the reference voltage gradually discharges over time due to leakage current.

The time constant for charging the S&H capacitor is determined by its capacitance and an internal 51-kΩ resistor. A slow data rate requires a larger S&H capacitor (longer time constant). The value of the S&H capacitor, C<sub>sh</sub>, can be calculated with the following equation:

$$S \ \& \ H \ Cap = \frac{\text{Number of training Bits}}{5 \times 51k \times \text{Data Rate (Hz)}} ; \text{ Farad}$$

Where the data rate in Hz is the fundamental frequency (in Hz) of the base band waveform.

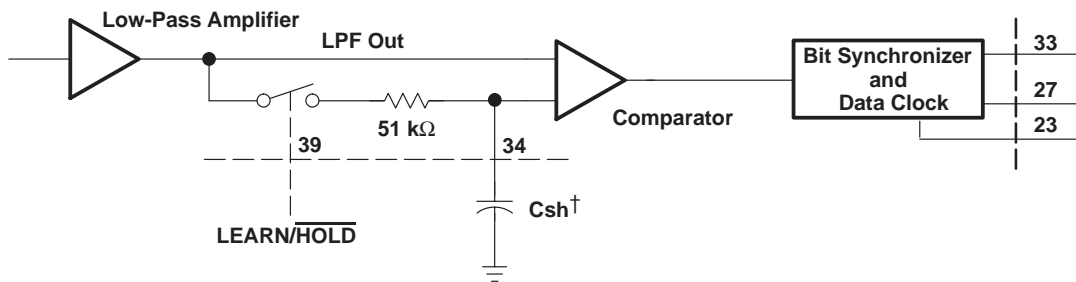

†External Sample-and-Hold Capacitor

**Figure 7. Data Slicer and Bit Synchronizer**

The received data and data clock output modes are determined by field RXM according to Table 3. When RXM, E<15:14> is set to 00, the raw data from the data slicer is output at terminal 33, RX\_DATA. No synchronization or data recovery is performed and the receiver can be used in an asynchronous mode. When RXM, E<15:14>, is set to 01, received data is first passed through a deglitching filter. These modes are useful for the reception of data whose baud rate is nonstandard.



**data slicer and bit synchronizer (continued)**

When RXM is set to enable recovered data, RXM E<15:14> = 10 or 11, the integrated bit synchronizer determines the preprogrammed data rate as determined by the crystal frequency and the values of D1, D2, and D3, and performs data recovery. Glitch-free, recovered data is then output at terminal 33, RX\_DATA, and the corresponding data clock is output at terminal 27, DCLK.

The preprogrammed bit rate can be calculated based on the following equation:

$$\text{Bit rate (kbps)} = \frac{\text{crystal frequency (kHz)}}{D1 \times D2 \times D3} = \frac{F_x}{D1 \times D2 \times D3} = f_c \text{ (kHz)}$$

where

- D1 = 1, 5, 6, or 8
- D2 = 1, 2, 4, 8, 16, 32, 64, or 128
- D3 = 15 or 16

**data clock**

When enabled, RXM = 10 or 11, the data clock circuitry provides as an output at terminal 27, DCLK, a data clock based on a programmable bit rate. The bit rate is programmable via variables D1, D2, and D3 and is always relative to the master clock (XTAL) frequency, F<sub>x</sub>. Table 2 shows common bit rates (kbps) vs selected crystal frequencies (MHz) and the respective settings of D1, D2, and D3.

**Table 2. Common Bit Rates, Corresponding Crystal Frequencies, and Values of D1, D2, and D3**

BIT RATE (kbps)	D1, D2, AND D3 MULTIPLIERS FOR COMMON CRYSTAL VALUES (CRYSTAL FREQUENCIES IN MHZ)					
	9.8304	12.288	14.7456	15.72864	16.384	19.6608
0.6	8x128x16					
0.9			8x128x16			
1		6x128x16			8x128x16	
1.024	5x128x15			8x128x15		
1.2	8x64x16	5x128x16	6x128x16			8x128x16
1.8			8x64x16			
2		6x64x16			8x64x16	
2.048	5x64x15			8x64x15		5x128x15
2.4	8x32x16	5x64x16	6x64x16			8x64x16
3.6			8x32x16			
4		6x32x16			8x32x16	
4.096	5x32x15			8x32x15		5x64x15
4.8	8x16x16	5x32x16	6x32x16			8x32x16
7.2			8x16x16			
8		6x16x16			8x16x16	
8.192	5x16x15			8x16x15		5x32x15
9.6	8x8x16	5x16x16	6x16x16			8x16x16
14.4			8x8x16			
16		6x8x16			8x8x16	
16.384	5x8x15			8x8x15		5x16x15
19.2	8x4x16	5x8x16	6x8x16			8x8x16
28.8			8x4x16			
32		6x4x16			8x4x16	
32.768	5x4x15			8x4x15		5x8x15
38.4	8x2x16	5x4x16	6x4 x16			8x4x16
57.6			8x2x16			
64		6x2x16			8x2x16	
65.536	5x2x15			8x2x15		5x4x15



# TRF6903 SINGLE-CHIP MULTIBAND RF TRANSCEIVER

SWRS022D – MARCH 2004 – REVISED JUNE 2005

## data clock (continued)

**Table 2. Common Bit Rates, Corresponding Crystal Frequencies, and Values of D1, D2, and D3 (continued)**

BIT RATE (kbps)	D1, D2, AND D3 MULTIPLIERS FOR COMMON CRYSTAL VALUES (CRYSTAL FREQUENCIES IN MHZ)					
	9.8304	12.288	14.7456	15.72864	16.384	19.6608
76.8	8x1x16	5x2x16	6x2x16			8x2x16
115.2			8x1x16			
128		6x1x16			8x1x16	

There are several receive modes, from raw slicer output to clock recovery and training sequence recognition. The receive logic is controlled by the RXM, TWO, and TCOUNT fields. The RXM, E<15:14>, field determines the receive mode as indicated in Table 3. These modes are described in more detail below.

**Table 3. Clock Recovery and Receive Data Modes Selected by RXM**

RXM	RECEIVE MODE	RX_DATA	DCLK	RX_FLAG
00	Raw data	Data direct from data slicer	Inactive; held low	Inactive; held low
01	Deglitch	Deglitched data	Active; clock synchronous to deglitched data	Inactive; held low
10	Clock recovery	Deglitched data; synchronous to bit-rate clock at DCLK	Active; synchronous bit-rate clock	Inactive; held low
11	Self train	Deglitched data; synchronous to bit-rate clock at DCLK	Active; synchronous bit-rate clock	Active; set high at first received bit that is not part of a predetermined training sequence

In *Raw Data* mode, the data slicer output is fed directly to the RX\_DATA terminal, and the DCLK and RX\_FLAG terminals are held low.

In *Deglitch* mode, the data slicer output is passed through the internal deglitch filter. This filter samples the slicer output at a rate  $f_{DG}$ , where

$$f_{DG} = \frac{F_x}{D1 \times D2}$$

The filter output is high if five or more of the last seven samples were high, and low if two or less of the last seven samples were high. Otherwise, the filter holds its previous value. The deglitched data is applied to the RX\_DATA terminal, and the over-sampled deglitch filter clock is passed on to the DCLK terminal. Data will appear on the RX\_DATA terminal a few gate delays after the rising edge of DCLK. The RX\_FLAG terminal is held low.

In *Clock Recovery* mode, the edges of the deglitched data are used to synchronize a bit-rate clock to the data. As long as the consecutive number of ones or zeros in the data stream,  $N_{CB}$ , meets the condition:

$$N_{CB} < \frac{250000}{\Delta_B} \quad \text{where } \Delta_B \text{ is the error between the transmit bit rate and the receiver bit-rate clock in ppm.}$$

The output data is synchronous with the bit-rate clock. The deglitched data is routed to the RX\_DATA terminal and the synchronized bit-rate clock appears at DCLK. The RX\_FLAG terminal is held low. The data transition is timed to coincide with the falling edge of DCLK, so that the external microcontroller using the TRF6903 can latch RX\_DATA on the rising edge of DCLK with plenty of setup and hold margin. If no data edges have been observed since the last reset, then DCLK is held low until an edge is seen.



### data clock (continued)

In *Self Train* mode, the TRF6903 receiver not only performs clock recovery, but also looks for the end of a training sequence. The TWO, E<12>, field determines the pattern of the training sequence. If TWO is low, the training sequence is assumed to be alternating ones and zeros; if TWO is high, the training sequence is assumed to be alternating pairs of ones and zeros. RX\_DATA and DCLK output are the same as in *Clock Recovery* mode. However, if a minimum number of training bits have been observed, then the RX\_FLAG terminal is asserted high for one clock period (after which it returns low) at the first bit that is not part of the training sequence. The timing of RX\_FLAG is a few gate delays after the rising edge of DCLK. The minimum number of training bits is four times the unsigned binary value of TCOUNT, E<11:7>, plus two if TWO = 0 or plus three if TWO = 1, according to the equation:

$$TB_{\min} = (4 \times TCOUNT) + TWO + 2$$

The clock recovery and training sequence recognition circuits are all designed to reset/clear internally with no user action required.

When active, DCLK is synchronized to the received data. The rising edge of the data clock is intended to be located at the middle of the received recovered data bit, thus enhancing the synchronization ability of the microcontroller and reducing the need for extensive signal processing in the microcontroller.

### main divider

The main divider is composed of a 5-bit A-counter and a 9-bit B-counter and a prescaler. The A-counter controls the divider ratio of the prescaler, which divides the VCO signal by either 33 or 32. The prescaler divides by 33 until the A-counter reaches its terminal count and then divides by 32 until the B-counter reaches terminal count, whereupon both counters reset and the cycle repeats. The total divide-by-N operation is related to the 32/33 prescaler by:

$$N_{\text{TOTAL}} = 33 \times A + 32 \times (B - A)$$

$$\text{where } 0 \leq A \leq 31 \text{ and } 31 \leq B \leq 511 \quad \text{or, } N_{\text{TOTAL}} = A + 32B$$

Thus, the N-divider has a range of  $992 \leq N_{\text{TOTAL}} \leq 16383$

### PLL

The phase-locked loop is the radio frequency synthesizer for the TRF6903. It is used to generate the transmit signal and as the local oscillator for the receive mixer. The signal ( $F_X$ ) from a reference crystal oscillator (XO) is divided by an integer factor R down to  $F_R$ . The minimum frequency resolution, and thus, the minimum channel spacing, is  $F_R$ .

$$F_R = F_X \div R \text{ where } 1 \leq R \leq 256$$

The phase-locked loop is an integer-N design. The voltage-controlled oscillator (VCO) signal is divided by an integer factor N to get a frequency at the phase detector input.

$$F_{PD} = F_{VCO} \div N$$

The phase detector compares the divided VCO signal to the divided crystal frequency and implements an error signal from two charge pumps. The error signal corrects the VCO output to the desired frequency.

As is in any integer-N PLLs, the VCO output has spurs at integer multiples of the reference frequency ( $nF_R$ ). In applications requiring contiguous frequency channels, the reference frequency is often chosen to be equal to the channel spacing, thus, channel spacing =  $F_R = F_X \div R$ . When the PLL is locked, the LOCK\_DETECT terminal is high.

# TRF6903 SINGLE-CHIP MULTIBAND RF TRANSCEIVER

SWRS022D – MARCH 2004 – REVISED JUNE 2005

## PLL (continued)

With the addition of an output divider for multiband operation, the actual output frequency,  $F_{out}$ , is given by:

$$F_{out} = \frac{F_{VCO}}{P} = \frac{F_X}{R} \times \frac{N}{P} = F_R \times \frac{N}{P} = \frac{A + 32B}{P} \times F_R$$

where  $F_R = F_{PD}$  under locked conditions. The actual minimum channel spacing is:

$$\frac{F_R}{P} = \frac{F_X \div R}{P}$$

where  $P = 1, 2, 3$  and is set by  $A<1:0>$ .

## oscillator circuit and reference divider

The reference divider reduces the frequency of the external crystal ( $F_X$ ) by an 8-bit programmable integer divisor,  $R$ , to an internal reference frequency ( $F_R$ ) used for the phase-locked loop. See Figure 8. The choice of internal reference frequency also has implications for lock time, maximum data rate, noise floor, and loop-filter design. The crystal frequency can be tuned using the  $F$  word to control internal trimming capacitors, which are placed in parallel with the crystal. These offset a small frequency error in the crystal. In an FSK application, an additional capacitor is placed in parallel (through terminal 31) with the external capacitor that is connected in series with the crystal, thus, changing the load capacitance as the transmit data switch (TX\_DATA, terminal 32) is toggled. The change in load capacitance pulls the crystal off-frequency by the total frequency deviation.

Hence, the 2-FSK frequency, set by the level of TX\_DATA and the external capacitor, can be represented as follows:

$$f_{out1} = \text{TX\_DATA Low (XTAL switch closed)} \text{ and } f_{out2} = \text{TX\_DATA High (XTAL switch open)}$$

Note that the frequencies  $f_{out1}$  and  $f_{out2}$  are centered about the frequency  $f_{center} = (f_{out1} + f_{out2})/2$ . When transmitting FSK,  $f_{center}$  is considered to be the effective carrier frequency and any receiver local oscillator (LO) should be set to the same  $f_{center}$  frequency  $\pm$  the receiver's IF frequency ( $f_{IF}$ ) for proper reception and demodulation.

For the case of high-side injection, the receiver LO would be set to  $f_{LO} = f_{center} + f_{IF}$ . Using high-side injection, the received data at terminal 33, RX\_DATA, would be inverted from the transmitted data applied at terminal 32, TX\_DATA. Conversely, for low-side injection, the receiver LO would be set to  $f_{LO} = f_{center} - f_{IF}$ . Using low-side injection, the received data would be the same as the transmitted data. The data polarity invert bit PI,  $A<4>$ , can be used to invert the data at terminal 33, RX\_DATA, when high-side injection is being used.

In addition, when the TRF6903 is placed in receive mode, it is recommended that the  $D<19>$  bit be kept high to keep the XTAL switch closed. In this manner, the actual LO frequency injected into the mixer is  $f_{out1} = f_{LO}$ . If  $D<19>$  is set low, the the receiver LO would be offset, resulting in poor receiver sensitivity.

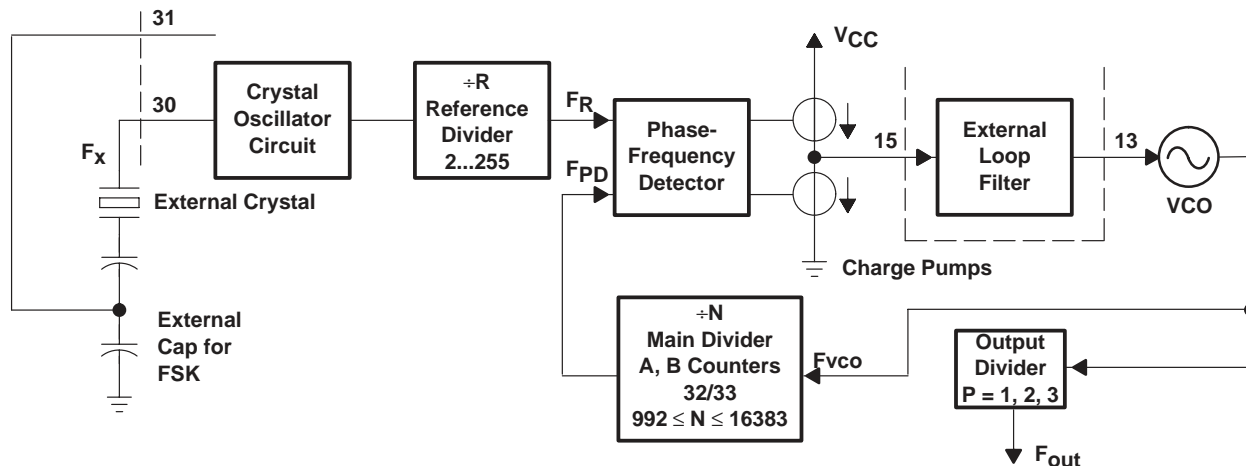

Figure 8. TRF6903 PLL and Output Divider

### phase detector and charge pumps

The phase detector is a phase-frequency design. The phase-frequency detector gain is given by:

$$K_P = I_{CP}/2\pi$$

where,  $I_{CP}$  is the peak charge pump current. The peak charge pump current is programmable with A<3:2> in three steps: 250  $\mu$ A, 500  $\mu$ A, and 1000  $\mu$ A.

### loop filter

The loop filter must be carefully chosen for proper operation of the TRF6903. The loop filter as shown in Figure 9 is typically a second- or third-order passive design and in FSK operation should have a bandwidth wide enough to allow the PLL to relock quickly as the external crystal frequency is pulled off-center during modulation. The loop filter should also be wider than the data modulation rate. These requirements should be balanced with making the loop narrow enough in consideration of the reference frequency. In OOK the VCO frequency is not changed during data modulation, so the filter bandwidth may be narrower than the modulation bandwidth. Filters can be calculated using standard formulas in reference literature. Some third-order filter examples are shown in Table 4.

$$F(s) = \frac{1 + sC2R2}{s(C1 + C2 + sC1C2R2)} \times \frac{1}{s + \frac{1}{C3R3}}$$

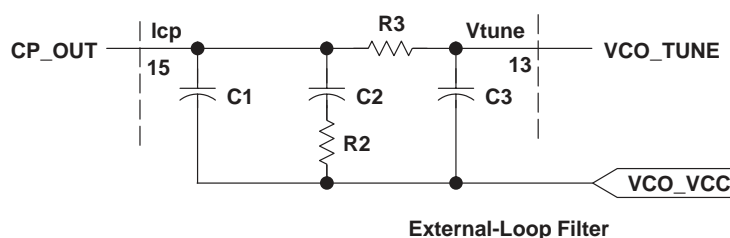

Figure 9. Third-Order Loop Filter and Transfer Function

Table 4. Loop Filter Component Values For Various Data Rates at a Reference Frequency of 409.6 kHz, 0.5-mA Charge Pump Current

Bit rate – kbps	Manchester coding	1.024	2.048	4.096	8.192	16.384	19.2	32.768	65.536
	NRZ coding	2.048	4.096	8.192	16.384	32.768	38.4	65.536	131.072
Data rate – kHz	Fundamental freq of BB	1.024	2.048	4.096	8.192	16.384	19.2	32.768	65.536
Loop filter component (selected to nearest standard value)	C1, nF	47	12	2.7	0.68	0.18	0.12	0.043	0.01
	C2, nF	1800	430	100	27	6.8	5.1	1.8	0.47
	C3, nF	27	6.8	1.5	0.39	0.1	0.075	0.027	0.0068
	R2, k $\Omega$	0.39	0.75	1.5	3	5.7	6.8	12	24
	R3, k $\Omega$	0.75	1.5	3	5.7	12	15	22	47
–3-dB bandwidth, kHz (approximate)		1.28	2.56	5.12	10.24	20.48	24	40.96	81.92

### VCO

The voltage-controlled oscillator (VCO) produces an RF output signal with a frequency that is dependent upon the dc-tuning voltage at terminal 13. The tank circuit is passive and has integrated varactor diodes and inductors. The open-loop VCO gain is approximately 100 MHz/V.

A <1:0> is used to set the output divider ratio for operation within the 315-MHz, 433-MHz, 868-MHz, or 915-MHz bands.

When the  $\overline{STDBY}$  terminal is high, the reference, PLL, VCO, and dividers are powered up. When  $\overline{STDBY}$  is low, these blocks are powered down.

# TRF6903 SINGLE-CHIP MULTIBAND RF TRANSCEIVER

SWRS022D – MARCH 2004 – REVISED JUNE 2005

## power amplifier

The power amplifier has three programmable attenuation states as determined by A<7:6> and B<7:6>: full power (0-dB attenuation), 10-dB attenuation, and 20-dB attenuation. This adjustment feature allows the user to fine-tune the device for optimal output power. The power amplifier can be enabled/disabled during transmit by bit B<3>, PARXED. During receive, the transmit power amplifier is powered down but the VCO and PLL are still operating. During ASK or OOK operation, the TX\_DATA signal turns the power amplifier on and off according to the transmit data incident at terminal 32.

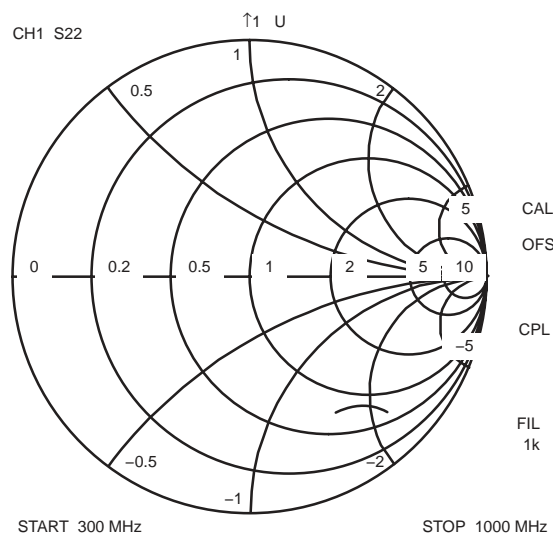

Figure 10. Typical PA Output Impedance (S22) at Device Terminal PA\_OUT

## brownout detector

The brownout detector provides an output voltage to indicate a low supply voltage. This may be used to signal the need to change transmit power to conserve battery life, or for system power down. The brownout detector threshold is set with the B word. Four different thresholds are available.

## serial control interface

The TRF6903 is controlled through a serial interface; there are five 24-bit control words (A, B, C, D, E) which set the device state. The A and B words are almost identical, and provide configuration settings for two modes, designated 0 and 1, which are commonly used to configure the transmit and receive states. The transmit and receive states can then be rapidly selected using MODE (terminal 21). The C word sets the reference dividers, the power amplifier bias, and contains various reset bits. The E word contains the bit-rate select, data clock control bits, and the power amplifier bias control registers. The D word is used to trim the external crystal frequency and tune the demodulator.

The register address is the composite of bits 23, 22, 1, and 0 of the 24 bits written to the serial interface. For some words, certain bits of the address are don't cares and are noted as XX. This flexible addressing scheme allows backward compatibility with the TRF6901, and because of this flexibility, the data length of each register varies from 15 bits to 22 bits.

Normal (write) operation of the serial interface is to clock in 24 bits through the CLOCK and DATA terminals. DATA values are clocked into the 24-bit serial interface shift register on the rising edge of CLOCK. The 24-bit value is decoded and written into the appropriate data register on the rising edge of STROBE.

## PRINCIPLES OF OPERATION

### register description

Word	Address																				Address		
	23	22	21	20	19	18	17	16	15	14	13	12	11	10	9	8	7	6	5	4		3	2
A	0	0	Main A-Divider Coefficient (Mode 0)					Main B-Divider Coefficient (Mode 0)							PA0	TX/RX0	PI	CP Acc.			BND		
B	0	1	Main A-Divider Coefficient (Mode 1)					Main B-Divider Coefficient (Mode 1)							PA1	TX/RX1	FSK/OOK	PARXED	Detector Threshold	Det. Enable			
C	1	0	Reference Divider Coefficient							Reserved							r	r	r	r	r	0	0
E	1	0	BRA	BRB	BRC	RXM	TXM	TWO	TCOUNT					0	0	r	r	r	0	1			
D	1	1	r	r	RXS	XTAL_Tune	PFD reset	Dem_Tune	OOKXS	r	r	r	r	r	r	r	r	r	r	r	r	r	0

NOTE: r = reserved. All reserved bits should be set low (0) during normal operation.

NOTE: All bits indicated as 1 should be set high (1) during normal operation.

NOTE: All bits indicated as 0 should be set low (0) during normal operation.

ADDRESS	LOCATION	NO. OF BITS	DESCRIPTION	DEFAULT VALUE
00xx	21:17	5	Main A divider coefficient (Mode 0)	00000
00xx	16:8	9	Main B divider coefficient (Mode 0)	001110000
00xx	7:6	2	Controls the PA attenuation (Mode 0)	10
00xx	5	1	Enables transmit/receive path (Mode 0)	0
00xx	4	1	Receive data polarity invert bit	0
00xx	3:2	2	Controls charge pump peak current	00
00xx	1:0	2	Output divider coefficient; band select	10
01xx	21:17	5	Main A divider coefficient (Mode 1)	00000
01xx	16:8	9	Main B divider coefficient (Mode 1)	001110000
01xx	7:6	2	Controls the PA attenuation (Mode 1)	10
01xx	5	1	Enables transmit/receive path (Mode 1)	0
01xx	4	1	Controls modulation scheme (FSK or OOK)	0
01xx	3	1	Enables or disables the power amplifier while in transmit mode or the receive chain while in receive mode	0
01xx	2:1	2	Sets threshold for the brownout detector	00
01xx	0	1	Enables brownout detector	0
1000	21:14	8	Reference divider coefficient	01000000
1001	21:20	2	Bit-rate divider D1	11
1001	19:17	3	Bit-rate divider D2	010
1001	16	1	Bit-rate divider D3	0
1001	15:14	2	Receive mode select	00
1001	13	1	Transmit capture mode select	0
1001	12	1	RX training sequence pattern select	0
1001	11:7	5	Determines the minimum number of training bits	00100
11x0	19	1	Controls the position of the XTAL switch during FSK reception	0
11x0	18:16	3	Tunes the XTAL frequency by using an internal capacitor bank	000
11x0	15	1	PFD reset	1
11x0	14:12	3	Tunes the resonant frequency of the external demodulation tank circuit	000
11x0	11	1	Controls the position of the XTAL switch during OOK operation	0

NOTE: x = don't care



# TRF6903 SINGLE-CHIP MULTIBAND RF TRANSCEIVER

SWRS022D – MARCH 2004 – REVISED JUNE 2005

## PRINCIPLES OF OPERATION

At power on/startup, all of the TRF6903 register contents are as per the default values.

### Address 00XX (A-Word):

Word A is a 22-bit data register comprising seven fields. The main A-divider coefficient (mode 0), A<21:17>, is the 5-bit divider ratio of the A counter when the MODE terminal is low. The main B-divider coefficient (mode 0), A<16:8>, is the 9-bit value of the B counter when the MODE terminal is low. A <21:17> and A <16:8> are unsigned binary values. PA0, A<7:6>, is the 2-bit PA attenuation setting when the MODE terminal is low. TX/RX0, A<5>, is the TX/RX switch when the MODE terminal is low. PI, A<4>, is the data polarity invert bit. When high, this bit causes the data slicer output to be inverted. CP Acc., A<3:2>, sets the charge pump current. BND, A<1:0>, sets the output divider, which in turn determines the band of operation.

Terminal 21 (MODE) selects bits A<21:5> if low, or B<21:5> if high.

Main divider A<21:17>: 5-bit value for divider ratio of the A counter

Main divider A<16:8>: 9-bit value for divider ratio of the B counter

PA attenuation A<7:6>: 2 bits for setting the PA attenuation

A<7:6>	PA ATTENUATION
00	0 dB
01	10 dB
10	20 dB
11	Not defined

A<5>: 1-bit TX/RX mode select

A<5>	TX/RX MODE
0	RX mode
1	TX mode

A<4>: 1-bit data polarity invert bit

A<4>	RX DATA POLARITY
0	Noninverted
1	Inverted

A<3:2>: 2 bits for setting the charge pump current

A<3:2>	CP CURRENT
00	0.5 mA
01	1 mA
10	0.25 mA
11	Not defined



## PRINCIPLES OF OPERATION

A<1:0>: 2-bit value to set the output divider and thus select the band of operation.

A<1:0>	OUTPUT DIVIDER RATIO, P	BAND OF OPERATION
00	3	315 MHz
01	2	433 MHz
10	1	868 MHz or 915 MHz
11	1	868 MHz or 915 MHz

### Address 01XX (B-Word):

Word B is a 22-bit data register comprising eight fields. The main A-divider coefficient (mode 1), B<21:17>, is the 5-bit divider ratio of the A counter when the MODE terminal is high. The main B-divider coefficient (mode 1), B<16:8>, is the 9-bit value of the B counter when the MODE terminal is high. B<21:17> and B<16:8> are unsigned binary values. PA1, B<7:6>, is the 2-bit PA attenuation setting when the MODE terminal is high. TX/RX1, B<5>, is the TX/RX switch when the MODE terminal is high. FSK/OOK, B<4>, sets the modulation scheme for both TX and RX. Bit B<3> enables/disables the power amplifier while in transmit mode and enables/disables the receive chain while in receive mode. The detector threshold, B<2:1>, is the 2-bit setting for the threshold voltage of the brownout detector. Det. Enable, B<0>, is the brownout detector enable flag.

Terminal 21 (MODE) selects bits A<21:5> if low, or B<21:5> if high.

Main divider B<21:17>: 5-bit value for divider ratio of the A-counter  
Main divider B<16:8>: 9-bit value for divider ratio of the B-counter

PA attenuation B<7:6>: 2 bits for setting the PA attenuation

B<7:6>	PA ATTENUATION
00	0 dB
01	10 dB
10	20 dB
11	Not defined

B<5>: 1-bit TX/RX mode select

B<5>	TX/RX MODE
0	RX mode
1	TX mode

B<4> 1-bit modulation select

B<4>	TX/RX MODULATION
0	OOK
1	FSK

NOTE: During OOK reception, the OOK switch is closed. During FSK reception, the OOK switch is open.

# TRF6903 SINGLE-CHIP MULTIBAND RF TRANSCEIVER

SWRS022D – MARCH 2004 – REVISED JUNE 2005

---

## PRINCIPLES OF OPERATION

B<3>: 1-bit PA or receive chain enable/disable

B<3>	PA OR RECEIVE CHAIN ENABLE/DISABLE
0	Disabled
1	Enabled

B<2:1>: 2-bit value to set the threshold voltage for the brownout detector

B<2:1>	THRESHOLD VOLTAGE
00	2.2 V
01	2.4 V
10	2.6 V
11	2.8 V

B<0>: 1 bit to enable brownout detector

B<0>	BROWNOUT DETECTOR
0	Off
1	On

### Address 1000 (C-Word):

Word C is a 20-bit data register comprising four fields. The reference divider coefficient, C<21:14>, is the 8-bit divider ratio of the reference divider. The allowable reference divider range is 2 (C <21:14> = 00000010) through 255 (C <21:14> = 11111111).

Bits C<13> through C<2> are reserved and should be set to 0.

### Address 1001 (E-Word):

Word E is a 20-bit data register comprising eight fields. The bit rate or bit frequency, used by the clock recovery receive modes and the transmit synchronous mode is controlled by the BRA, E<21:20>, BRB, E<19:17>, and BRC, E<16>, fields. These three fields control a sequence of dividers, D1 through D3, that divide the reference (crystal) frequency,  $F_X$ .

## PRINCIPLES OF OPERATION

E<21:20>: 2 bits to set D1 divider setting

E<21:20>	D1
00	1
01	5
10	6
11	8

E<19:17>: 3 bits to set D2 divider setting

E<19:17>	D2
000	1
001	2
010	4
011	8
100	16
101	32
110	64
111	128

E<16>: 1 bit to set D3 divider setting

E<16>	D3
0	16
1	15

RXM, E<15:14> controls the signals that appear at the RX\_DATA and DCLK terminals. The definition of RXM is contained in Table 3.

TXM, E<13>, sets the transmit capture mode. If TXM is low, the TX\_DATA terminal controls the transmit function asynchronously. If TXM is high, the bit-rate clock is output at DCLK and the transmit data at the TX\_DATA terminal is latched on the rising edge of DCLK, where DCLK is the bit-rate clock.

TWO, E<12>, sets the receive training sequence pattern. If TWO is high, the expected training sequence is assumed to be alternating pairs of ones and zeroes. If TWO is low, the expected training sequence is assumed to be alternating ones and zeroes.

TCOUNT, E<11:7>, determines the minimum number of training bits. The minimum number of training bits is four times the unsigned binary value of TCOUNT, plus two if TWO = 0 or plus three if TWO = 1.

Bits E<6> through E<2> are reserved and should be set to 0.

### Address 11X0 (D-Word):

Word D is a 21-bit data register comprising three fields. XTAL\_Tune, D<18:16>, is used to fine tune the crystal frequency by using an internal capacitor bank. PFD reset, D<15>, selects the source of the PFD reset signal. Dem\_Tune, D<14:12>, is a 3-bit value used to tune the demodulator time constant. Bit D<11> controls the position of the XTAL switch during OOK operation.

D<19>: 1-bit value to control the position of the XTAL switch during FSK reception, when B<4>=1 and either A<5> or B<5> = 0. It is recommended to set this bit to 1 (XTAL switch closed). If D<19> is set to 0 (XTAL switch open), the LO frequency injected into the mixer is  $f_{outs} = f_{LO} + \text{designed peak-peak deviation}$ . This results in the down-converted IF signal shifting higher (high-side injection) or lower (low-side injection) from the IF center frequency (10.7 MHz) by an amount equal to the designed peak-peak frequency deviation.

# TRF6903 SINGLE-CHIP MULTIBAND RF TRANSCEIVER

SWRS022D – MARCH 2004 – REVISED JUNE 2005

## PRINCIPLES OF OPERATION

D<19>	XTAL SWITCH DURING FSK RECEPTION	TERMINAL 31
0	Unconnected (open)	High-Z
1	Connected (closed)	Shorted to ground internally

D<18:16>: 3-bit value to fine-tune the XTAL frequency by using an internal capacitor bank.

D<18:16>	TYPICAL LOAD CAPACITANCE
000	13.23 pF
001	22.57 pF
010	17.9 pF
011	27.24 pF
100	15.56 pF
101	24.9 pF
110	20.23 pF
111	29.57 pF

D<15>: 1-bit value to select the reset signal for the PFD

D<15>	RESET SIGNAL
0	Derived from XTAL
1	Derived from prescaler

NOTE: The default setting for D<15> is 1.

D<14:12>: 3-bit value to tune the resonant frequency of the external demodulator tank circuit. It can be used to optimize the receiver performance. The recommended default setting is 110.

D<11>: 1-bit value to control position of the XTAL switch during OOK operation, when B<4> = 0.

D<11>	XTAL SWITCH DURING OOK OPERATION	TERMINAL 31
0	Unconnected (open)	High-Z
1	Connected (closed)	Shorted to ground internally

It is recommended that D<19> and D<11> be set to 0 during FSK reception and OOK operation.

Bits D<21>, D<20>, and D<10> through D<1> are reserved and should be set to 0.

## operating modes

Controlled with terminal 26,  $\overline{\text{STDBY}}$

$\overline{\text{STDBY}}$	OPERATING MODE
0	Power down of all blocks—programming mode
1	Operational mode and programming mode

Controlled with terminal 21, MODE

MODE	OPERATING MODE
0	Enable A-word
1	Enable B-word



## PRINCIPLES OF OPERATION

Controlled with terminal 39,  $\overline{\text{LEARN/HOLD}}$

$\overline{\text{LEARN/HOLD}}$	OPERATING MODE
0	Selects data slicer decision level to HOLD
1	Selects data slicer decision level to LEARN

The transmit/receive mode is controlled by the TX/RX0, A<5>, TX/RX1, B<5>, and PARXED, B<3>, fields and the MODE and  $\overline{\text{STDBY}}$  terminals.

A<5>	B<5>	B<3>	MODE	$\overline{\text{STDBY}}$	OPERATING MODE
X	X	X	X	0	Off, programming mode; SPI enabled
0	X	0	0	1	Receive mode 0, RX chain disabled. Reference, PLL, VCO and dividers enabled
0	X	1	0	1	Receive mode 0, RX chain enabled. Reference, PLL, VCO and dividers enabled
1	X	0	0	1	Transmit mode 0, PA disabled. Reference, PLL, VCO and dividers enabled
1	X	1	0	1	Transmit mode 0, PA enabled. Reference, PLL, VCO and dividers enabled
X	0	0	1	1	Receive mode 1, RX chain disabled. Reference, PLL, VCO and dividers enabled
X	0	1	1	1	Receive mode 1, RX chain enabled. Reference, PLL, VCO and dividers enabled
X	1	0	1	1	Transmit mode 1, PA disabled. Reference, PLL, VCO and dividers enabled
X	1	1	1	1	Transmit mode 1, PA enabled. Reference, PLL, VCO and dividers enabled

# TRF6903 SINGLE-CHIP MULTIBAND RF TRANSCEIVER

SWRS022D – MARCH 2004 – REVISED JUNE 2005

## APPLICATION INFORMATION

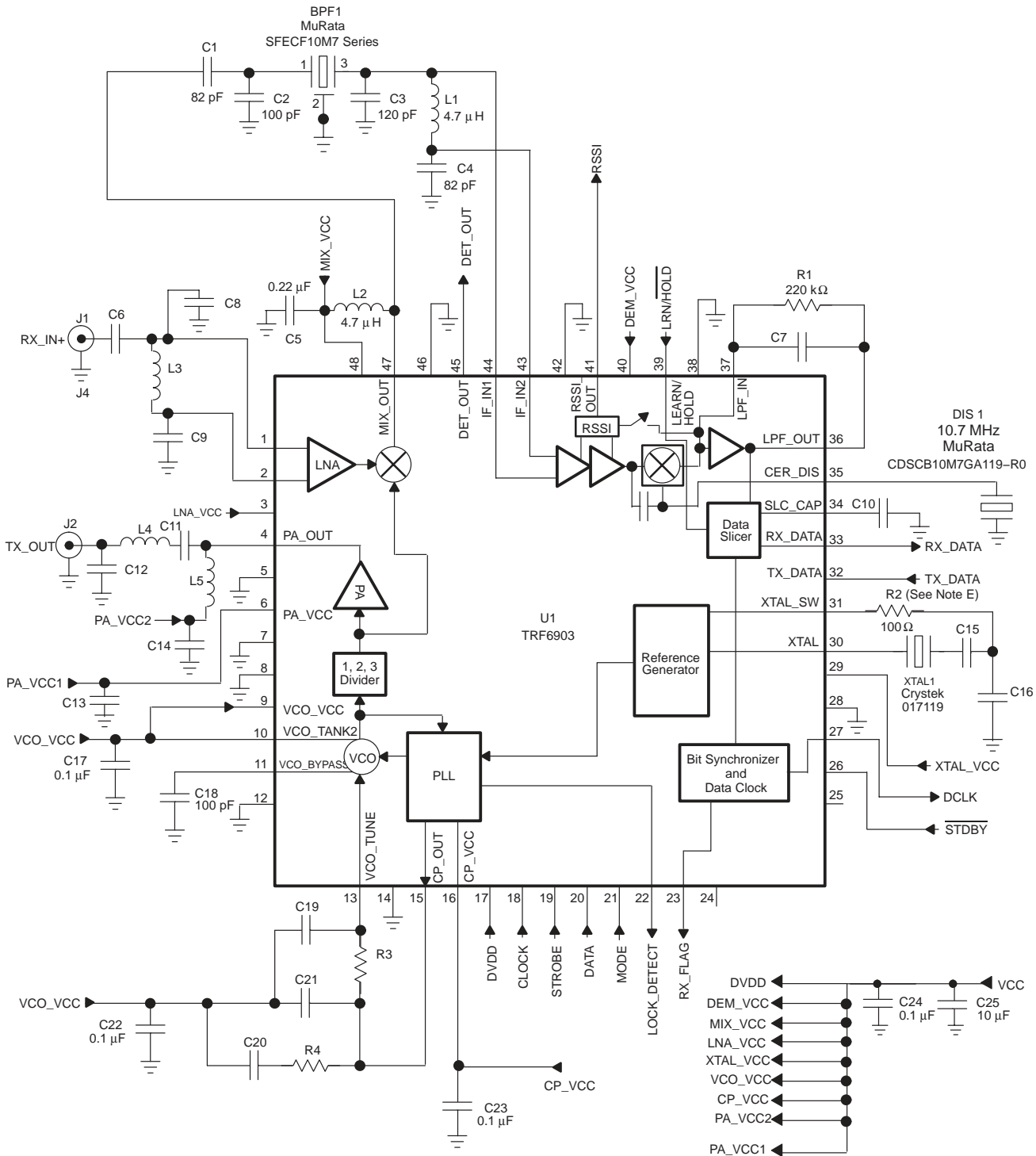

NOTE: See Table 5 for component selection for band of operation.

Figure 11. Typical TRF6903 FSK Application Schematic

**APPLICATION INFORMATION**

**Table 5. Component Selection for Band of Operation, FSK**

	315 MHz		433 MHz		868 MHz		915 MHz	
	Component	Value	Component	Value	Component	Value	Component	Value
Rx LNA Matching Network	C8	15 pF	C8	8.2 pF	C8	2.7 pF	C8	1.5 pF
	C6	330 pF	C6	180 pF	C6	39 pF	C6	33 pF
	C9	15 pF	C9	8.2 pF	C9	2.7 pF	C9	1.8 pF
	L3	27 nH	L3	22 nH	L3	15 nH	L3	12 nH
Tx PA Matching Network	C11	390 pF	C11	270 pF	C11	43 pF	C11	43 pF
	C14	390 pF	C14	270 pF	C14	39 pF	C14	33 pF
	L5	560 nH	L5	470 nH	L5	330 nH	L5	270 nH
	L4	75 nH	L4	39 nH	L4	15 nH	L4	15 nH
	C12	7.5 pF	C12	6.8 pF	C12	3.9 pF	C12	2.7 pF
	C13	390 pF	C13	270 pF	C13	39 pF	C13	33 pF
PLL Loop Filter	C19	75 pF	C19	75 pF	C19	75 pF	C19	75 pF
	C21	120 pF	C21	120 pF	C21	120 pF	C21	120 pF
	C20	5600 pF	C20	5600 pF	C20	5600 pF	C20	5600 pF
	R3	15 k $\Omega$	R3	15 k $\Omega$	R3	15 k $\Omega$	R3	15 k $\Omega$
	R4	7.5 k $\Omega$	R4	7.5 k $\Omega$	R4	7.5 k $\Omega$	R4	7.5 k $\Omega$
Post Detection Low-Pass Filter	C7	18 pF	C7	18 pF	C7	18 pF	C7	18 pF
Sample and Hold Capacitor	C10	3300 pF	C10	3300 pF	C10	3300 pF	C10	3300 pF
XTAL Switch Capacitor	C15	27 pF	C15	27 pF	C15	27 pF	C15	27 pF
	C16	5.6 pF	C16	9.1 pF	C16	20 pF	C16	22 pF

- NOTES: A. Loop filter components selected for 19.2-kbps Manchester or 38.4-kbps NRZ for each band.  $I_{CP} = 0.5$  mA, Reference Frequency = 409.6 kHz
- B. Post detection low-pass filter selected for 19.2-kbps Manchester or 38.4-kbps NRZ.
- C. Sample and hold capacitor selected for 7-bit training sequence and TWO = 0 (E<12>:0)
- D. XTAL switch capacitors selected for the frequency deviation of  $\pm 50$  kHz.
- E. R2 = 100  $\Omega$  is optional for operation in the 868-MHz and 915-MHz bands.

# TRF6903 SINGLE-CHIP MULTIBAND RF TRANSCEIVER

SWRS022D – MARCH 2004 – REVISED JUNE 2005

## APPLICATION INFORMATION

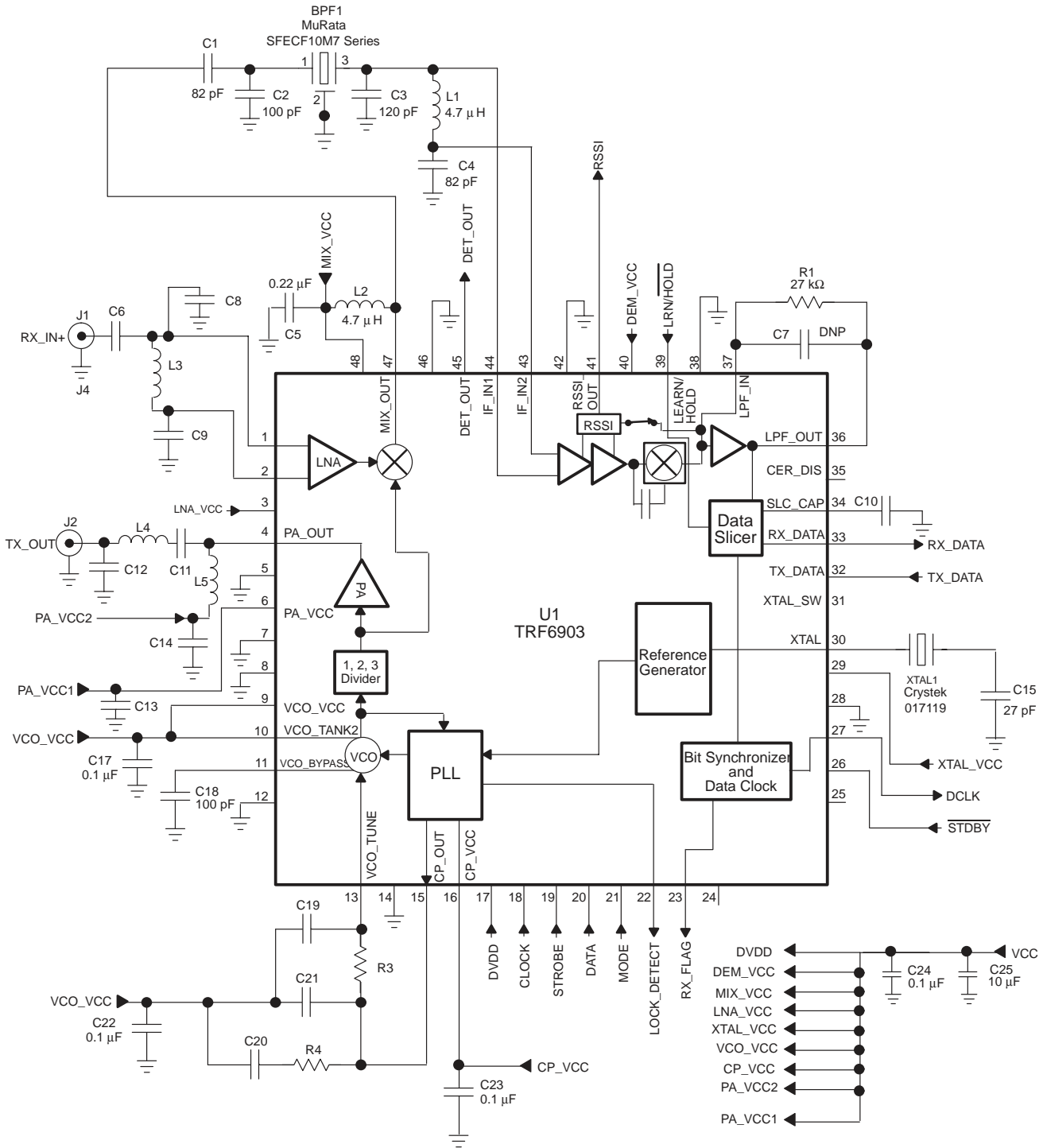

NOTE: See Table 6 for component selection for band of operation.

**Figure 12. Typical TRF6903 OOK Application Schematic With Ceramic IF Filter**



**APPLICATION INFORMATION**

**Table 6. Component Selection for Band of Operation, OOK**

	315 MHz		433 MHz		868 MHz		915 MHz	
	Component	Value	Component	Value	Component	Value	Component	Value
Rx LNA Matching Network	C8	15 pF	C8	8.2 pF	C8	2.7 pF	C8	1.5 pF
	C6	330 pF	C6	180 pF	C6	39 pF	C6	33 pF
	C9	15 pF	C9	8.2 pF	C9	2.7 pF	C9	1.8 pF
	L3	27 nH	L3	22 nH	L3	15 nH	L3	12 nH
Tx PA Matching Network	C11	390 pF	C11	270 pF	C11	43 pF	C11	43 pF
	C14	390 pF	C14	270 pF	C14	39 pF	C14	33 pF
	L5	560 nH	L5	470 nH	L5	330 nH	L5	270 nH
	L4	75 nH	L4	39 nH	L4	15 nH	L4	15 nH
	C12	7.5 pF	C12	6.8 pF	C12	3.9 pF	C12	2.7 pF
	C13	390 pF	C13	270 pF	C13	39 pF	C13	33 pF
PLL Loop Filter	C19	75 pF	C19	75 pF	C19	75 pF	C19	75 pF
	C21	120 pF	C21	120 pF	C21	120 pF	C21	120 pF
	C20	5600 pF	C20	5600 pF	C20	5600 pF	C20	5600 pF
	R3	15 k $\Omega$	R3	15 k $\Omega$	R3	15 k $\Omega$	R3	15 k $\Omega$
	R4	7.5 k $\Omega$	R4	7.5 k $\Omega$	R4	7.5 k $\Omega$	R4	7.5 k $\Omega$
Sample and Hold Capacitor	C10	3300 pF	C10	3300 pF	C10	3300 pF	C10	3300 pF

- NOTES: A. Loop filter components selected for 19.2-kbps Manchester or 38.4-kbps NRZ for each band.  $I_{CP} = 0.5$  mA, Reference Frequency = 409.6 kHz  
 B. Sample and hold capacitor selected for 7-bit training sequence and TWO = 0 (E<12>:0)

# TRF6903 SINGLE-CHIP MULTIBAND RF TRANSCEIVER

SWRS022D – MARCH 2004 – REVISED JUNE 2005

---

## Revision History

DATE	REV	PAGE	SECTION	DESCRIPTION
6/2/05	D	1	—	Added application drawing to front page.
—	C	—	—	Information not available
—	B	—	—	Information not available
—	A	—	—	Information not available
—	*	—	—	Information not available

NOTE: Page numbers for previous revisions may differ from page numbers in the current version.

**PACKAGING INFORMATION**

Orderable Device	Status (1)	Package Type	Package Drawing	Pins	Package Qty	Eco Plan (2)	Lead finish/ Ball material (6)	MSL Peak Temp (3)	Op Temp (°C)	Device Marking (4/5)	Samples
TRF6903PT	NRND	LQFP	PT	48	250	RoHS & Green	NIPDAU	Level-1-260C-UNLIM		TRF6903	
TRF6903PTR	NRND	LQFP	PT	48	1000	RoHS & Green	NIPDAU	Level-1-260C-UNLIM		TRF6903	

(1) The marketing status values are defined as follows:

**ACTIVE:** Product device recommended for new designs.

**LIFEBUY:** TI has announced that the device will be discontinued, and a lifetime-buy period is in effect.

**NRND:** Not recommended for new designs. Device is in production to support existing customers, but TI does not recommend using this part in a new design.

**PREVIEW:** Device has been announced but is not in production. Samples may or may not be available.

**OBSELETE:** TI has discontinued the production of the device.

(2) **RoHS:** TI defines "RoHS" to mean semiconductor products that are compliant with the current EU RoHS requirements for all 10 RoHS substances, including the requirement that RoHS substance do not exceed 0.1% by weight in homogeneous materials. Where designed to be soldered at high temperatures, "RoHS" products are suitable for use in specified lead-free processes. TI may reference these types of products as "Pb-Free".

**RoHS Exempt:** TI defines "RoHS Exempt" to mean products that contain lead but are compliant with EU RoHS pursuant to a specific EU RoHS exemption.

**Green:** TI defines "Green" to mean the content of Chlorine (Cl) and Bromine (Br) based flame retardants meet JS709B low halogen requirements of <=1000ppm threshold. Antimony trioxide based flame retardants must also meet the <=1000ppm threshold requirement.

(3) MSL, Peak Temp. - The Moisture Sensitivity Level rating according to the JEDEC industry standard classifications, and peak solder temperature.

(4) There may be additional marking, which relates to the logo, the lot trace code information, or the environmental category on the device.

(5) Multiple Device Markings will be inside parentheses. Only one Device Marking contained in parentheses and separated by a "~" will appear on a device. If a line is indented then it is a continuation of the previous line and the two combined represent the entire Device Marking for that device.

(6) Lead finish/Ball material - Orderable Devices may have multiple material finish options. Finish options are separated by a vertical ruled line. Lead finish/Ball material values may wrap to two lines if the finish value exceeds the maximum column width.

**Important Information and Disclaimer:**The information provided on this page represents TI's knowledge and belief as of the date that it is provided. TI bases its knowledge and belief on information provided by third parties, and makes no representation or warranty as to the accuracy of such information. Efforts are underway to better integrate information from third parties. TI has taken and continues to take reasonable steps to provide representative and accurate information but may not have conducted destructive testing or chemical analysis on incoming materials and chemicals. TI and TI suppliers consider certain information to be proprietary, and thus CAS numbers and other limited information may not be available for release.

In no event shall TI's liability arising out of such information exceed the total purchase price of the TI part(s) at issue in this document sold by TI to Customer on an annual basis.

**TAPE AND REEL INFORMATION**

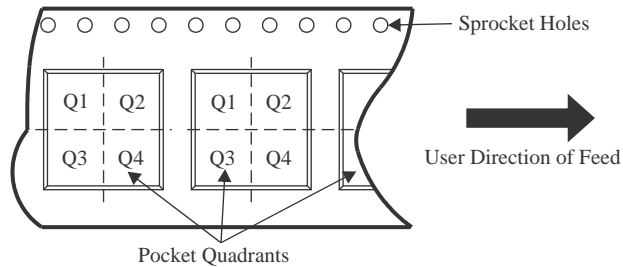
**QUADRANT ASSIGNMENTS FOR PIN 1 ORIENTATION IN TAPE**

\*All dimensions are nominal

Device	Package Type	Package Drawing	Pins	SPQ	Reel Diameter (mm)	Reel Width W1 (mm)	A0 (mm)	B0 (mm)	K0 (mm)	P1 (mm)	W (mm)	Pin1 Quadrant
TRF6903PTR	LQFP	PT	48	1000	330.0	16.4	9.6	9.6	1.9	12.0	16.0	Q2

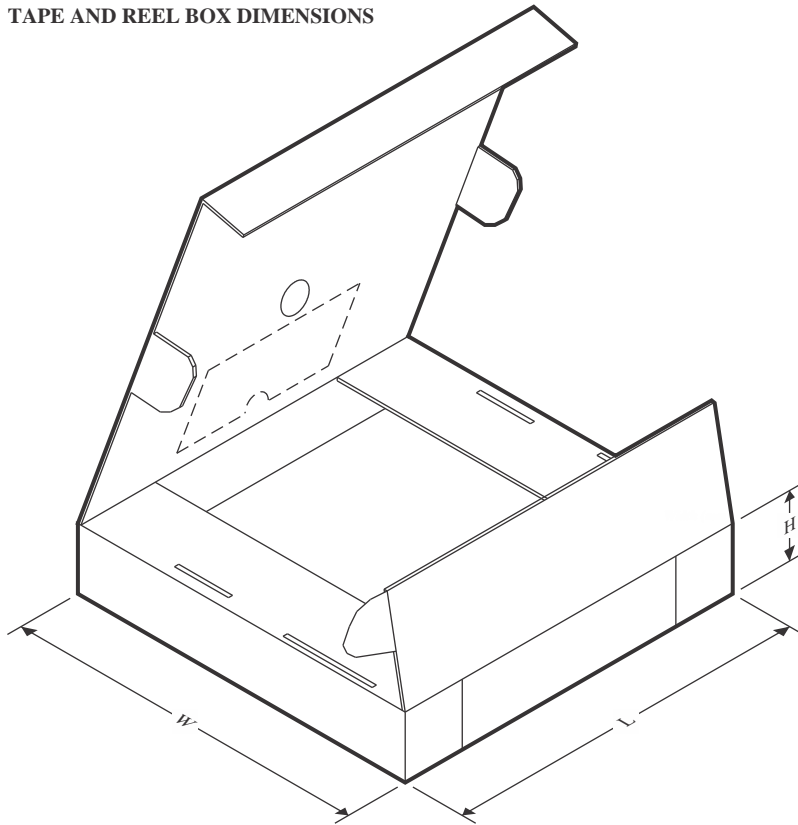
**TAPE AND REEL BOX DIMENSIONS**

\*All dimensions are nominal

Device	Package Type	Package Drawing	Pins	SPQ	Length (mm)	Width (mm)	Height (mm)
TRF6903PTR	LQFP	PT	48	1000	350.0	350.0	43.0

**TRAY**

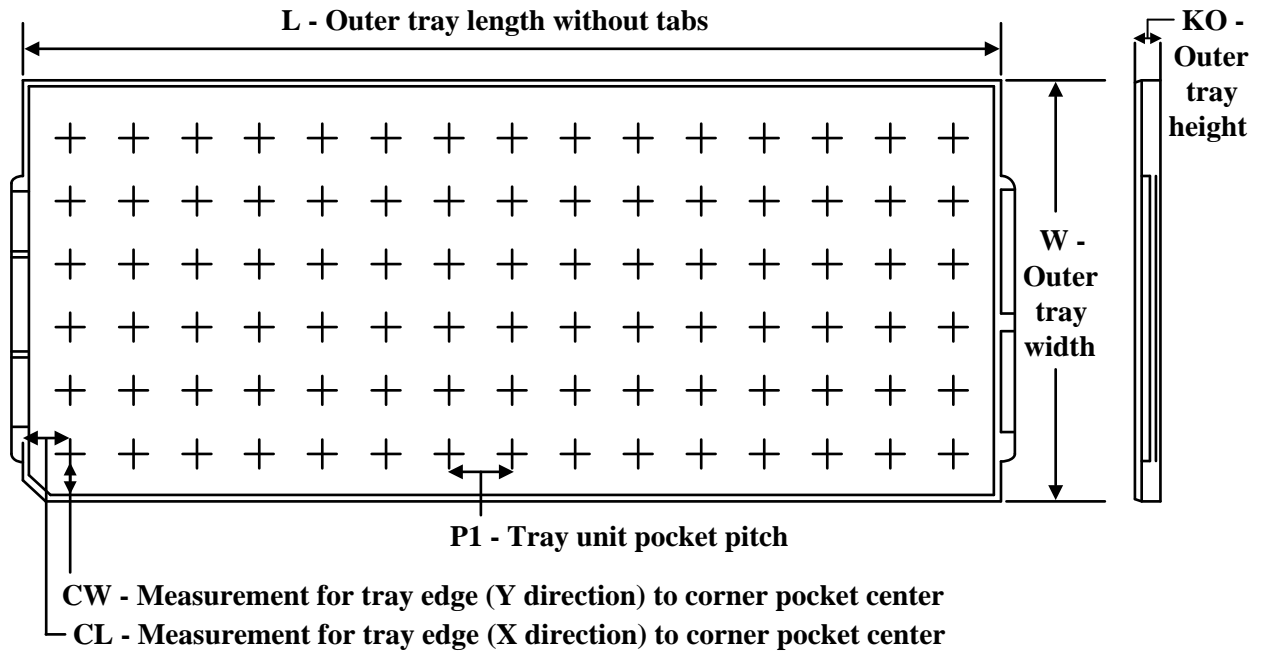

Chamfer on Tray corner indicates Pin 1 orientation of packed units.

\*All dimensions are nominal

Device	Package Name	Package Type	Pins	SPQ	Unit array matrix	Max temperature (°C)	L (mm)	W (mm)	K0 (µm)	P1 (mm)	CL (mm)	CW (mm)
TRF6903PT	PT	LQFP	48	250	10 x 25	150	315	135.9	7620	12.2	11.1	11.25

PT0048A



# PACKAGE OUTLINE

LQFP - 1.6 mm max height

LOW PROFILE QUAD FLATPACK

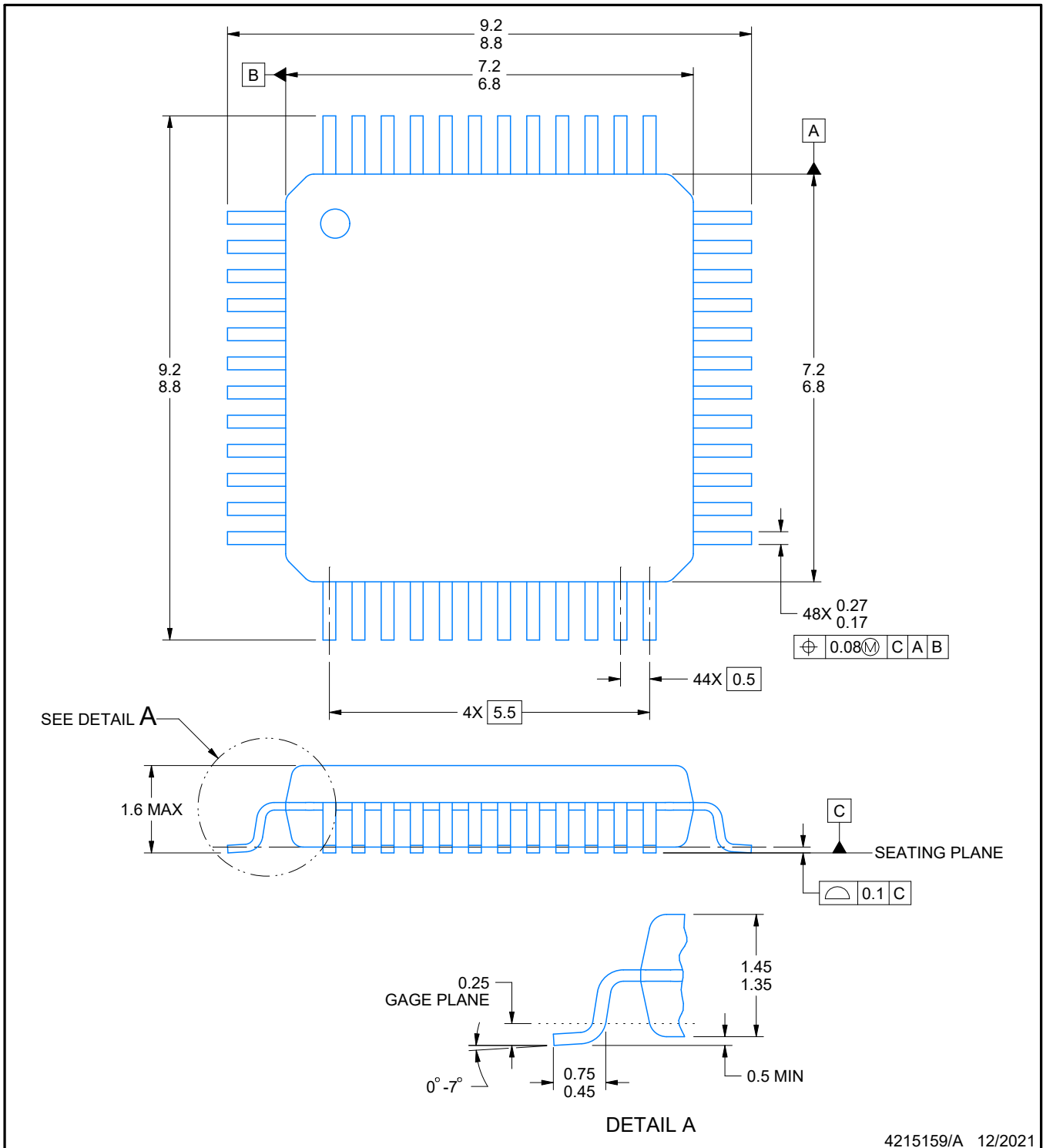

NOTES:

1. All linear dimensions are in millimeters. Any dimensions in parenthesis are for reference only. Dimensioning and tolerancing per ASME Y14.5M.
2. This drawing is subject to change without notice.
3. Reference JEDEC registration MS-026.
4. This may also be a thermally enhanced plastic package with leads connected to the die pads.

# EXAMPLE BOARD LAYOUT

PT0048A

LQFP - 1.6 mm max height

LOW PROFILE QUAD FLATPACK

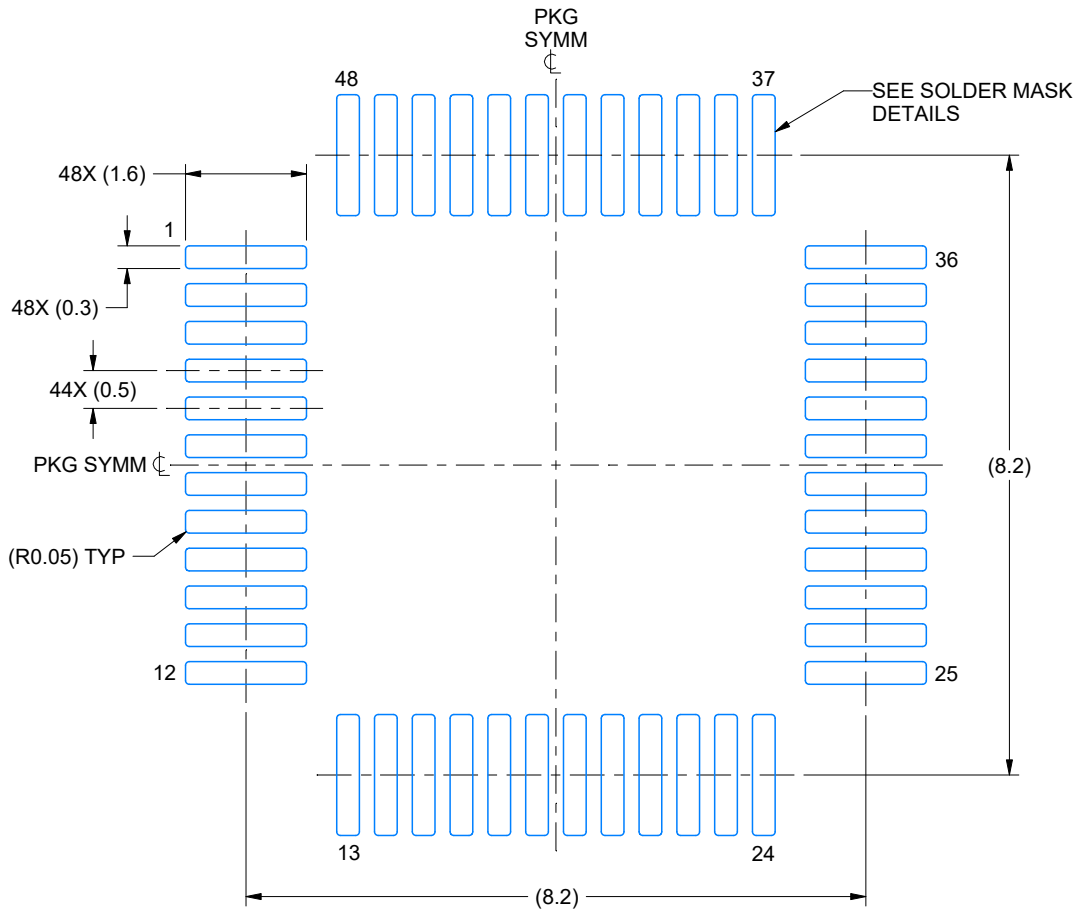

LAND PATTERN EXAMPLE  
EXPOSED METAL SHOWN  
SCALE 10.000

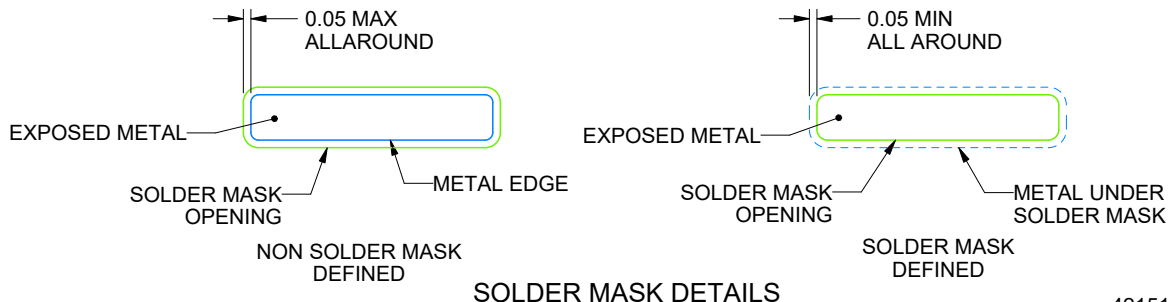

SOLDER MASK DETAILS

4215159/A 12/2021

NOTES: (continued)

- 5. Publication IPC-7351 may have alternate designs.
- 6. Solder mask tolerances between and around signal pads can vary based on board fabrication site.



# EXAMPLE STENCIL DESIGN

PT0048A

LQFP - 1.6 mm max height

LOW PROFILE QUAD FLATPACK

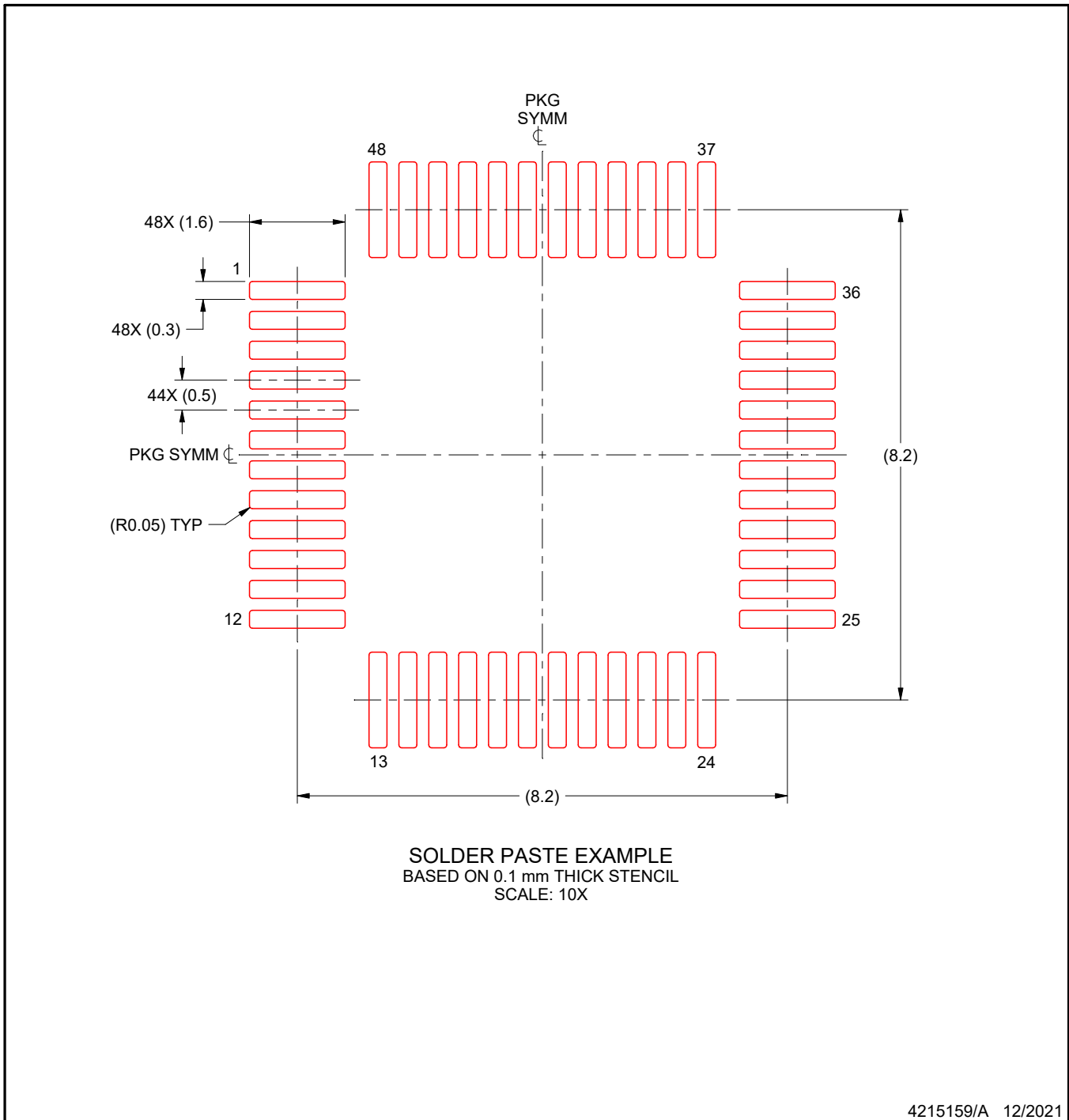

NOTES: (continued)

7. Laser cutting apertures with trapezoidal walls and rounded corners may offer better paste release. IPC-7525 may have alternate design recommendations.
8. Board assembly site may have different recommendations for stencil design.

## IMPORTANT NOTICE AND DISCLAIMER

TI PROVIDES TECHNICAL AND RELIABILITY DATA (INCLUDING DATA SHEETS), DESIGN RESOURCES (INCLUDING REFERENCE DESIGNS), APPLICATION OR OTHER DESIGN ADVICE, WEB TOOLS, SAFETY INFORMATION, AND OTHER RESOURCES "AS IS" AND WITH ALL FAULTS, AND DISCLAIMS ALL WARRANTIES, EXPRESS AND IMPLIED, INCLUDING WITHOUT LIMITATION ANY IMPLIED WARRANTIES OF MERCHANTABILITY, FITNESS FOR A PARTICULAR PURPOSE OR NON-INFRINGEMENT OF THIRD PARTY INTELLECTUAL PROPERTY RIGHTS.

These resources are intended for skilled developers designing with TI products. You are solely responsible for (1) selecting the appropriate TI products for your application, (2) designing, validating and testing your application, and (3) ensuring your application meets applicable standards, and any other safety, security, regulatory or other requirements.

These resources are subject to change without notice. TI grants you permission to use these resources only for development of an application that uses the TI products described in the resource. Other reproduction and display of these resources is prohibited. No license is granted to any other TI intellectual property right or to any third party intellectual property right. TI disclaims responsibility for, and you will fully indemnify TI and its representatives against, any claims, damages, costs, losses, and liabilities arising out of your use of these resources.

TI's products are provided subject to [TI's Terms of Sale](#) or other applicable terms available either on [ti.com](https://www.ti.com) or provided in conjunction with such TI products. TI's provision of these resources does not expand or otherwise alter TI's applicable warranties or warranty disclaimers for TI products.

TI objects to and rejects any additional or different terms you may have proposed.

Mailing Address: Texas Instruments, Post Office Box 655303, Dallas, Texas 75265  
Copyright © 2023, Texas Instruments Incorporated