



- [Products](#)
- [Design Resources](#)
- [Technical Info](#)
- [Global Sales](#)
- [News/Events](#)
- Useful Links---
- [RoHS](#)

**Quick Reference**

Search by part #

Check distributor part inventory

**Stock Check**

**Products**

Browse Heat sinks

- By Device -
- By Product Line -
- Attachment Methods -
- Interface Materials -
- Accessories -

**Useful Links**

- [Building a part #](#)
- [Catalog Request](#)
- [Directions](#)
- [Find Distributor](#)
- [Find Sales Associate](#)
- [How to order?](#)
- [MSDS Safety Sheets](#)
- [Part # Cross Ref](#)
- [Quote Request](#)
- [RoHS Initiative](#)
- [Sample Request](#)

[Products](#) / [BGA](#) / [Radial Fins](#)

## Radial Fin Heat Sinks for Microprocessors

- Bond-on heat sinks for leadless chip carriers and flat packs.
- Primarily designed for 68-position devices.
- The 2283 is ideally suited to limited board space applications with high air flow.

**Part Number: 2283BG**

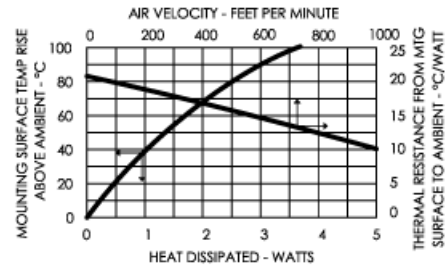
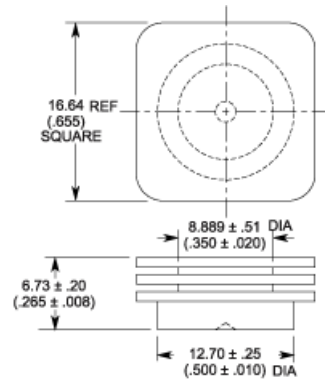

**Part Number: 2286BG<**

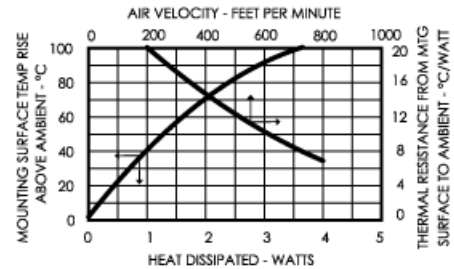
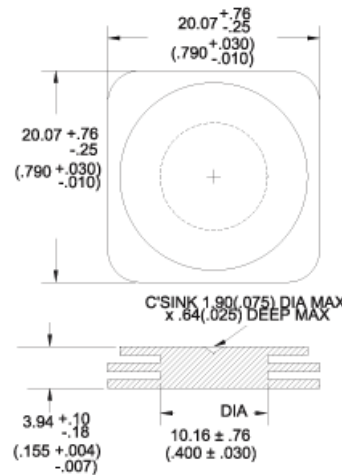

Part Number: 2288BG

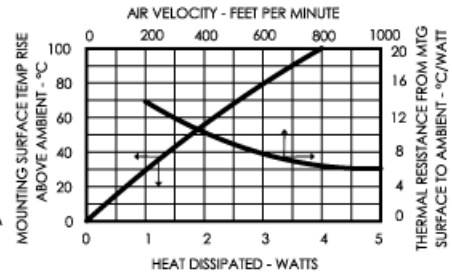
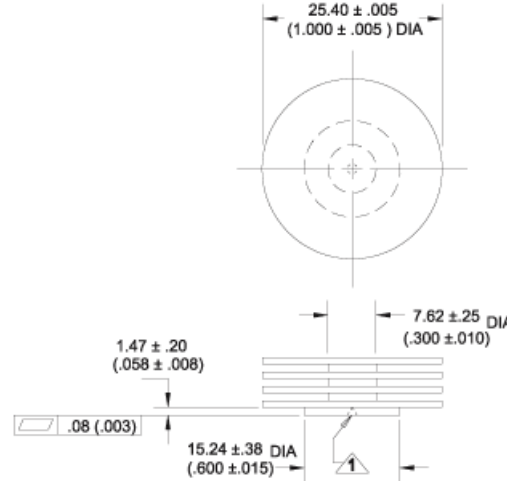

Part Number: 2292BG

RoHS Compliant

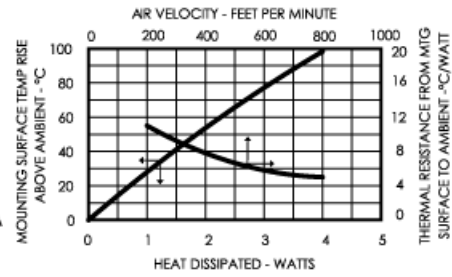
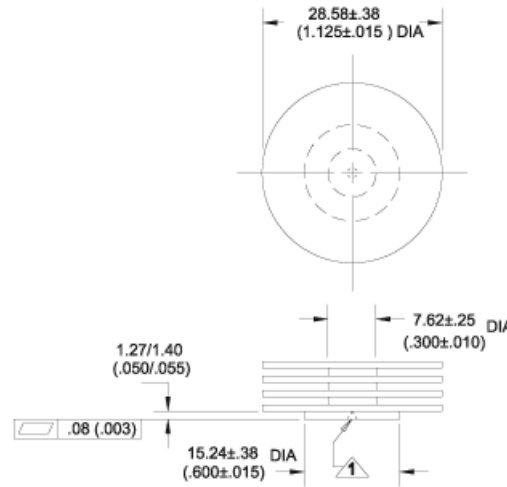

Part Number: 2296BG



