

LOC		DIST		REVISIONS			
P	LTN	DESCRIPTION	DATE	DWN	APVD		
U		REV PER ECO 16-003731	3-14-16	CT	RG		

AI CAVITY IDENTIFICATION
150 POSITION INSERT
2 PLC

.825 [20.95]
.825 [20.95]
3.225 [81.91]

AI CAVITY IDENTIFICATION
68Q2 INSERT ASSY

.186±.002 [4.72±0.05]
.426±.002 [10.82±0.05]

.360±.002 [9.14±0.05]
∅.098±.001 [2.5±0.02] ALIGNMENT HOLE
.200 [5.08] MIN DEEP

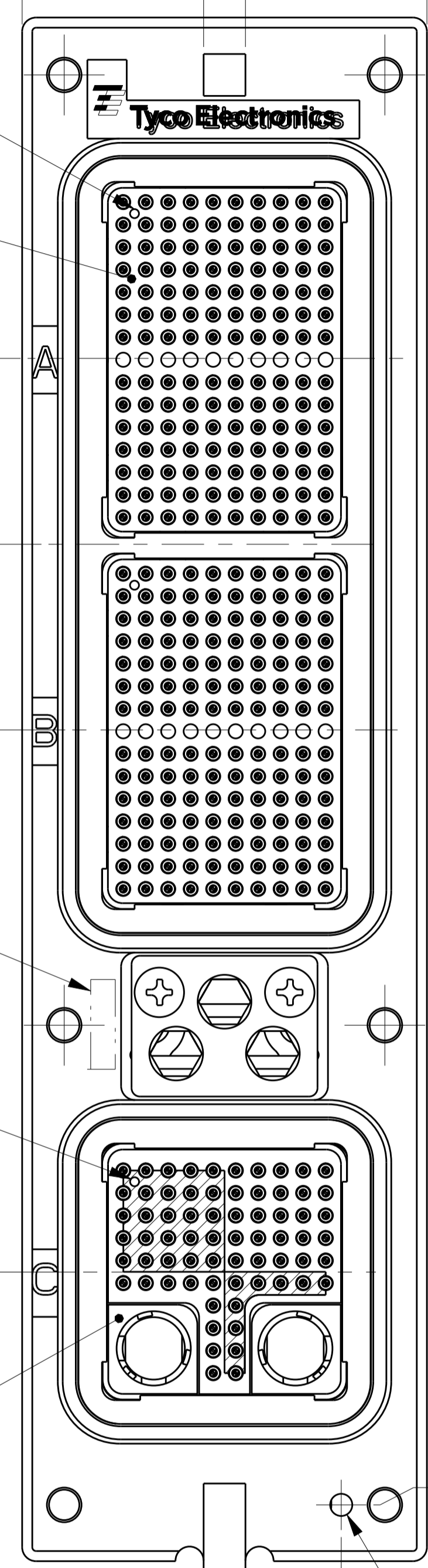

6.617±.010 [168.07±0.25]

.455 [11.56]
.060 [1.52]
1.075 [27.31]

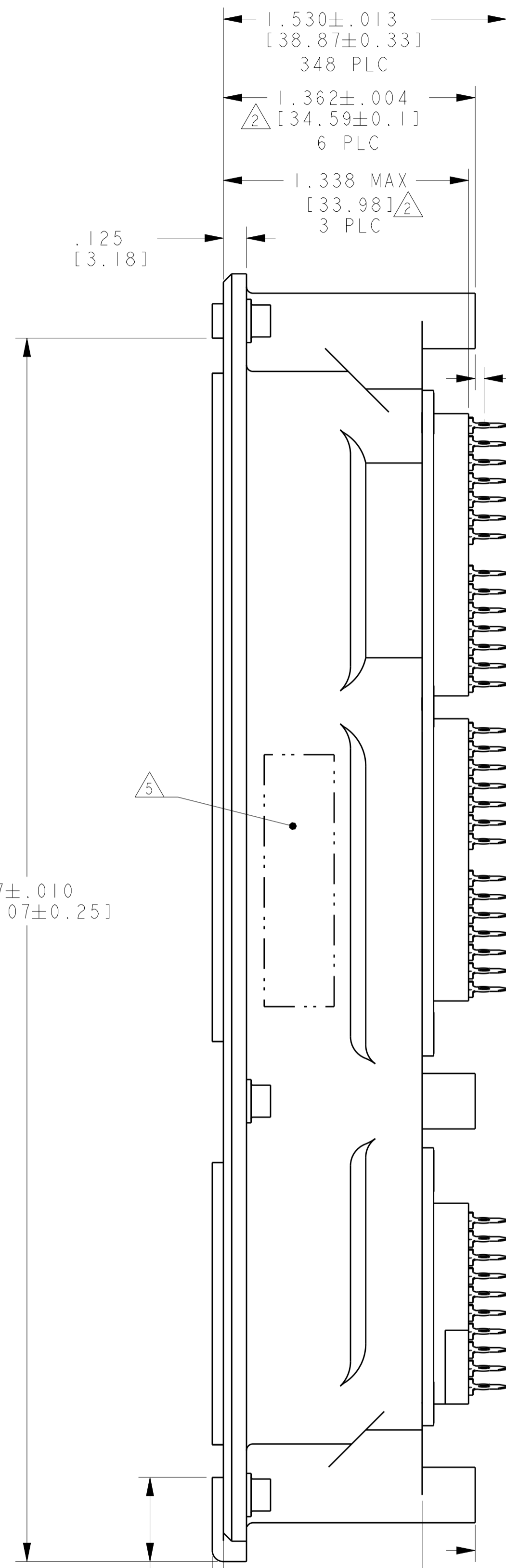

.048±.013 [1.22±0.33] (STANDOFF TO C/L OF EON)

6.965±.010 [176.91±0.25]

6.350 [161.29]

.360 [9.14]

1.426 [36.22] 3 PLC

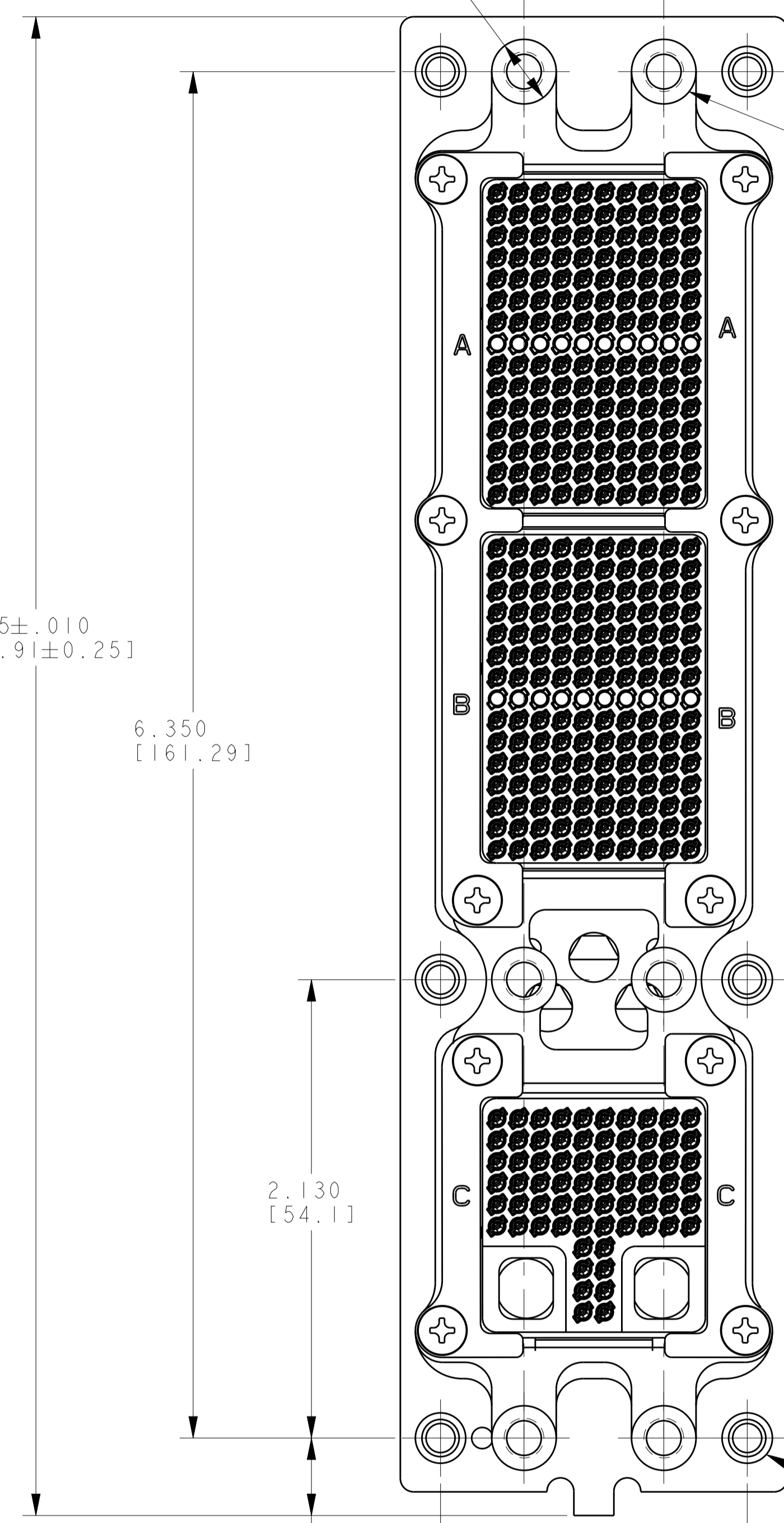

STANDOFF FOR P.C. BOARD MOUNTING WITH M3 X 0.5 THREADED INSERT 6 PLC

M3 X 0.5 CLINCH NUT 6 PLC

SUPERSEDED BY 2101004-2

348	"00"	2101004-4
368	"00"	2101004-3
348	"00"	2101004-2
348	"00"	2101004-1
SZ 22 CONTACT QUANTITY		KEYING POSITION $\Delta 10$ PART NO.

THIS DRAWING IS A CONTROLLED DOCUMENT.		DWN: C.C. THOMAS 03NOV2008	TE Connectivity
DIMENSIONS: INCHES(mm)		CHK: K. HOGAN 03NOV2008	
TOLERANCES UNLESS OTHERWISE SPECIFIED:		APVD: K. HOGAN 03NOV2008	NAME: RECEPTACLE ASSEMBLY, SIZE 2, ARINC 600 WITH PRESS FIT CONTACTS (150/150/68Q2)
0 PLC ± 1 PLC ± 2 PLC ± 3 PLC ±.005 (0.13) 4 PLC ± ANGLES ±		PRODUCT SPEC	
MATERIAL: SEE CALLOUTS		APPLICATION SPEC	RESTRICTED TO
FINISH: SEE CALLOUTS		WEIGHT	SIZE: A100779
CUSTOMER DRAWING		SCALE: 2:1	SHEET 1 OF 2

LOC	DIST	REV	DATE	BY	APPV
-	-	1			
		2			

- RECEPTACLE IS INTERMATEABLE TO ARINC 600 STYLE SIZE 2 PLUG ASSEMBLY
- ASSEMBLED CONNECTOR FEATURES COMPLY WITH ARINC 600 SPECIFICATION EXCEPT AS NOTED.
- ASSEMBLED CONNECTOR IS IN AGREEMENT, AS NOTED, WITH THALES TECHNICAL PROCUREMENT SPECIFICATION J54625AA-REV-02 AND CUSTOMER PURCHASING REQUIREMENTS SPECIFICATION 128-1089.
- THE FOLLOWING POSTED QUADRAx PIN CONTACTS FOR THE 68Q2 INSERT ARE AVAILABLE BUT NOT INCLUDED, TE PART NO. 1445626-8. THE CONTACTS ARE RoHS COMPLIANT AND Sn DIPPED.
 - (4A) THE MINIMUM POST EXTENSION BEYOND STANDOFF IS: .190 [4.83].
 - (4B) THE MAXIMUM POST EXTENSION FROM THE FRONT FACE IS: 1.624 [41.25]
- MANUFACTURERS PART NO. AND DATE CODE (YY-WW) MARKED IN AREA SHOWN.
- ESTIMATED WEIGHT OF CONNECTOR ASSEMBLY AS SHOWN: 290 GRAMS.
- MAX LOCKING TORQUE FOR M3 CLINCH NUTS: 0.34 N-m (3.0 in-lbf)
 MAX LOCKING TORQUE FOR M3 THREADED INSERTS: 0.45 N-m (4.0 in-lbf)
 MAX LOCKING TORQUE IS VALID FOR FIRST CYCLE ONLY. MAX LOCKING TORQUE REFERS TO THE TORQUE REQUIRED TO OVERCOME THE LOCKING FEATURE OF THE CLINCH NUT OR THREADED INSERT. TORQUE VALUES ARE FOR REFERENCE ONLY.
- CONDUCTIVE DUST COVER INSTALLED FOR SHIPPING. (NOT SHOWN)
- EYE OF THE NEEDLE CONTACT DESIGN CONSIDERATIONS:
 - (A) PCB HOLE DIAMETER: 0.90mm PER IEC 60352-5
 - (B) MINIMUM PCB THICKNESS: .063 [1.6]
 - (C) PCB PLATING: Sn PLATE RECOMMENDED
 - (D) NORMAL INSERTION FORCE: 8 lb MAX PER CONTACT;
900 lb AVERAGE PER 150 POSITION INSERT ASSEMBLY
- KEYING SHOWN IN POSITION "01" FOR REFERENCE ONLY. KEYING HARDWARE IS INCLUDED BUT SHIPPED UNASSEMBLED.
- CONNECTOR PACKAGING SHALL HAVE A LABEL WHICH WILL INCLUDE, AT A MINIMUM, THE THALES PART NUMBER, THE TE PART NUMBER AND THE MANUFACTURING DATE CODE.
- RoHS CODE IS "L" AS DEFINED IN TEC 238-2 DUE TO HEXAVALENT CHROMATE CONVERSION FINISH ON SHELL AND RETAINER PLATES.
- TE LOGO APPEARS IN THIS APPROXIMATE LOCATION ON SHELLS MACHINED FROM BILLET.
- ASSEMBLY SHOWN WITH DIE-CAST SHELL. ASSEMBLIES WITH MACHINED SHELLS MAY VARY SLIGHTLY IN APPEARANCE.

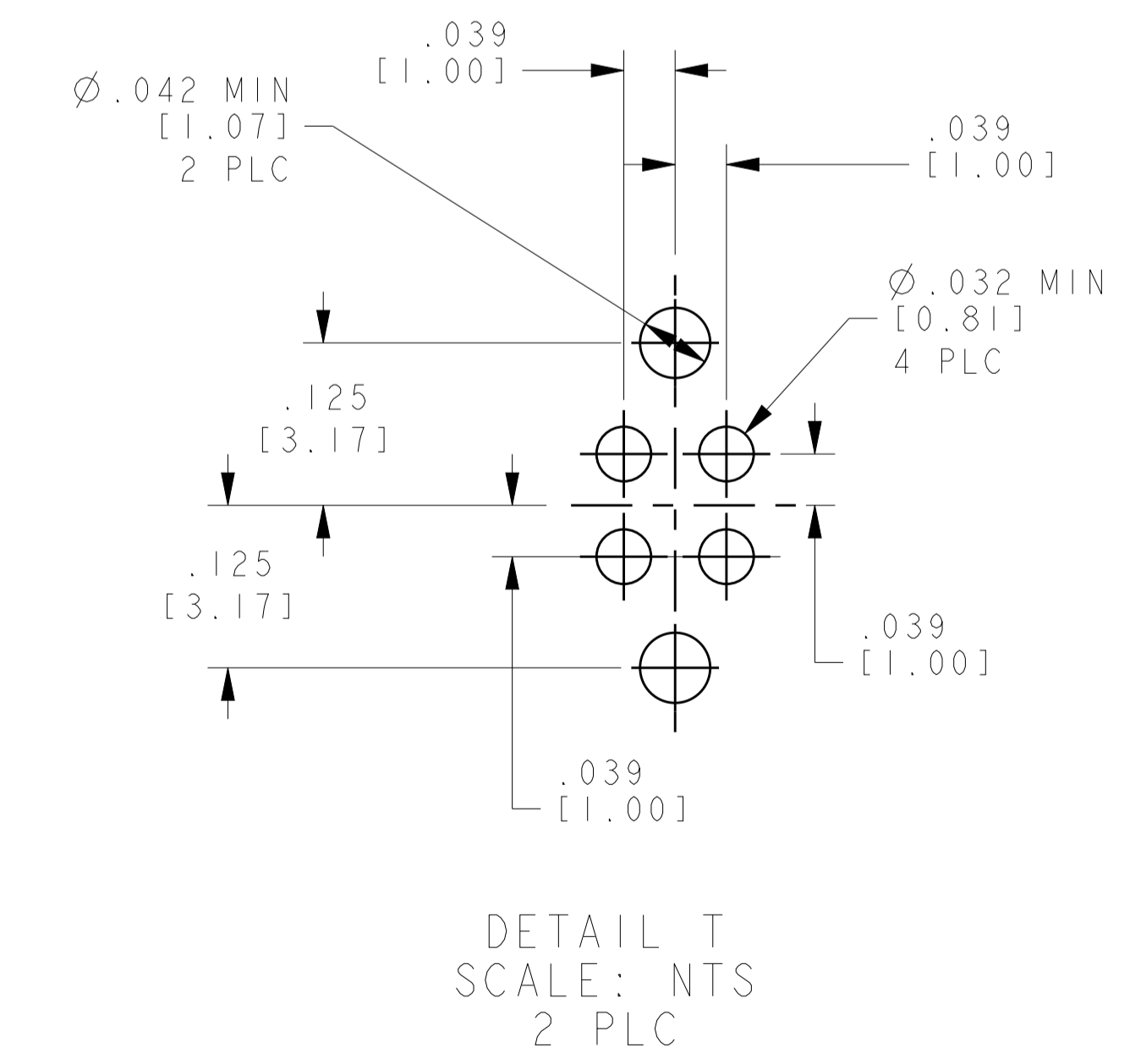
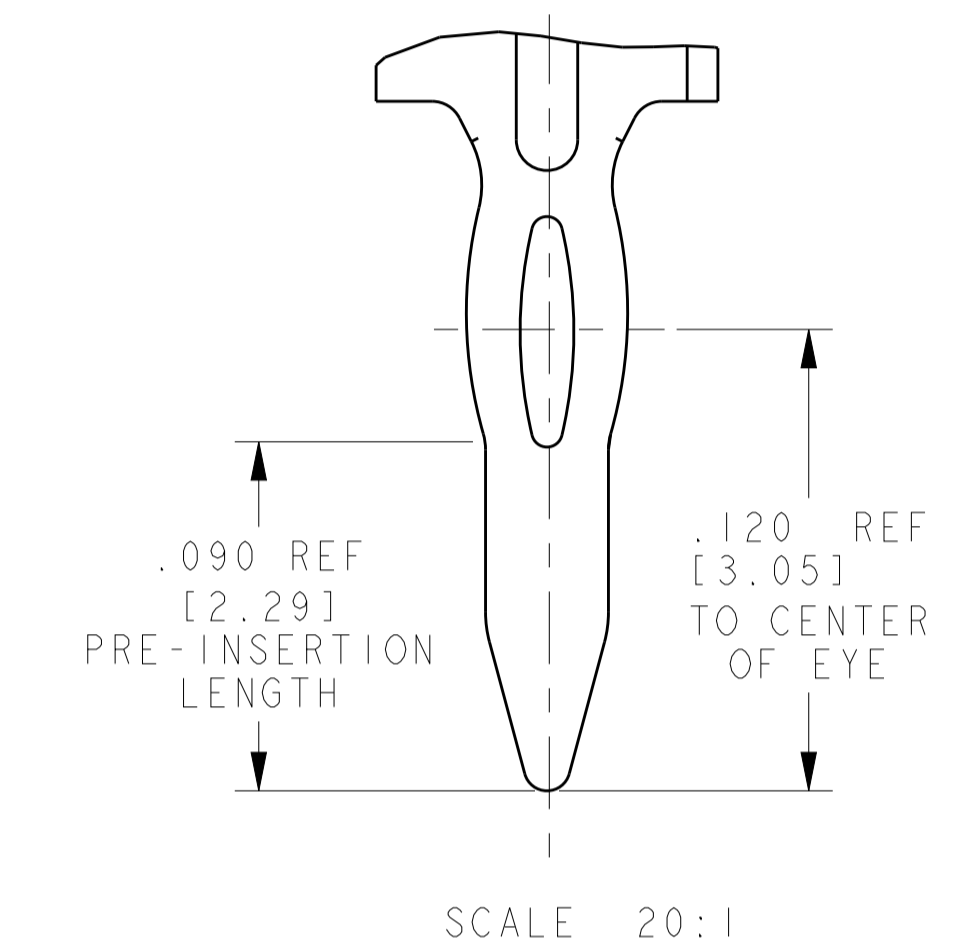
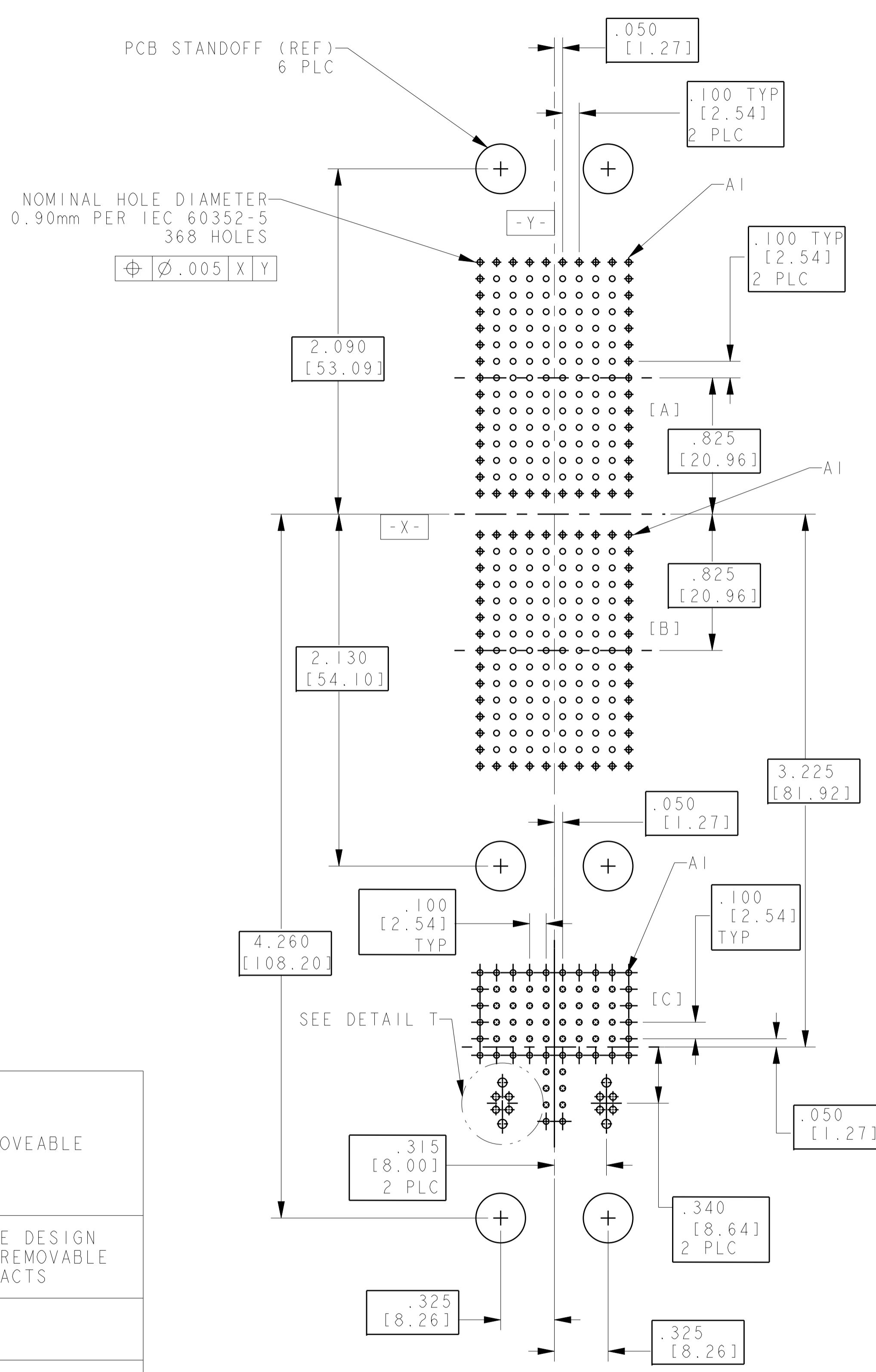

RECOMMENDED P.C. BOARD LAYOUT
SCALE NTS
(BACK VIEW)

COMPONENT	MATERIAL	FINISH	REMARKS
SIZE 22 SOCKET CONTACTS QTY = 348 (-2) QTY = 368 (-3)	BODY: COPPER ALLOY HOOD: STAINLESS STEEL	BODY: .000050 [1.27um] MIN GOLD ON MATING TINES, Sn ON EON TAIL, BOTH OVER NICKEL PLATE HOOD: PASSIVATED	NON REMOVEABLE
150 POSITION INSERT 2 PLC	THERMOPLASTIC	NONE	ONE PIECE DESIGN WITH NON-REMOVABLE CONTACTS
M3 THREADED INSERT 6 PLC	STAINLESS STEEL	DRY FILM LUBRICANT	
M3 CLINCH NUT 6 PLC	STEEL	ZINC PLATED WITH SUPP YELLOW TRIVALENT CHROMATE	
68Q2 INSERT ASSY	THERMOPLASTIC	NONE	SIGNAL CONTACTS NON-REMOVABLE QUADRAx CONTACTS FRONT RELEASE/REMOVE
SHELL & RETENTION PLATES	ALUMINUM ALLOY PER ASTM-B-85 OR ASTM B 211, 6061T6 OR ASTM B 209, 2024T4	FOR -2 & -3 CHROMATE CONVERSION PER MIL-C-5541 TYPE I CLASS 1A FOR -4 CHROMATE CONVERSION PER MIL-C-5541 TYPE II, CLASS 3	

THIS DRAWING IS A CONTROLLED DOCUMENT.

DIMENSIONS: INCHES(mm)	TOLERANCES UNLESS OTHERWISE SPECIFIED:	0 PLC ± 1 PLC ± 2 PLC ± 3 PLC ±.005 (0.13) 4 PLC ± ANGLES ±	DWN: C.C. THOMAS 03NOV2008 CHK: K. HOGAN 03NOV2008 APPV: K. HOGAN 03NOV2008	NAME: RECEPTACLE ASSEMBLY, SIZE 2, ARINC 600 WITH PRESS FIT CONTACTS (150/150/68Q2)
MATERIAL: SEE CALLOUTS	FINISH: SEE CALLOUTS	WEIGHT: -	SIZE: A100779	DRAWING NO: C=2101004
CUSTOMER DRAWING			SCALE: 2:1	SHEET 2 OF 2 REV U

STE TE Connectivity