

Product Specification

RoHS-6 Compliant

10Gb/s 850nm Multimode Datacom XFP Optical Transceiver

FTLX8511D3

PRODUCT FEATURES

- Hot-pluggable XFP footprint
- Supports 9.95Gb/s to 10.5Gb/s bit rates
- Power dissipation <1.5W
- RoHS-6 compliant (lead-free)
- Temperature range 0°C to 70°C
- Single power supply: 3.3V
- Maximum link length of 300m
- Uncooled 850nm VCSEL laser.
- Duplex LC connector
- No Reference Clock required
- Built-in digital diagnostic functions
- Standard bail release mechanism



APPLICATIONS

- 10GBASE-SR/SW 10G Ethernet
- 1200-Mx-SN-I 10G Fibre Channel

Finisar's FTLX8511D3 Small Form Factor 10Gb/s (XFP) transceivers are compliant with the current XFP Multi-Source Agreement (MSA) Specification¹. They comply with 10-Gigabit Ethernet 10GBASE-SR/SW per IEEE 802.3ae and 10G Fibre Channel 1200-Mx-SN-I. Digital diagnostics functions are available via a 2-wire serial interface, as specified in the XFP MSA. The transceiver is RoHS compliant and lead free per Directive 2002/95/EC³, and Finisar Application Note AN-2038⁴.

PRODUCT SELECTION

FTLX8511D3

I. Pin Descriptions

Pin	Logic	Symbol	Name/Description	Ref.
1		GND	Module Ground	1
2		VEE5	Optional –5.2 Power Supply – Not required	
3	LVTTL-I	Mod-Desel	Module De-select; When held low allows the module to respond to 2-wire serial interface commands	
4	LVTTL-O	Interrupt	Interrupt (bar); Indicates presence of an important condition which can be read over the serial 2-wire interface	2
5	LVTTL-I	TX_DIS	Transmitter Disable; Transmitter laser source turned off	
6		VCC5	+5 Power Supply – Not required	
7		GND	Module Ground	1
8		VCC3	+3.3V Power Supply	
9		VCC3	+3.3V Power Supply	
10	LVTTL-I	SCL	Serial 2-wire interface clock	2
11	LVTTL-I/O	SDA	Serial 2-wire interface data line	2
12	LVTTL-O	Mod_Abs	Module Absent; Indicates module is not present. Grounded in the module.	2
13	LVTTL-O	Mod_NR	Module Not Ready; Finisar defines it as a logical OR between RX_LOS and Loss of Lock in TX/RX.	2
14	LVTTL-O	RX_LOS	Receiver Loss of Signal indicator	2
15		GND	Module Ground	1
16		GND	Module Ground	1
17	CML-O	RD-	Receiver inverted data output	
18	CML-O	RD+	Receiver non-inverted data output	
19		GND	Module Ground	1
20		VCC2	+1.8V Power Supply – Not required	
21	LVTTL-I	P_Down/RST	Power Down; When high, places the module in the low power stand-by mode and on the falling edge of P_Down initiates a module reset Reset; The falling edge initiates a complete reset of the module including the 2-wire serial interface, equivalent to a power cycle.	
22		VCC2	+1.8V Power Supply – Not required	
23		GND	Module Ground	1
24	PECL-I	RefCLK+	Reference Clock non-inverted input, AC coupled on the host board – Not required	3
25	PECL-I	RefCLK-	Reference Clock inverted input, AC coupled on the host board – Not required	3
26		GND	Module Ground	1
27		GND	Module Ground	1
28	CML-I	TD-	Transmitter inverted data input	
29	CML-I	TD+	Transmitter non-inverted data input	
30		GND	Module Ground	1

Notes:

1. Module circuit ground is isolated from module chassis ground within the module.
2. Open collector; should be pulled up with 4.7kΩ – 10kΩ on host board to a voltage between 3.15V and 3.6V.
3. A Reference Clock input is not required by the FTLX8511D3. If present, it will be ignored.

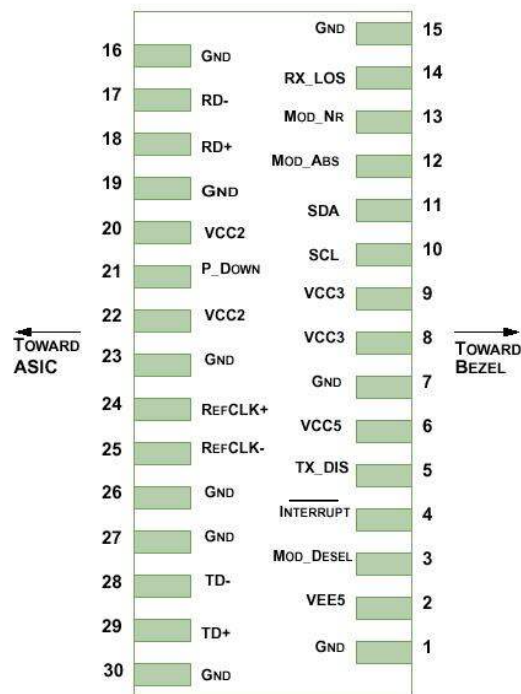

Diagram of Host Board Connector Block Pin Numbers and Name

II. Absolute Maximum Ratings

Parameter	Symbol	Min	Typ	Max	Unit	Ref.
Maximum Supply Voltage	Vcc3	-0.5		4.0	V	
Storage Temperature	T _S	-40		85	°C	
Case Operating Temperature	T _{OP}	0		70	°C	

III. Electrical Characteristics (T_{OP} = 0 to 70 °C, V_{CC3} = 3.13 to 3.45 Volts)

Parameter	Symbol	Min	Typ	Max	Unit	Ref.	
Supply Voltage	V _{cc3}	3.13		3.45	V		
Supply Current	I _{cc3}			400	mA		
Module total power	P			1.5	W	1	
Transmitter							
Input differential impedance	R _{in}		100		Ω	2	
Differential data input swing	V _{in,pp}	120		1000	mV		
Transmit Disable Voltage	V _D	2.0		V _{cc}	V	3	
Transmit Enable Voltage	V _{EN}	GND		GND+ 0.8	V		
Transmit Disable Assert Time				10	us		
Receiver							
Differential data output swing	V _{out,pp}	600	650	800	mV	4	
Data output rise time	t _r			40	ps	5	
Data output fall time	t _f			40	ps	5	
LOS Fault	V _{LOS fault}	V _{cc} – 0.5		V _{ccHOST}	V	6	
LOS Normal	V _{LOS norm}	GND		GND+0.5	V	6	
Power Supply Rejection	PSR	See Note 6 below					7

Notes:

1. Maximum total power value is specified across the full temperature and voltage range.
2. After internal AC coupling.
3. Or open circuit.
4. Into 100 ohms differential termination.
5. 20 – 80 %.
6. Loss Of Signal is open collector to be pulled up with a 4.7kΩ – 10kΩ resistor to 3.15 – 3.6V. Logic 0 indicates normal operation; logic 1 indicates no signal detected.
7. Per Section 2.7.1. in the XFP MSA Specification¹.

IV. Optical Characteristics (T_{OP} = 0 to 70 °C, V_{CC3} = 3.13 to 3.45 Volts)

Parameter	Symbol	Min	Typ	Max	Unit	Ref.	
Transmitter							
Optical Modulation Amplitude (OMA)	P _{OMA}	-2.8	-1.5		dBm		
Average Optical Power	P _{AVE}	-5.0		-1.0		1	
Optical Wavelength	λ	840	850	860	nm		
RMS Spectral Width	$\Delta\lambda_{rms}$		0.4	0.45	dB		
Optical Extinction Ratio	ER	3.0	5.5		dB		
Transmitter and Dispersion Penalty	TDP			3.9	dB		
Average Launch power of OFF transmitter	P _{OFF}			-30	dBm		
Tx Jitter	T _{Xj}	Per 802.3ae requirements					
Encircled Flux	<4.5 μ m			30	%	2	
	<19 μ m	86					
Relative Intensity Noise	RIN ₁₂ OMA			-128	dB/Hz		
Receiver							
Receiver Sensitivity (OMA) @ 10.5Gb/s	R _{SENS1}			-11.1	dBm	3	
Stressed Receiver Sensitivity (OMA) @ 10.3Gb/s	R _{SENS2}			-7.5	dBm	4	
Maximum Input Power	P _{MAX}	+0.5			dBm		
Wavelength Range	λ_C	840		860	nm		
Receiver Reflectance	R _{FX}			-12	dB		
LOS De-Assert	LOS _D	-30			dBm		
LOS Assert	LOS _A		-20	-12	dBm		
LOS Hysteresis		0.5			dB		

Notes:

1. Average power figures are informative only, per IEEE 802.3ae.
2. Measured into Type A1a (50/125 μ m multimode) fiber per ANSI/TIA/EIA-455-203-2.
3. Measured with worst ER; BER<10⁻¹²; 2³¹ – 1 PRBS.
4. Per IEEE 802.3ae.

V. General Specifications

Parameter		Symbol	Min	Typ	Max	Units	Ref.
Bit Rate		BR	9.95		10.5	Gb/s	1
Bit Error Ratio		BER			10^{-12}		2
Maximum Supported Distances							
Fiber Type	850nm OFL Bandwidth						
62.5 μ m	160MHz-km	Lmax			26	m	
	OM1 200MHz-km				33		
50 μ m	400MHz-km	Lmax			66	m	
	OM2 500MHz-km				82		
	OM3 2000MHz-km				300		

Notes:

- 10GBASE-SR/SW, 1200-Mx-SN-I
- Tested with a $2^{31} - 1$ PRBS

VI. Environmental Specifications

Finisar XFP transceivers have an operating temperature range from 0°C to +70°C case temperature.

Parameter	Symbol	Min	Typ	Max	Units	Ref.
Case Operating Temperature	T _{op}	0		70	°C	
Storage Temperature	T _{sto}	-40		85	°C	

VII. Regulatory Compliance

Finisar XFP transceivers are Class 1 Laser Products. They are certified per the following standards:

Feature	Agency	Standard	Certificate Number
Laser Eye Safety	FDA/CDRH	IEC60825	9210176-77
Laser Eye Safety	TÜV	EN60825	72052602
Electrical Safety	TÜV	EN 60950	72052602
Electrical Safety	UL/CSA	CLASS 3862.07 CLASS 3862.87	1439230

Copies of the referenced certificates are available at Finisar Corporation upon request.

VIII. Digital Diagnostic Functions

As defined by the XFP MSA¹, Finisar XFP transceivers provide digital diagnostic functions via a 2-wire serial interface, which allows real-time access to the following operating parameters:

- Transceiver temperature
- Laser bias current
- Transmitted optical power
- Received optical power
- Transceiver supply voltage

It also provides a sophisticated system of alarm and warning flags, which may be used to alert end-users when particular operating parameters are outside of a factory-set normal range.

The operating and diagnostics information is monitored and reported by a Digital Diagnostics Transceiver Controller (DDTC) inside the transceiver, which is accessed through the 2-wire serial interface. When the serial protocol is activated, the serial clock signal (SCL pin) is generated by the host. The positive edge clocks data into the XFP transceiver into those segments of its memory map that are not write-protected. The negative edge clocks data from the XFP transceiver. The serial data signal (SDA pin) is bi-directional for serial data transfer. The host uses SDA in conjunction with SCL to mark the start and end of serial protocol activation. The memories are organized as a series of 8-bit data words that can be addressed individually or sequentially. The 2-wire serial interface provides sequential or random access to the 8 bit parameters, addressed from 000h to the maximum address of the memory.

For more detailed information including memory map definitions, please see Finisar Application Note AN-2035 “Digital Diagnostic Monitoring Interface for XFP Optical Transceivers”, or the XFP MSA Specification¹.

IX. Mechanical Specifications

Finisar’s XFP transceivers are compliant with the dimensions defined by the XFP Multi-Sourcing Agreement (MSA). Bail color is beige.

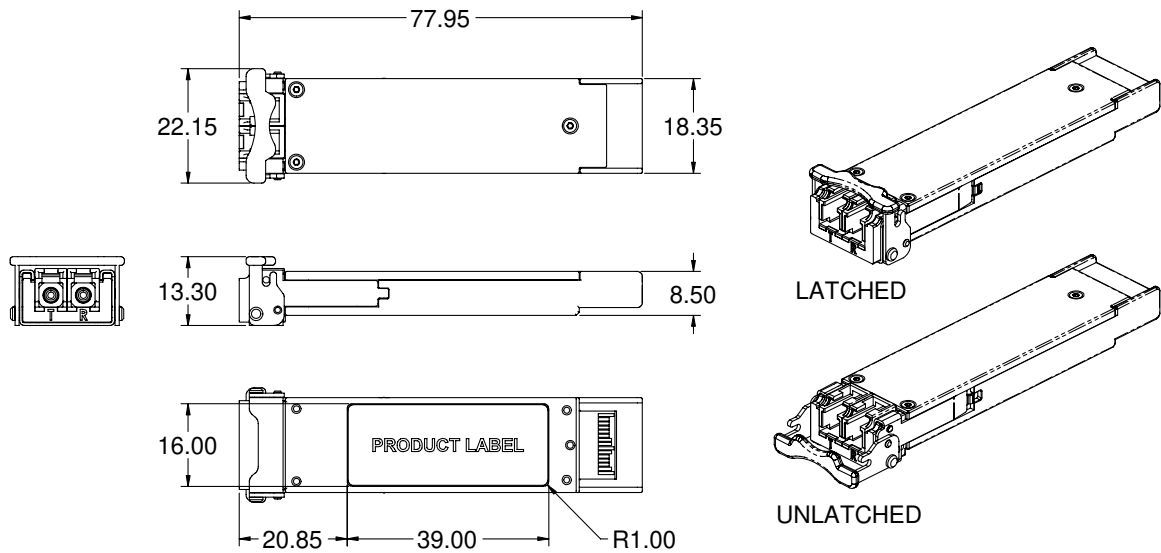

XFP Transceiver (dimensions are in mm)

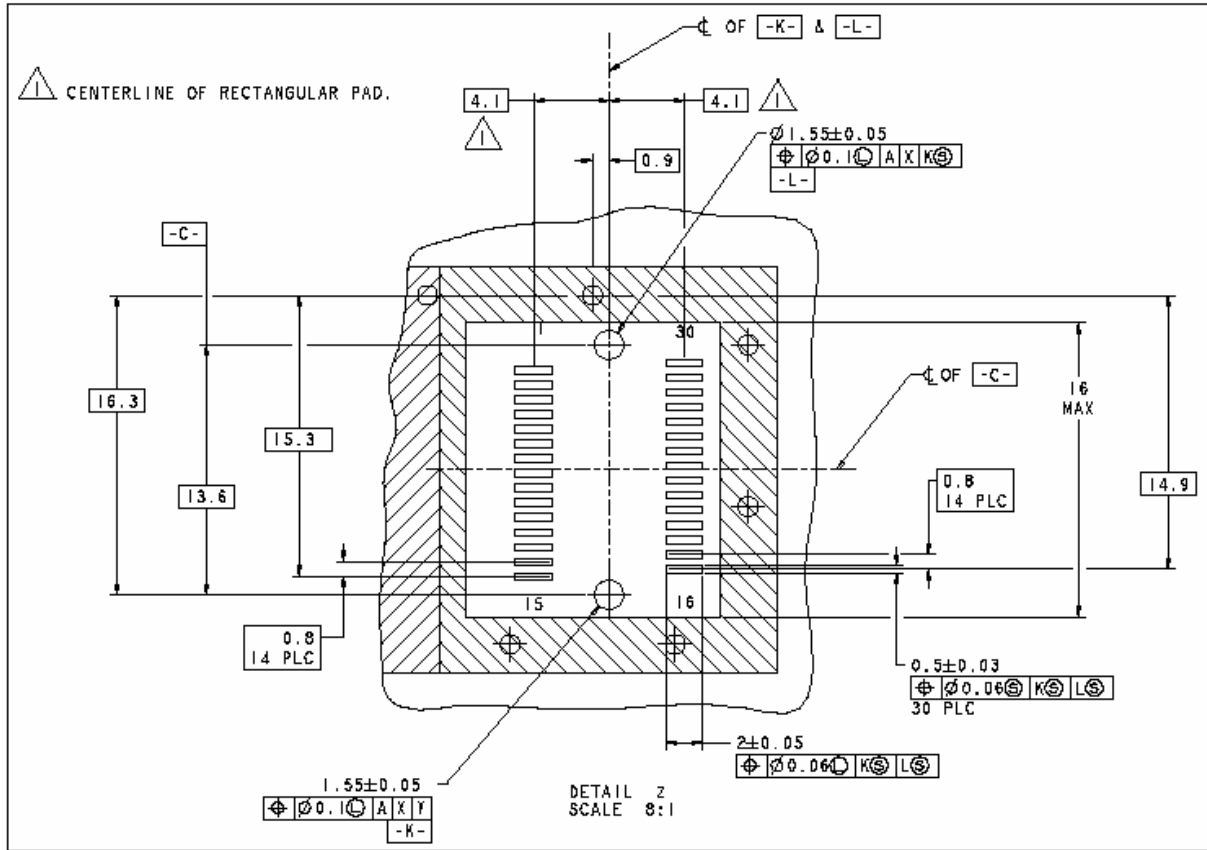

XFP Detail Host Board Mechanical Layout (dimensions are in mm)

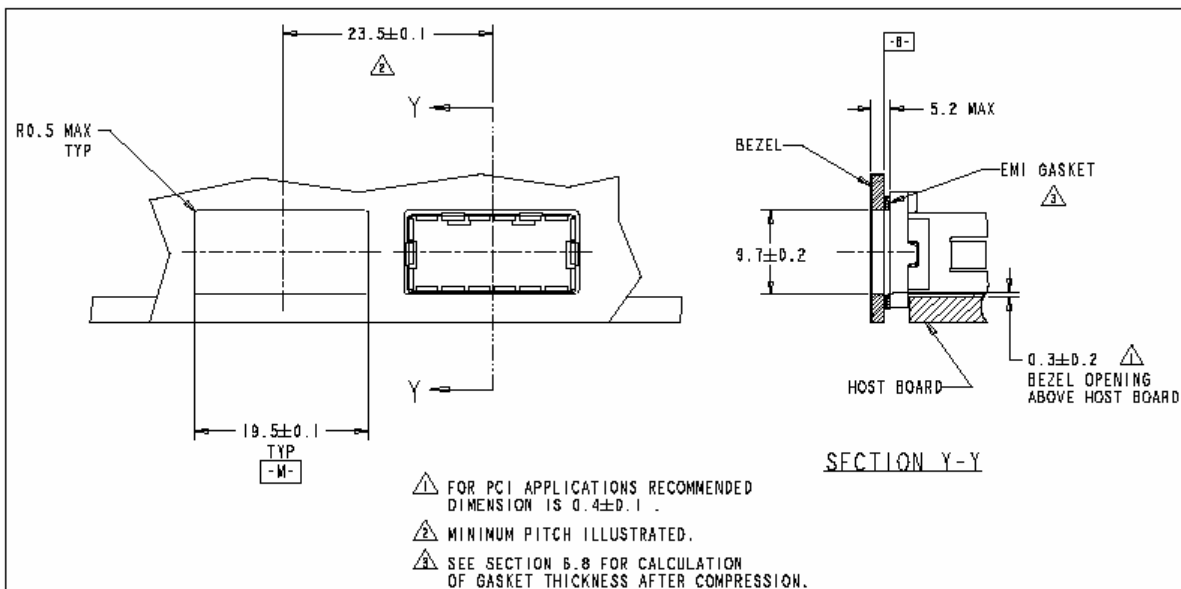

XFP Recommended Bezel Design (dimensions are in mm)

XI. References

1. 10 Gigabit Small Form Factor Pluggable Module (XFP) Multi-Source Agreement (MSA), Rev 4.5 - August 2005. Documentation is currently available at <http://www.xfpmsa.org/>
2. Application Note AN-2035: “Digital Diagnostic Monitoring Interface for XFP Optical Transceivers” – Finisar Corporation, December 2003
3. Directive 2002/95/EC of the European Council Parliament and of the Council, “on the restriction of the use of certain hazardous substances in electrical and electronic equipment”. January 27, 2003.
4. “Application Note AN-2038: Finisar Implementation Of RoHS Compliant Transceivers”, Finisar Corporation, January 21, 2005.

Revision	Date	Description
A1	2/12/2006	<ul style="list-style-type: none"> • Document created.
A2	4/21/2006	<ul style="list-style-type: none"> • Added RoHS-6 Compliant to document title. • Added references 3 and 4 • Corrected OM1 fiber Type
A3	12/12/2006	<ul style="list-style-type: none"> • Updated mechanical specifications • Updated electrical characteristics
B	1/11/2007	<ul style="list-style-type: none"> • Updated operating case temperature range • Updated product photo
C	5/30/2007	<ul style="list-style-type: none"> • Added Average Tx Optical Power for information only

XII. For More Information

Finisar Corporation
 1389 Moffett Park Drive
 Sunnyvale, CA 94089-1133
 Tel. 1-408-548-1000
 Fax 1-408-541-6138
sales@finisar.com
www.finisar.com