

GENERAL DESCRIPTION

The AD8331 evaluation board is a platform for testing and evaluating the AD8331 variable gain amplifier (VGA). The board is provided completely assembled and tested; therefore, the user only needs to connect an input signal, V_{GAIN} sources, and a single 5 V power supply.

USER SUPPLIED OPTIONAL COMPONENTS

As shown in the schematic in Figure 2 (fixed), the board has provisions for optional components. The basic components are shown in black, and the optional components, which can be installed at the user's discretion, are shown in grey.

The input impedance of the LNA is configured for 50 Ω to accommodate most signal generators and network analyzers. Input impedances up to 6 k Ω can be realized by changing the values of RFB and CSH. Consult the [AD8331](#) data sheet for details on this circuit feature. See Table 1 for typical values of input impedance and corresponding components.

Table 1. LNA External Component Values for Common Source Impedances

R_{IN} (Ω)	RFB (Ω , Nearest 1% Value)	CSH (pF)
50	274	22
75	412	12
100	562	8
200	1.13 k	1.2
500	3.01 k	None
6 k	∞	None

The board is designed for 0805 size surface-mount components. Space is provided for various popular configurations of overload diodes at locations D1, D2, or D3.

The LNA can be evaluated on its own. If so used alone, it must be ac-coupled with capacitors at its differential output. Typical values are 0.1 μ F, and they are installed at Position C1 and Position C2.

Resistors of 0 Ω are installed at R4 and R8, unless capacitive loads larger than 10 pF are connected to the SMA connectors, LON, and LOP (such as coaxial cables.) In that event, small value resistors (68 Ω to 100 Ω) must be installed at R4 and R8.

A resistor can be inserted at RCLMP if output clamping is desired. Consult the [AD8331](#) data sheet for appropriate values.

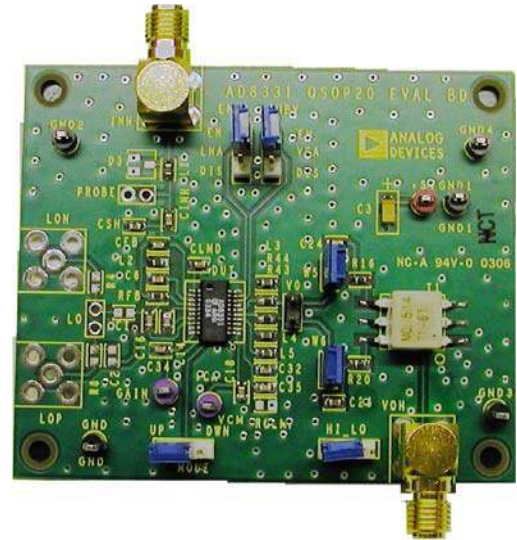

Figure 1. AD8331-EVAL Top View

The preferred signal detection method is a differential probe connected to VO, as shown in Figure 3. Single-ended loads can be connected using the board edge SMA connector, VOH. Be sure to take into account the 25.8 dB attenuation incurred when using the board in this manner.

MEASUREMENT SETUP

The basic board connection for measuring bandwidth is shown in Figure 3. A 5 V, 100 mA minimum power supply, and a low noise, voltage reference supply for GAIN is required. Table 2 lists jumpers, and Figure 3 shows their function and positions.

Table 2. Jumper Functions

No.	Function
ENBL	Enables the LNA when inserted in the top position
ENBV	Enables the VGA when inserted in the top position
W5, W6	Connects the AD8331's outputs to the SMA connectors
Mode	Bottom, gain increases with V_{GAIN} ; Top, gain decreases with V_{GAIN}
HI_LO	Top, HI gain; bottom, LO gain (shown in Hi gain position)

BOARD LAYOUT AND PARTS LIST

The evaluation board circuitry uses four conductor layers. The two inner layers are grounded, and all interconnecting circuitry is located on the outer layers. Figure 5 to Figure 8 illustrate the copper patterns. Table 3 is a part's list.

Rev. A

Information furnished by Analog Devices is believed to be accurate and reliable. However, no responsibility is assumed by Analog Devices for its use, nor for any infringements of patents or other rights of third parties that may result from its use. Specifications subject to change without notice. No license is granted by implication or otherwise under any patent or patent rights of Analog Devices. Trademarks and registered trademarks are the property of their respective owners.

AD8331-EVAL

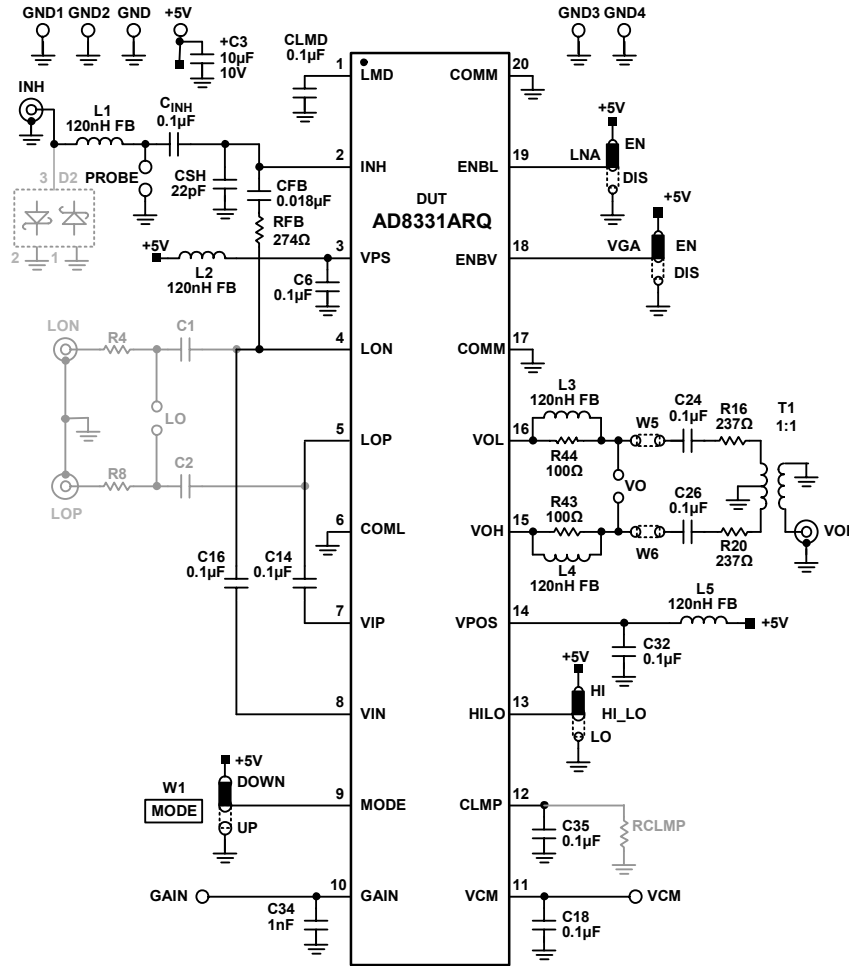

NOTES
1. COMPONENTS IN GREY ARE OPTIONAL AND USER SUPPLIED.

Figure 2. Schematic of Evaluation Board

04588-002

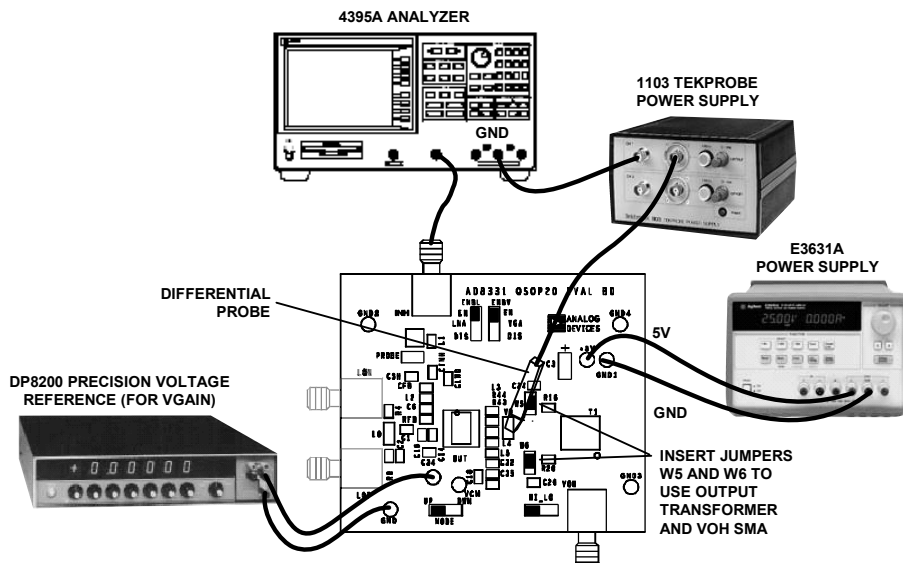

Figure 3. Typical Board Test Connections

04588-003

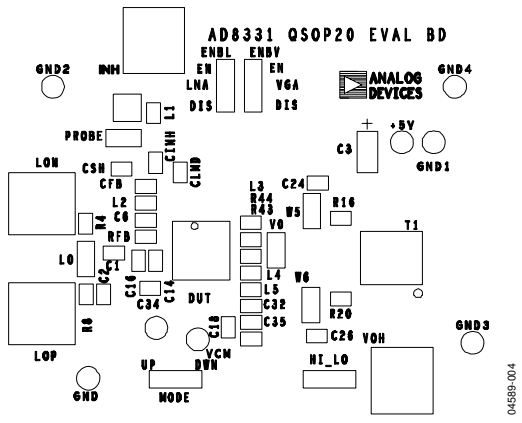

Figure 4. Top Silkscreen

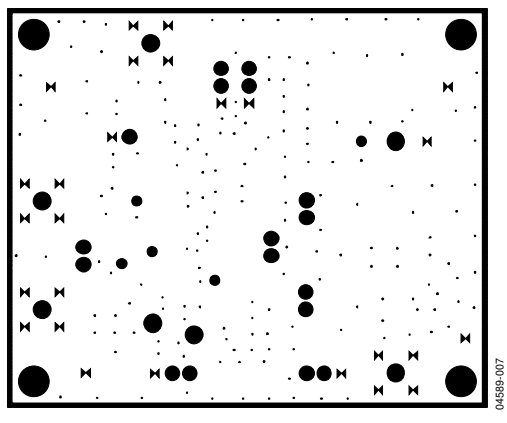

Figure 7. Internal Layer Ground

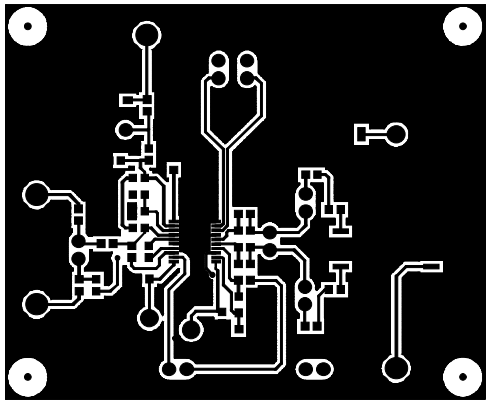

Figure 5. Primary Side Copper

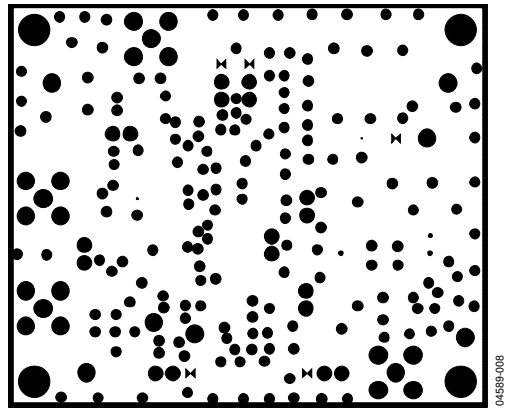

Figure 8. Power Plane

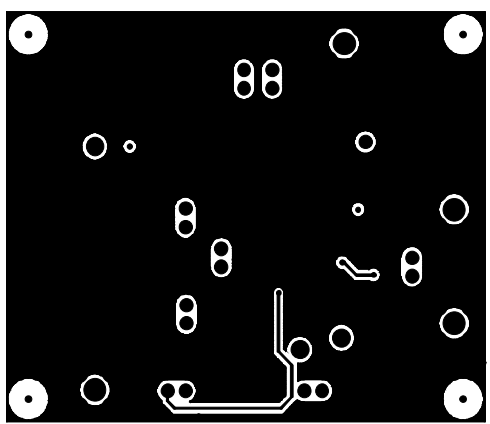

Figure 6. Secondary Side Copper

AD8331-EVAL

Table 3. Parts List

Qty	Name	Description	Reference Designation	Mfg.	Mfg. Part Number
5	Inductors	Ferrite Bead, 120 nH, 0603	L1, L2, L3, L4, L5	Murata	BLM18BA750SN1D
1	Resistor	SM, 274 Ω , 1%, 1/10 W, 0603	RFB	Panasonic	ERJ-3EKF2740V
2	Resistors	SM, 237 Ω , 1%, 1/10 W, 0603	R16, R20	Panasonic	ERJ-3EKF2370V
2	Resistors	SM, 100 Ω , 1%, 1/10 W, 0603	R43, R44	Panasonic	ERJ-3EKF1
1	Capacitor	0.018 μ F, 10%, X7R, 0603	CFB	Panasonic	ECJ-1VB1E183K
10	Capacitor	0.1 μ F, 50 V, 0603	C6, C14, C16, C18, C24, C26, C32, C35, C _{INH} , CLMD	Kemet	C0603C104K4RAC
1	Capacitor	1000 pF, 50 V, 0603	C34	Panasonic	ECJ-1VB2A102K
1	Capacitor	10 μ F, 10V Tantalum	C3	Nichicon	F931A106MAA
6	Shunt	Shunt	HI_LO (HI), MODE (UP), ENBL (EN), ENBV (EN), W5, W6	W. M. Berg	65474-001
1	Capacitor	22 pF, 50 V, 0603	CSH	Panasonic	ECJ-1VC1H220J
1	Transformer	RF, 0.015 MHz to 300 MHz	T1	Mini-Circuit	#T1-6T KK81
4	Bumper	Foot	Used as feet. Mount to wiring side of board at 4 corners	3M	SJ-67A11
1	Integrated Circuit	Variable Gain Amplifier	DUT	Analog Devices, Inc.	AD8331ARQ
3	Connector	2-Pin Header	VO, W5, W6	W. M. Berg	69157-102
4	Connector	3-Pin Header	ENBL, ENBV, HI_LO, MODE Fixed	Molex	22-11-2032
2	Connectors	SMA, Right Angle PC Mount	INH, VOH	Amphenol	901-143-6RFX
1	Test Point	Red Loop	+5V	Bisco	TP-104-01-02
5	Test Points	Black Loop	GND, GND 1, GND 2, GND 3, GND 4	Bisco	TP-104-01-00
1	Test Points	Purple Loop	VCM Fixed	Bisco	TP-104-01-07

ESD CAUTION

ESD (electrostatic discharge) sensitive device. Electrostatic charges as high as 4000 V readily accumulate on the human body and test equipment and can discharge without detection. Although this product features proprietary ESD protection circuitry, permanent damage may occur on devices subjected to high energy electrostatic discharges. Therefore, proper ESD precautions are recommended to avoid performance degradation or loss of functionality.



ORDERING GUIDE

Model	Description
AD8331-EVAL	Evaluation Board with AD8331ARQ