



# ±15kV ESD-Protected, 0.5µA, +3V to +5.5V, 1.5Mbps RS-232 Receivers in SOT23-5

## General Description

The MAX3180E–MAX3183E single RS-232 receivers in a SOT23-5 package are designed for space- and cost-constrained applications requiring minimal RS-232 communications. The receiver inputs are protected to ±15kV using IEC 1000-4-2 Air-Gap Discharge, to ±8kV using IEC 1000-4-2 Contact Discharge, and to ±15kV per the Human Body Model, ensuring compliance with international standards.

The devices minimize power and heat dissipation by consuming only 0.5µA supply current from a +3.0V to +5.5V supply, and they guarantee true RS-232 performance up to a 1.5Mbps data rate. The MAX3180E/MAX3182E feature a three-state TTL/CMOS receiver output that is controlled by an  $\overline{\text{EN}}$  logic input. The MAX3181E/MAX3183E feature an  $\overline{\text{INVALID}}$  output that indicates valid RS-232 signals at the receiver input for applications requiring automatic system wake-up. The MAX3182E/MAX3183E have a noninverting output, while the MAX3180E/MAX3181E have a standard inverting output.

## Applications

Diagnostic Ports  
Telecommunications  
Networking Equipment  
Set-Top Boxes  
Digital Cameras  
Hand-Held Equipment

## Features

- ♦ Tiny SOT23-5 Package
- ♦ ESD-Protected RS-232 Input
  - ±15kV—Human Body Model
  - ±8kV—IEC 1000-4-2, Contact Discharge
  - ±15kV—IEC 1000-4-2, Air-Gap Discharge
- ♦ 0.5µA Supply Current
- ♦ 1.5Mbps Guaranteed Data Rate
- ♦ Meets EIA/TIA-232 and V.28/V.24 Specifications Down to  $V_{CC} = +3.0V$
- ♦  $\overline{\text{INVALID}}$  Output Indicates Valid RS-232 Signal at Receiver Input (MAX3181E/MAX3183E)
- ♦ Three-State TTL/CMOS Receiver Output (MAX3180E/MAX3182E)
- ♦ Noninverting RS-232 Output (MAX3182E/MAX3183E)

## Ordering Information

PART	TEMP. RANGE	PIN-PACKAGE	TOP MARK
MAX3180EEUK-T	-40°C to +85°C	5 SOT23-5	ACHB
MAX3181EEUK-T	-40°C to +85°C	5 SOT23-5	ACHC
MAX3182EEUK-T	-40°C to +85°C	5 SOT23-5	ACHD
MAX3183EEUK-T	-40°C to +85°C	5 SOT23-5	ACHE

Pin Configurations/Functional Diagrams appear at end of data sheet.

## Selector Guide

PART	ESD PROTECTION (kV)	PACKAGE	SUPPLY CURRENT (µA)	$\overline{\text{EN}}$ INPUT	$\overline{\text{INVALID}}$ OUTPUT	INVERTING ROUT	NON-INVERTING ROUT
MAX3180E	±15	SOT23-5	0.5	✓	—	✓	—
MAX3181E	±15	SOT23-5	0.5	—	✓	✓	—
MAX3182E	±15	SOT23-5	0.5	✓	—	—	✓
MAX3183E	±15	SOT23-5	0.5	—	✓	—	✓



# ±15kV ESD-Protected, 0.5µA, +3V to +5.5V, 1.5Mbps RS-232 Receivers in SOT23-5

## ABSOLUTE MAXIMUM RATINGS

V<sub>CC</sub> to GND .....-0.3V to +6V  
 R<sub>IN</sub> to GND .....±25V  
 EN, R<sub>OUT</sub>,  $\overline{\text{INVALID}}$  to GND .....-0.3V to (V<sub>CC</sub> + 0.3V)  
 Continuous Power Dissipation (T<sub>A</sub> = +70°C)  
   SOT23-5 (derate 7.1mW/°C above +70°C).....571mW

Operating Temperature Range .....-40°C to +85°C  
 Storage Temperature Range .....-65°C to +150°C  
 Lead Temperature (soldering, 10sec) .....+300°C

*Stresses beyond those listed under "Absolute Maximum Ratings" may cause permanent damage to the device. These are stress ratings only, and functional operation of the device at these or any other conditions beyond those indicated in the operational sections of the specifications is not implied. Exposure to absolute maximum rating conditions for extended periods may affect device reliability.*

## ELECTRICAL CHARACTERISTICS

(V<sub>CC</sub> = +3.0V to +5.5V, T<sub>A</sub> = T<sub>MIN</sub> to T<sub>MAX</sub>, unless otherwise noted. Typical values are at V<sub>CC</sub> = +5.0V, T<sub>A</sub> = +25°C.) (Note 1)

PARAMETER	SYMBOL	CONDITIONS	MIN	TYP	MAX	UNITS
<b>DC CHARACTERISTICS</b>						
Supply Voltage	V <sub>CC</sub>		3.0		5.5	V
Supply Current	I <sub>CC</sub>	V <sub>CC</sub> = 3.3V or 5V, R <sub>IN</sub> = V <sub>CC</sub> or GND, no load		0.5	5.0	µA
<b>LOGIC INPUT (<math>\overline{\text{EN}}</math>)</b>						
Logic Threshold Low	V <sub>IL</sub>				0.8	V
Logic Threshold High	V <sub>IH</sub>	V <sub>CC</sub> = 3.3V	2.0			V
		V <sub>CC</sub> = 5.0V	2.4			
Leakage Current	I $\overline{\text{EN}}$			±0.01	±1.0	µA
<b>LOGIC OUTPUT</b>						
$\overline{\text{INVALID}}$ Output Voltage Low	V <sub>IOL</sub>	I <sub>SINK</sub> = 1.6mA			0.4	V
$\overline{\text{INVALID}}$ Output Voltage High	V <sub>IOH</sub>	I <sub>SOURCE</sub> = 1.0mA	V <sub>CC</sub> - 0.6			V
<b>RECEIVER INPUT</b>						
Input Voltage Range	V <sub>RIN</sub>		-25		25	V
Input Threshold Low	V <sub>ITL</sub>	V <sub>CC</sub> = 3.3V	0.6	1.2		V
		V <sub>CC</sub> = 5.0V	0.8	1.5		
Input Threshold High	V <sub>ITH</sub>	V <sub>CC</sub> = 3.3V		1.5	2.4	V
		V <sub>CC</sub> = 5.0V		1.8	2.7	
Input Hysteresis	V <sub>HYST</sub>			300		mV
R <sub>IN</sub> Threshold to $\overline{\text{INVALID}}$ Output High	V <sub>ITOH</sub>	Positive threshold			2.7	V
		Negative threshold	-2.7			
R <sub>IN</sub> Threshold to $\overline{\text{INVALID}}$ Output Low	V <sub>ITOL</sub>		-0.3		0.3	V
Input Resistance	R <sub>RIN</sub>		3	5	7	kΩ
<b>RECEIVER OUTPUT</b>						
Output Leakage Current	I <sub>ROUT</sub>	Receiver disabled		±0.05	±10	µA
Output Voltage Low	V <sub>OL</sub>	I <sub>SINK</sub> = 1.6mA			0.4	V
Output Voltage High	V <sub>OH</sub>	I <sub>SOURCE</sub> = 1.0mA	V <sub>CC</sub> - 0.6	V <sub>CC</sub> - 0.1		V

# ±15kV ESD-Protected, 0.5µA, +3V to +5.5V, 1.5Mbps RS-232 Receivers in SOT23-5

**MAX3180E-MAX3183E**

## ELECTRICAL CHARACTERISTICS (continued)

(V<sub>CC</sub> = +3.0V to +5.5V, T<sub>A</sub> = T<sub>MIN</sub> to T<sub>MAX</sub>, unless otherwise noted. Typical values are at V<sub>CC</sub> = +5.0V, T<sub>A</sub> = +25°C.) (Note 1)

PARAMETER	SYMBOL	CONDITIONS	MIN	TYP	MAX	UNITS
<b>TIMING CHARACTERISTICS</b>						
Maximum Data Rate		C <sub>L</sub> = 50pF	1.5			Mbps
Receiver Propagation Delay, High-to-Low	t <sub>PHL</sub>	R <sub>IN</sub> to R <sub>OUT</sub> ; C <sub>L</sub> = 150pF		0.15		µs
Receiver Propagation Delay, Low-to-High	t <sub>PLH</sub>	R <sub>IN</sub> to R <sub>OUT</sub> ; C <sub>L</sub> = 150pF		0.15		µs
Receiver Skew	t <sub>RS</sub>	t <sub>PHL</sub> - t <sub>PLH</sub>  , Figure 1		50		ns
Receiver Output Enable Time	t <sub>ROE</sub>			200		ns
Receiver Output Disable Time	t <sub>ROD</sub>			200		ns
Receiver Positive or Negative Threshold to $\overline{\text{INVALID}}$ High	t <sub>IN VH</sub>			250		ns
Receiver Positive or Negative Threshold to $\overline{\text{INVALID}}$ Low	t <sub>IN VL</sub>			30		µs

**Note 1:** Specifications are 100% tested at T<sub>A</sub> = +25°C. Limits over temperature are guaranteed by design.

## Typical Operating Characteristics

(V<sub>CC</sub> = +5V, T<sub>A</sub> = +25°C, unless otherwise noted.)

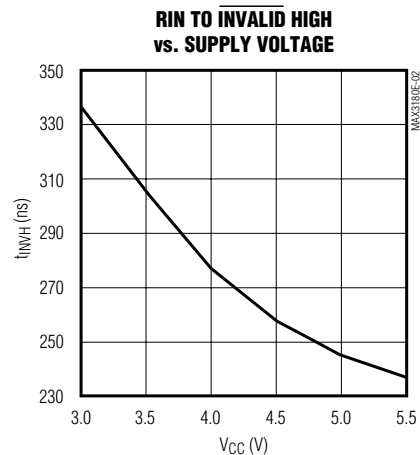
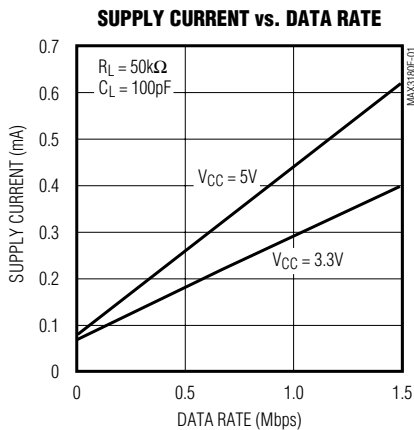

# ±15kV ESD-Protected, 0.5µA, +3V to +5.5V, 1.5Mbps RS-232 Receivers in SOT23-5

## Typical Operating Characteristics (continued)

(V<sub>CC</sub> = +5V, T<sub>A</sub> = +25°C, unless otherwise noted.)

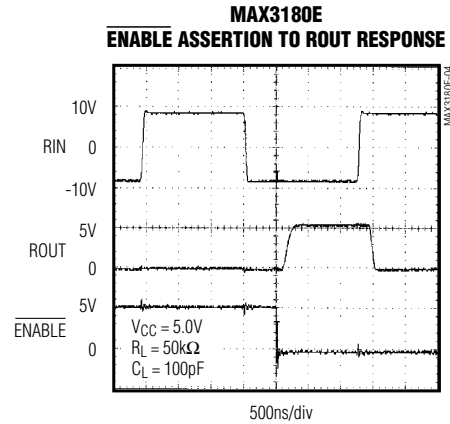
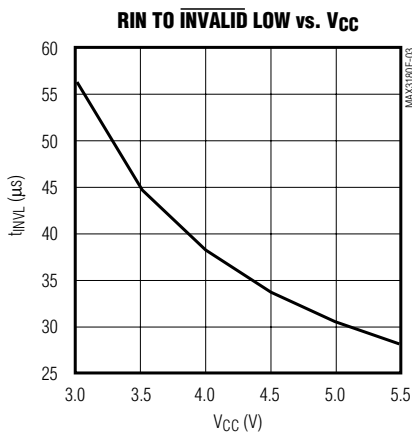

## Pin Description

PIN	NAME				FUNCTION
	MAX3180E	MAX3181E	MAX3182E	MAX3183E	
1	$\overline{\text{EN}}$	–	$\overline{\text{EN}}$	–	Receiver Output Enable
	–	$\overline{\text{INVALID}}$	–	$\overline{\text{INVALID}}$	Output of the Valid Input Detector
2	GND	GND	GND	GND	Ground
3	ROUT	ROUT	–	–	Inverting Receiver Output
	–	–	ROUT	ROUT	Noninverting Receiver Output
4	RIN	RIN	RIN	RIN	Receiver Input
5	V <sub>CC</sub>	V <sub>CC</sub>	V <sub>CC</sub>	V <sub>CC</sub>	Supply Voltage

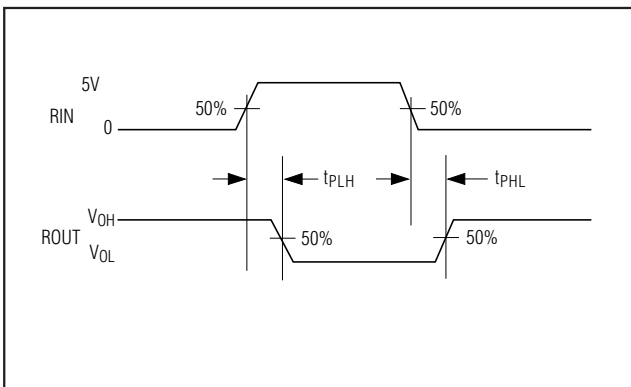

Figure 1. Receiver Propagation-Delay Timing

## Detailed Description

The MAX3180E–MAX3183E are EIA/TIA-232 and V.28/V.24 communications receivers that convert RS-232 signals to CMOS logic levels. They operate on a +3V to +5.5V supply, have 1.5Mbps data rate capability, and feature enhanced electrostatic discharge (ESD) protection (see *ESD Protection*). All of these devices achieve a typical supply current of 0.5µA. The MAX3180E/MAX3182E have a receiver enable control ( $\overline{\text{EN}}$ ). The MAX3181E/MAX3183E contain a signal invalid output ( $\overline{\text{INVALID}}$ ). The MAX3180E/MAX3181E invert the ROUT signal relative to RIN (standard RS-232). The MAX3182E/MAX3183E outputs are not inverted. The devices come in tiny SOT23-5 packages.

# ±15kV ESD-Protected, 0.5µA, +3V to +5.5V, 1.5Mbps RS-232 Receivers in SOT23-5

MAX3180E-MAX3183E

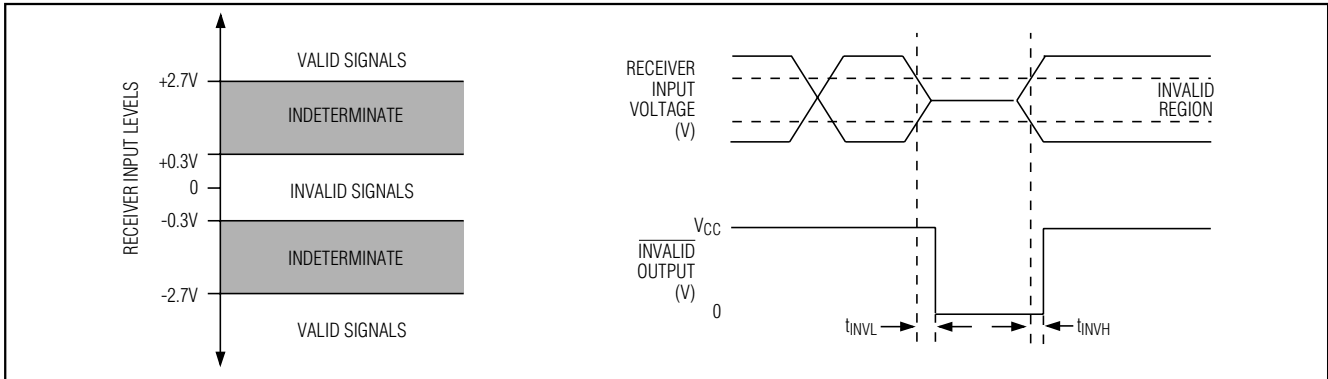

Figure 2. Input Levels and  $\overline{\text{INVALID}}$  Timing

### Signal Invalid Detector

If no valid signal levels appear on RIN for 30µs (typ),  $\overline{\text{INVALID}}$  goes low. This event typically occurs if the RS-232 cable is disconnected, or if the connected peripheral transmitter is turned off.  $\overline{\text{INVALID}}$  goes high when a valid level is applied to the RS-232 receiver input. Figure 2 shows the input levels and timing diagram for  $\overline{\text{INVALID}}$  operation.

### Enable Input

The MAX3180E/MAX3182E feature an enable input (EN). Drive  $\overline{\text{EN}}$  high to force ROUT into a high-impedance state. In this state, the devices ignore incoming RS-232 signals. Pull EN low for normal operation.

### ESD Protection

As with all Maxim devices, ESD protection structures are incorporated on all pins to protect against ESD encountered during handling and assembly. The receiver inputs of the MAX3180E–MAX3183E have extra protection against static electricity. Maxim’s engineers have developed state-of-the-art structures enabling these pins to withstand ESD up to ±15kV without damage or latchup. The receiver inputs of the MAX3180E–MAX3183E are characterized for protection to the following limits:

- ±15kV using the Human Body Model
- ±8kV using the Contact Discharge method specified in IEC 1000-4-2
- ±15kV using the Air-Gap Discharge method specified in IEC 1000-4-2

### Human Body Model

Figure 3 shows the Human Body Model, and Figure 4 shows the current waveform it generates when discharged into a low impedance. This model consists of

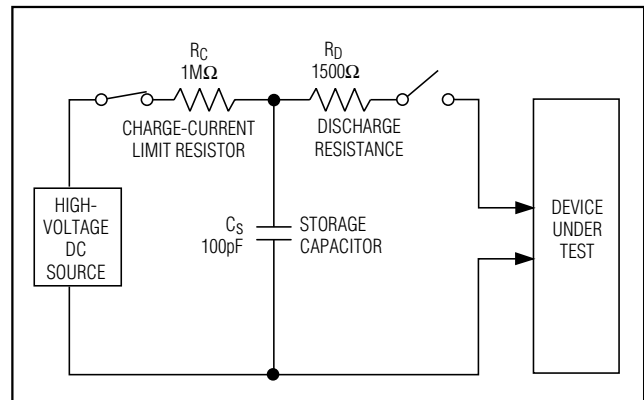

Figure 3. Human Body ESD Test Model

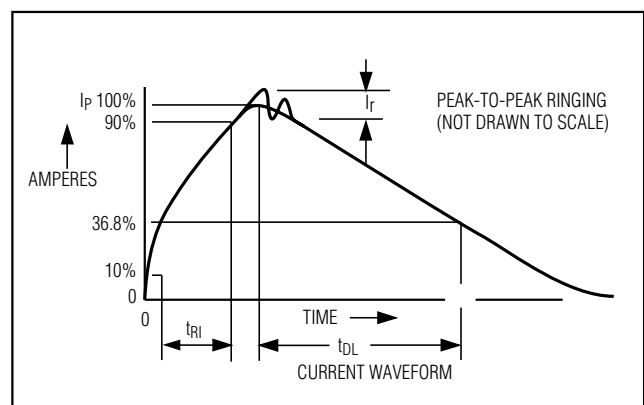

Figure 4. Human Body Model Current Waveform

a 100pF capacitor charged to the ESD voltage of interest, and then discharged into the test device through a 1.5kΩ resistor.

# **±15kV ESD-Protected, 0.5µA, +3V to +5.5V, 1.5Mbps RS-232 Receivers in SOT23-5**

## **IEC 1000-4-2**

The IEC 1000-4-2 standard covers ESD testing and performance of finished equipment; it does not specifically refer to ICs. The MAX3180E-MAX3183E enable the design of equipment that meets the highest level (Level 4) of IEC 1000-4-2 without the need for additional ESD-protection components.

The major difference between tests done using the Human Body Model and IEC 1000-4-2 is higher peak current in IEC 1000-4-2. Because series resistance is lower in the IEC 1000-4-2 model, the ESD withstand voltage measured to this standard is generally lower than that measured using the Human Body. Figure 5 shows the IEC 1000-4-2 model, and Figure 6 shows the

current waveform for the ±8kV IEC 1000-4-2 Level 4 ESD Contact Discharge test.

The Air-Gap test involves approaching the device with a charged probe. The Contact Discharge method connects the probe to the device before the probe is energized.

## **Power-Supply Decoupling**

In most circumstances, a 0.1µF V<sub>CC</sub> bypass capacitor is adequate. Connect the bypass capacitor as close to the IC as possible.

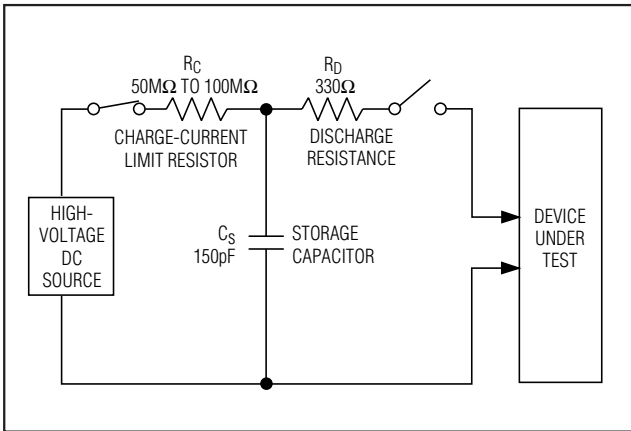

Figure 5. IEC 1000-4-2 ESD Test Model

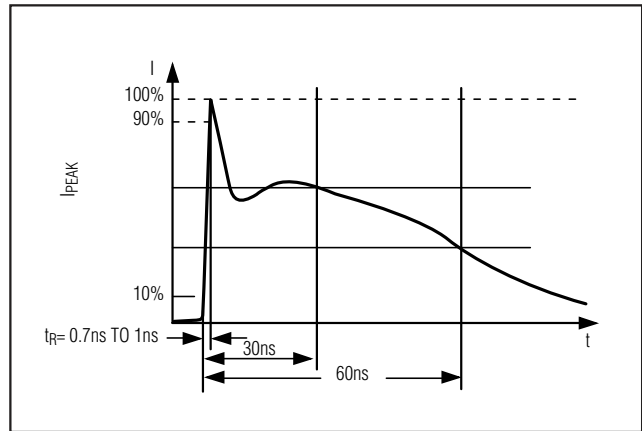
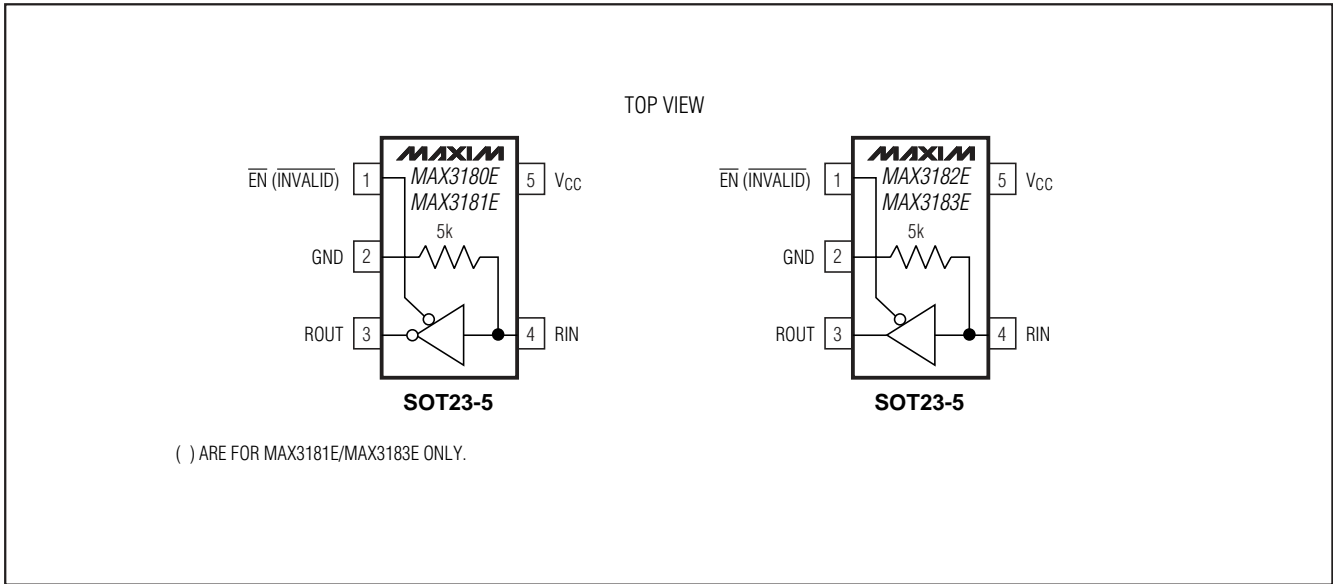

Figure 6. IEC 1000-4-2 ESD Generator Current Waveform

# ±15kV ESD-Protected, 0.5µA, +3V to +5.5V, 1.5Mbps RS-232 Receivers in SOT23-5

## Pin Configurations/Functional Diagrams

**MAX3180E-MAX3183E**



## Chip Information

TRANSISTOR COUNT: 41

**±15kV ESD-Protected, 0.5µA, +3V to +5.5V,  
1.5Mbps RS-232 Receivers in SOT23-5**

**Package Information**

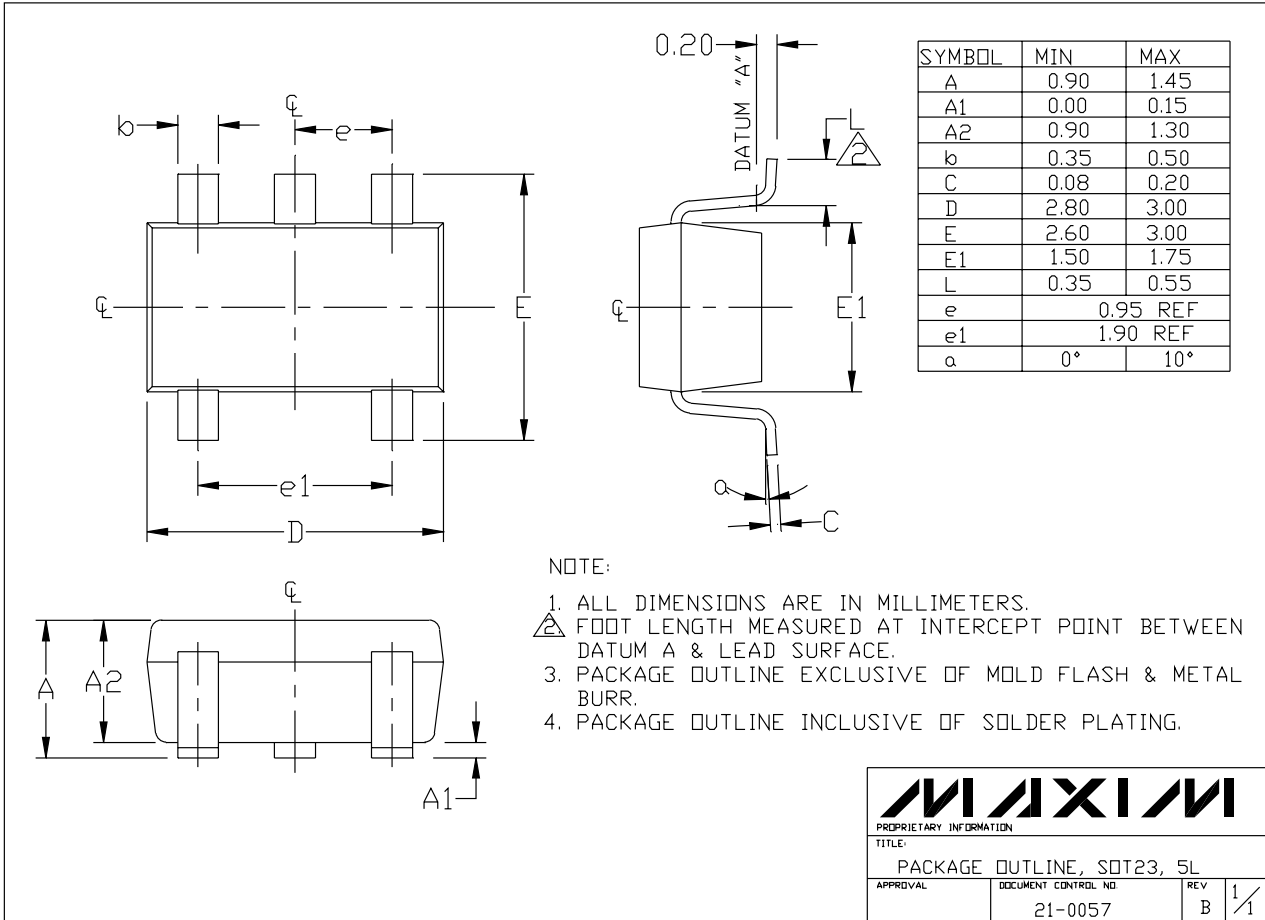

SOT23-5

Maxim cannot assume responsibility for use of any circuitry other than circuitry entirely embodied in a Maxim product. No circuit patent licenses are implied. Maxim reserves the right to change the circuitry and specifications without notice at any time.

8 **Maxim Integrated Products, 120 San Gabriel Drive, Sunnyvale, CA 94086 408-737-7600**