

ⓑ

NOTES:

1. RoHS COMPLIANT
2. FOR WAVE SOLDERING (SOLDER BATH TEMPERATURE 260°C FOR 5 SEC. AND SOLDER PREHEAT 100° FOR 30 SEC.)
3. METAL SHELLS: STEEL; min. 315µm TIN over 40-80µm NICKEL
4. INSULATORS: HIGH TEMPERATURE PLASTIC UL 94 V-0; BLACK
5. CONTACTS: COPPER ALLOY; PLATING (SEE PART NO.):
 - PLEASE ADD A for GOLD FLASH over NICKEL (PREFERRED TYPE)
 - PLEASE ADD B for 20µm HARD GOLD over min. 50µm NICKEL
 - PLEASE ADD C for 30µm HARD GOLD over min. 50µm NICKEL
6. METAL BRACKETS: STEEL; min. 320µm TIN over 80µm NICKEL
7. THREADED INSERTS: COPPER ALLOY; min. 200µm TIN over 80µm NICKEL
8. PCB-SNAPS: COPPER ALLOY; min. 200µm TIN over 80µm NICKEL
PCB-HOLE: $\varnothing 3.1 \pm 0.1$ mm; PCB THICKNESS 1.6mm
9. FIXING-PLATE: PBT GF UL 94 V-0; BLACK
10. SEALING COMPOUND: PUR; BLUE
11. CAPACITANCE: 830pF $\pm 20\%$
12. DIELECTRIC WITHSTANDING VOLTAGE: 424 VDC
13. PCB HOLE DRILLINGS ON SHEET 2
14. MAXIMUM TORQUE VALUE FOR THREAD: 6 in.LB
15. CONNECTOR IS PART MARKED: 241□27340X CONEC ABC (see note 5)

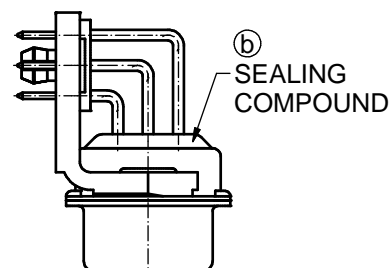
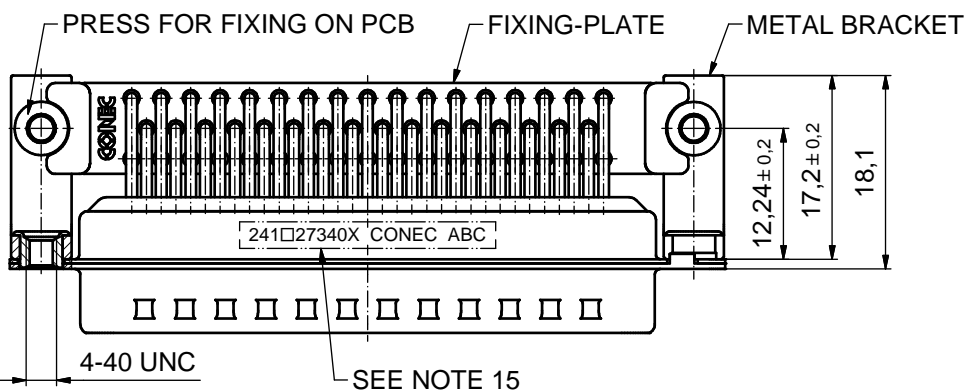
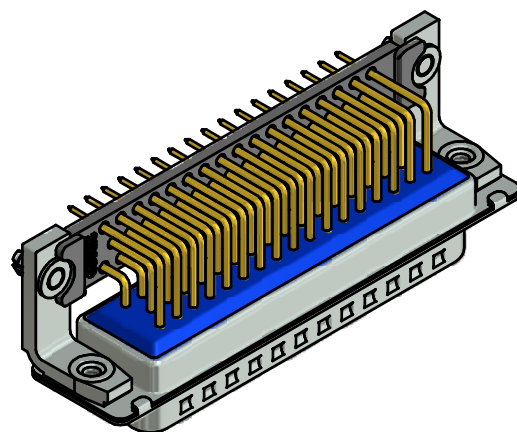
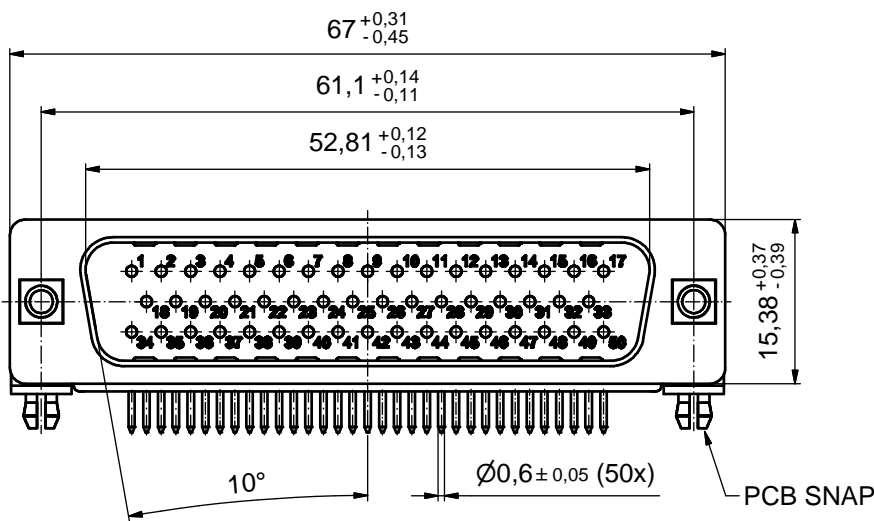
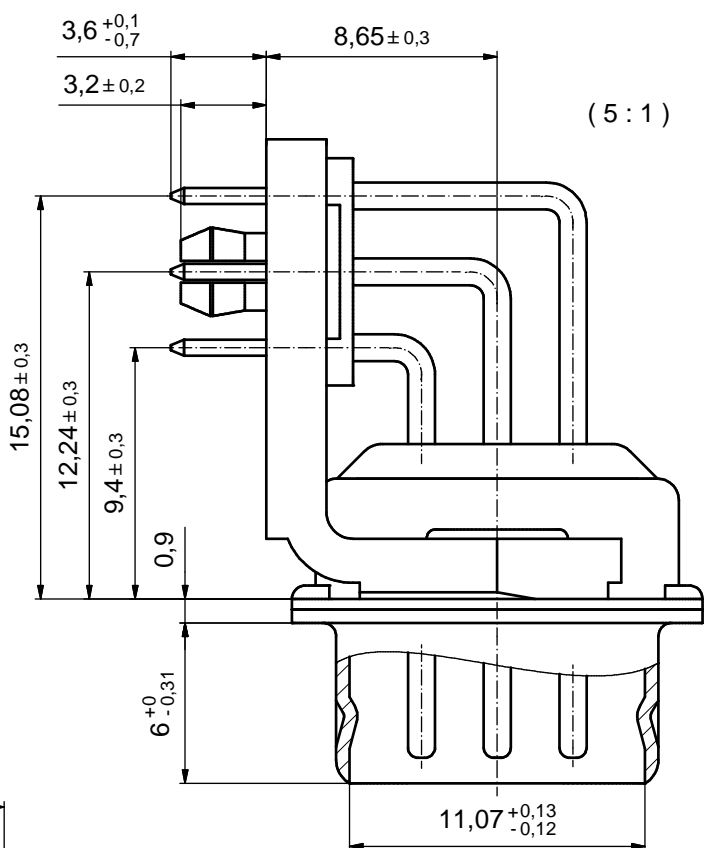

RoHS compliant

THIS DRAWING MAY NOT BE COPIED OR REPRODUCED IN ANY WAY, AND MAY NOT BE PASSED ON TO A THIRD PARTY WITHOUT WRITTEN PERMISSION. OWNERSHIP AND COPYRIGHT OF CONEC GmbH DO NOT ALTER CAD DRAWING BY HAND	tolerance		dim. in mm		scale:	2:1 (5:1)	
					material:	SEE NOTES	
	date	name		title:			
	drawn	11.11.05	Lehmenkühler		D-SUB C-FILTER MALE 90°		
	appd.	11.11.05	Mickenbecker		50pos. SOLDER PIN ANGLED 0.370inch		
norm	DIN 41652		threaded insert, metal bracket, fixing-plate, snap				
d-old			dwg no:		DIN-A3		
2 x b	Ä6131	18.05.2016	Lehm.	24K1A720		sh: 1/2	
a	Original			part no:			
rev.	description	date	name	241□27340X (see note 5)			



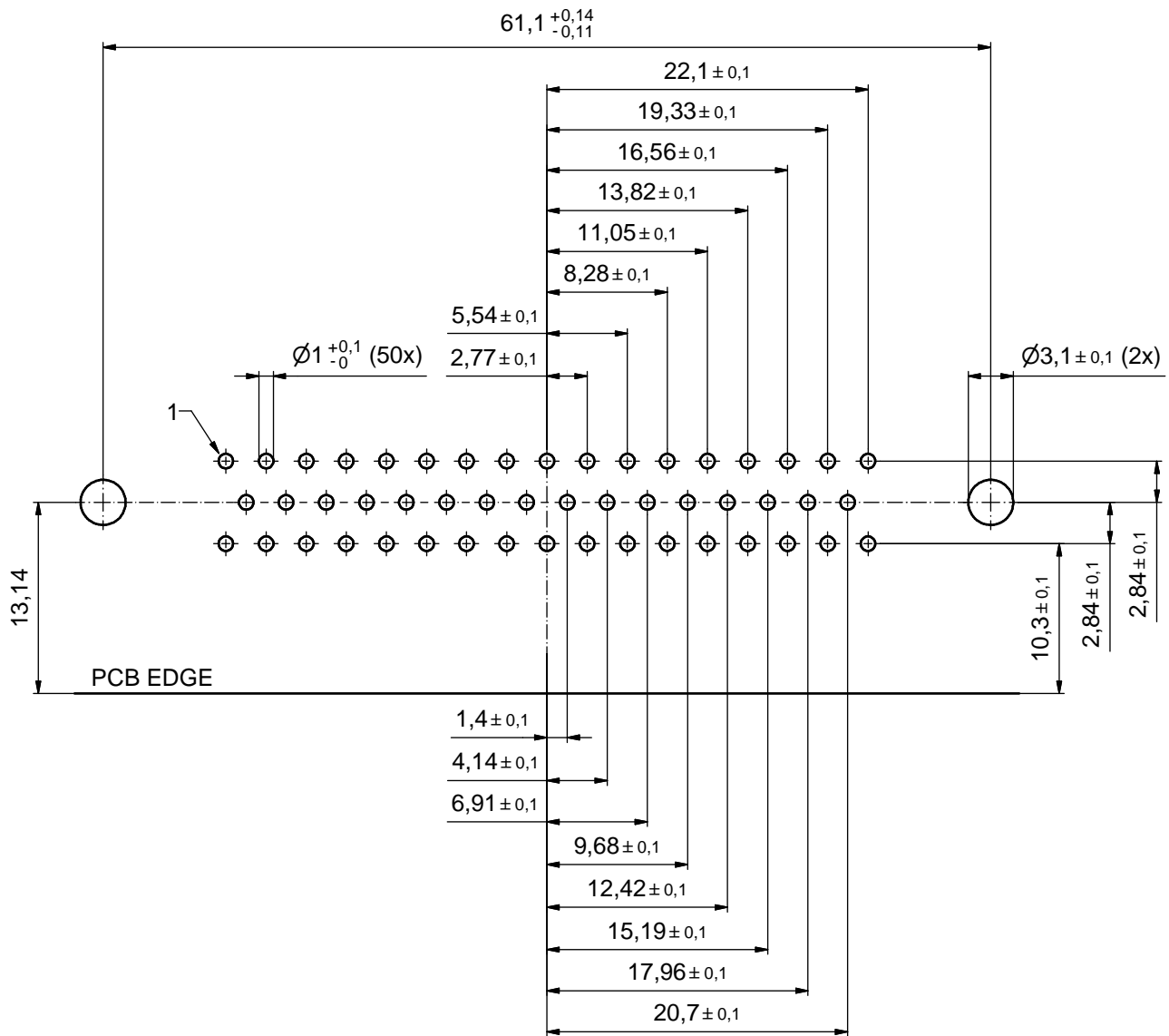

PCB HOLE DRILLINGS
(PCB TOP SIDE)

THIS DRAWING MAY NOT BE COPIED OR REPRODUCED IN ANY WAY, AND MAY NOT BE PASSED ON TO A THIRD PARTY WITHOUT WRITTEN PERMISSION. OWNERSHIP AND COPYRIGHT OF CONEC GmbH DO NOT ALTER CAD DRAWING BY HAND					tolerance		dim. in mm	scale: 3:1		
								material: SEE SHEET 1		
					date	name		title:		
					drawn	11.11.05	Lehmenkühler		PCB HOLE DRILLINGS D-SUB C-FILTER MALE 90° 50pos. 0.370inch threaded insert, metal bracket, fixing-plate, snap	
					appd.	11.11.05	Mickenbecker			
					norm					
					d-old					
	a	Original					dwg no: 24K1A720		DIN-A3	
	rev.	description	date	name			part no: SEE SHEET 1		sh:	