

LOC	DIST	REVISIONS			
P	LTR	DESCRIPTION	DATE	DWN	APVD
GP	00	A	NEW RELEASE	13SEP107	RG PD
		B	REV PER ECO-11-020831	12SEP2011	RG MS

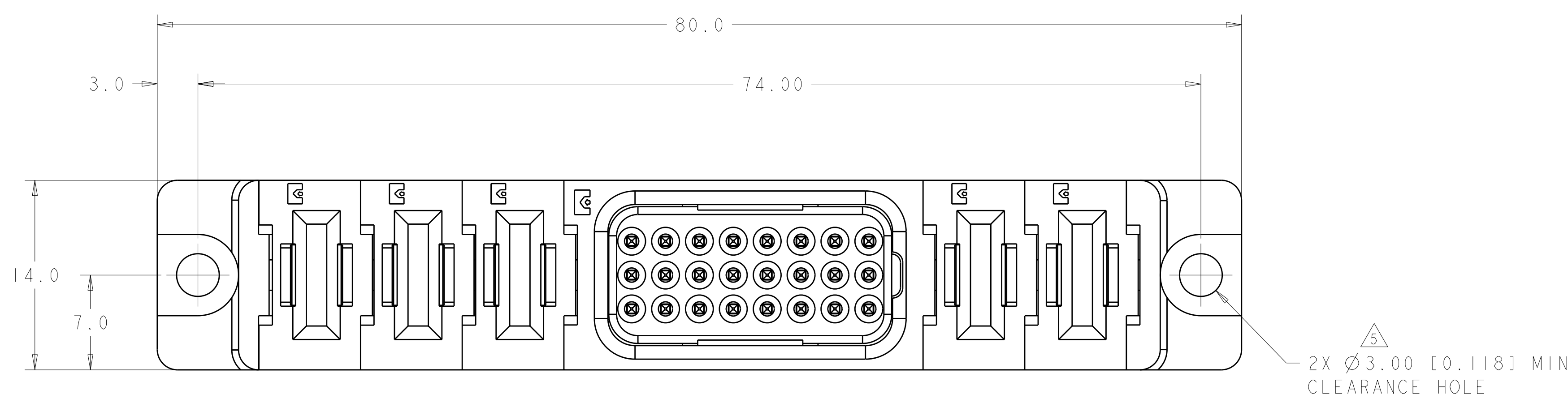

- PART NUMBER CHANGES AND OR DESIGN CHANGES AFFECTING ITEM INTERCHANGEABILITY REQUIRE PRIOR TYCO ELECTRONICS APPROVAL AND AUTHORIZATION BY REVISION TO THIS DRAWING.
 - MATERIAL:
 - INSULATORS - THERMOPLASTIC, GLASS REINFORCED, COLOR: BLACK, UL94V-0 FLAMMABILITY RATED.
 - POWER CONTACTS - PHOSPHOR BRONZE ALLOY, COPPER ALLOY
 - CROWN BAND-BERYLLIUM COPPER ALLOY
 - SIGNAL CONTACTS-BERYLLIUM COPPER ALLOY
 - FINISH:
 - CONTACTS - GOLD PLATE .76µm MIN. THK., OVER NICKEL 1.27µm MIN. THK
 - SOLDER TAILS- TIN 3.05 MIN. THK. OVER NICKEL 1.27µm MIN THK.
- △ ITEMS PROVIDED TO THIS SPECIFICATION TO BE PERMANENTLY IDENTIFIED PER THE FOLLOWING IDENTIFIER LABEL
- YEAR WEEK
- TYCO ELECTRONICS P/N DATE CODE (e.g. 0106)
- XXXXXXX-X XXXX
- △ MOUNTING FLANGES ACCEPT #6 SCREWS. (USER SUPPLIED)

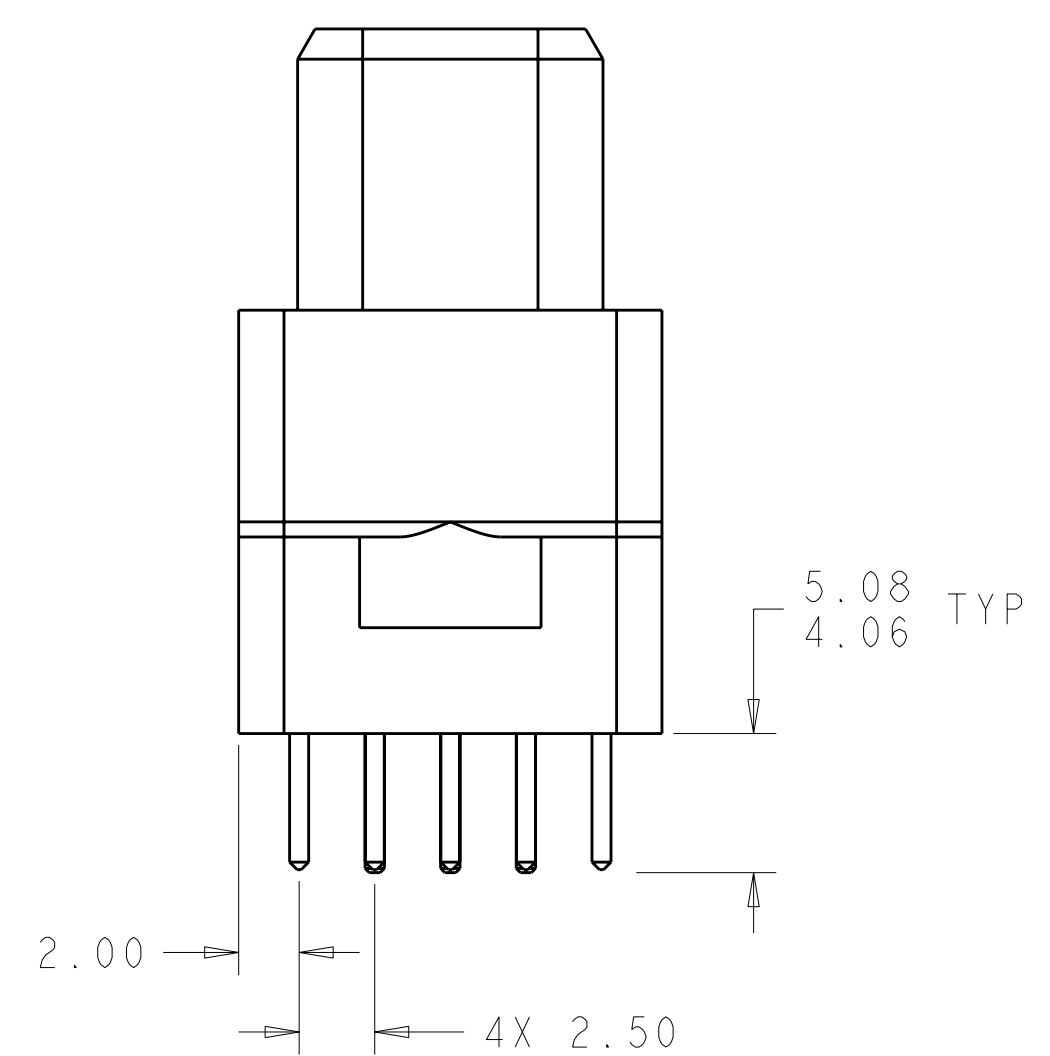
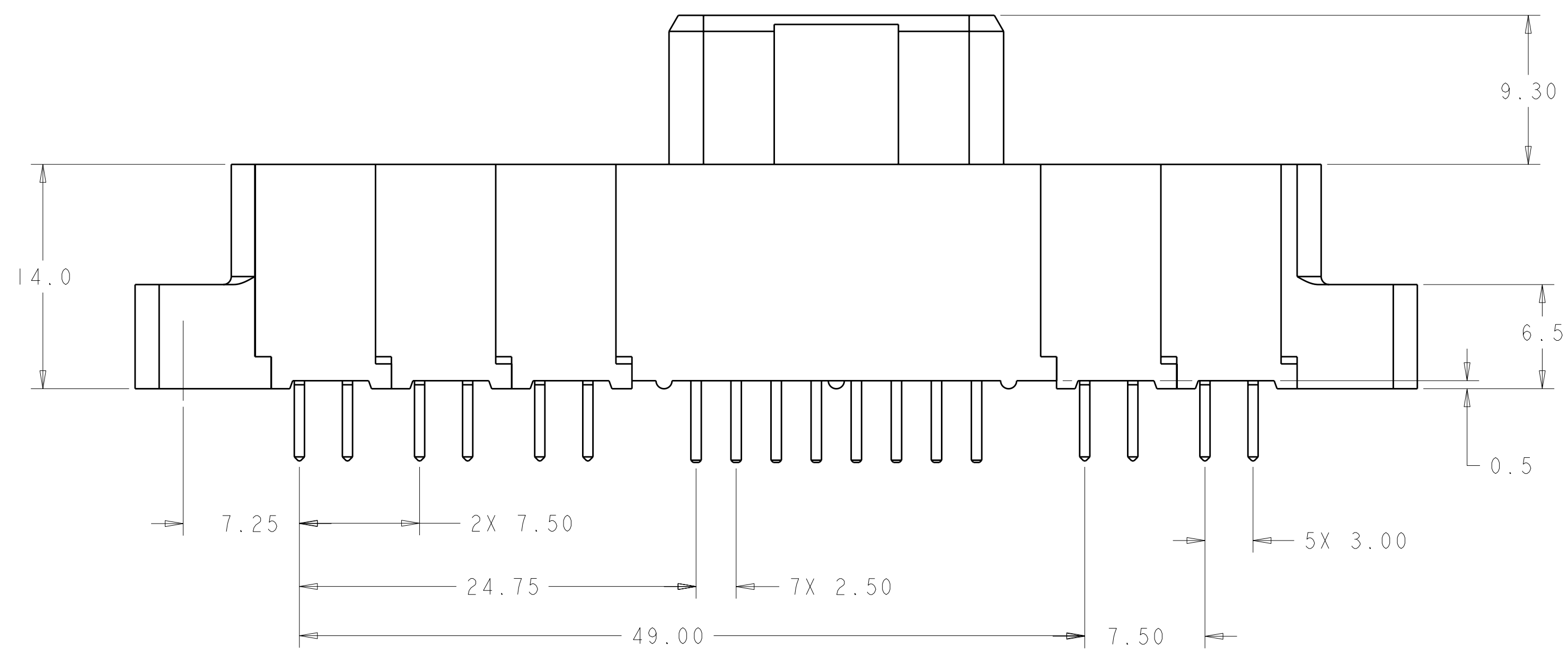

ELCON FLATPAQ

DIMENSIONS:		TOLERANCES UNLESS OTHERWISE SPECIFIED:		DWN: R. GRZYBOWSKI 13SEP107	
mm	0 PLC ±	1 PLC ±0.3 (f. 0.12)	2 PLC ±0.15 (f. 0.06)	CHK: P. DAMATO 13SEP107	APVD: S. FLICKINGER 13SEP107
	3 PLC ±	4 PLC ±	ANGLES ±	NAME: R. GRZYBOWSKI	
MATERIAL:	FINISH:	WEIGHT:	CUSTOMER DRAWING	Tyco Electronics Harrisburg, PA 17105-3608	
AS SHOWN			6646273-1		
DESCRIPTION			PART NUMBER		
SOCKET CONNECTOR STRAIGHT, SOLDER TAILS FLATPAQ					
SIZE:	CAGE CODE:	DRAWING NO:	RESTRICTED TO:	A 00779 C=6646273	
SCALE:	3:1	SHEET:	1 OF 3	REV:	B

LOC	DIST	REVISIONS			
P	LTR	DESCRIPTION	DATE	DWN	APVD
GP	00	SEE SHEET 1	-	-	-

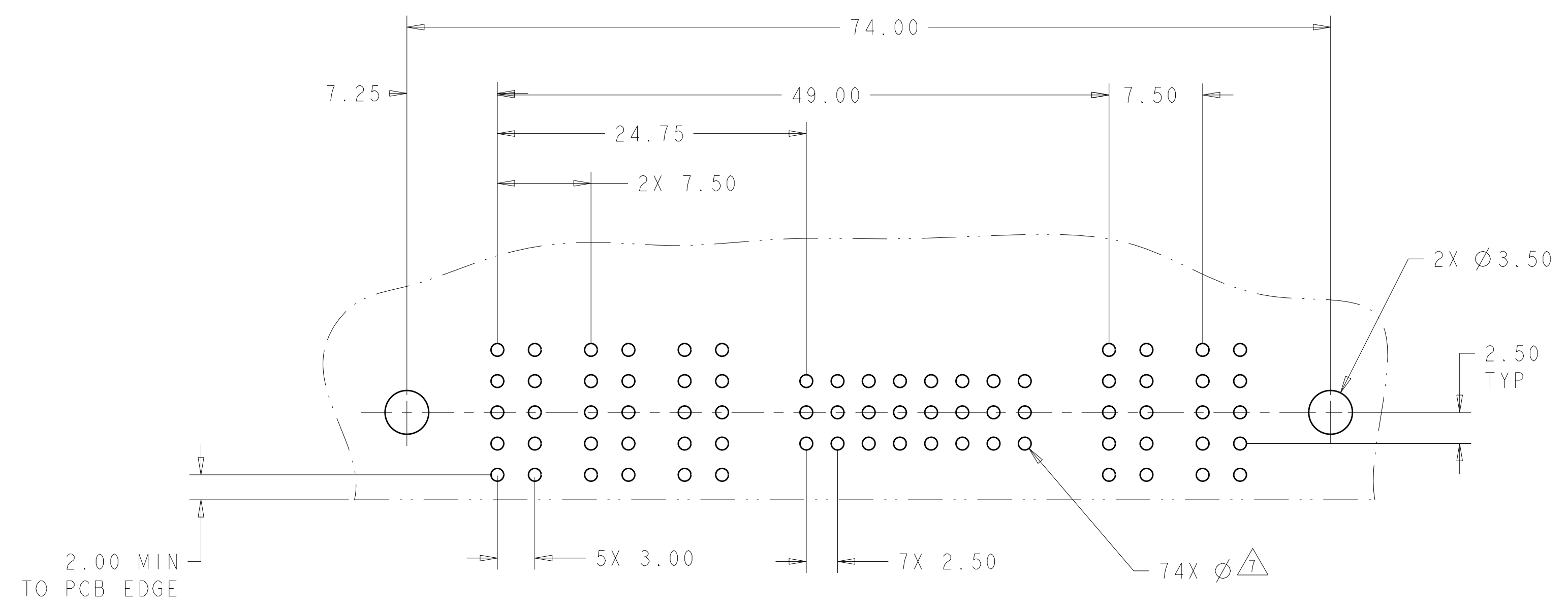

PRINTED CIRCUIT LAYOUT
 COMPONENT SIDE

CONNECTOR	CATALOG MODULE #	QTY	SIZE NO.	CONTACT QTY	MATING PIN	MAX. CURRENT (PER CONTACT)	CONTACT SPACING	VOLTAGE RATING
SOCKET	FP100	5	8	5	1.25 X 7.00 [.049 X .276]	35 amps	7.50 [0.295]	250 VOLTS
	FP301	1	22	24	.64 [.025] SQ.	3 amps	2.50 [.0984]	125 VOLTS
	FP500	1	MOUNTING FLANGE, LEFT					
	FP501	1	MOUNTING FLANGE, RIGHT					

ELCON FLATPAQ

DIMENSIONS: mm 		TOLERANCES UNLESS OTHERWISE SPECIFIED: 9 PLC ±.3 [.012] 3 PLC ±0.15 [1.006] 4 PLC ±. ANGLES ±.3		DWN R. GRZYBOWSKI 13SEP107 CHK P. DAMATO 13SEP107 APVD S. FLICKINGER 13SEP107		Tyco Electronics Harrisburg, PA 17105-3608	
MATERIAL: - FINISH: -		WEIGHT: -		NAME: SOCKET CONNECTOR STRAIGHT, SOLDER TAILS FLATPAQ SIZE: A 00779 C=6646273 SCALE: 3:1 SHEET 2 OF 3 REV B		RESTRICTED TO: -	
CUSTOMER DRAWING				SCALE 3:1 SHEET 2 OF 3 REV B			

