



Doc.No.: AFY480272A0-4.3N6NTM

REV : A0

PAGE : 1/18

EFFECTIVE DATE : 2013-01-29

SPECIFICATION OF LCD MODULE

MODULE NO: AFY480272A0-4.3N6NTM

Customer Approval:

Accept

Reject

FUTURE FOCUS	SIGNATURE	DATE
PREPARED BY		
CHECKED BY		
APPROVED BY		



Doc.No.: AFY480272A0-4.3N6NTM

REV : A0

PAGE : 2/18

EFFECTIVE DATE : 2013-01-29

Sample Version	Doc. Version	DATE	DESCRIPTION	CHECKED BY
0001	A0	2013-01-29	First Release	

CONTENTS

List	Description	Page No.
	NUMBER SYSTEM INTRODUCTION	4
1	GENERAL SPECIFICATIONS	4
2	BLOCK DIAGRAM	5
3	DIMENSIONAL OUTLINE	6
4	PIN DESCRIPTION	7
5	ELECTRICAL CHARACTERISTICS	8
6	INPUT SIGNAL TIMING	12
7	OPTICAL CHARACTERISTICS	15
8	RELIABILITY	17
9	SPECIFICATION OF QUALITY ASSURANCE	17
10	GENERAL PRECAUTION	17
11	LIMITED WARRANTY	17
12	PACKAGE	18

NUMBER SYSTEM INTRODUCTION:

AFY480272A0-4.3N6NTM-R:

AF: Orient Display TFT;

Y: JAZZ TFT;

480272: Length * width pixel;

A0: Product Version;

4.3: Diagonal Dimension;

N: LCD Mode (N: TN; I: IPS; V: VA)

6: Viewing Direction (6-> 6:00; 12->12:00; Unavailable for IPS and VA);

N: Temperature Range (N: Normal; W: Wide);

T: Polarizer (T:Transmissive; F:Transflective);

M: Luminance (N: Normal <300 nit; M: Middle >=300 & <600 nit;

H: High >=600 nit);

R: TP Option (R: Resistive TP; C: Capacitive TP; N: Without TP);

1. GENERAL SPECIFICATIONS

ITEM	SPECIFICATION	UNIT
OUTLINE DIMENSIONS	105.5 (W) X67.2 (H) X3.0 (D)	mm
DISPLAY SIZE	4.3	inch
DOT PITCH	0.198mmX0.198mm	mm
NUMBER OF DOTS	480* (RGB) *272	-
DRIVER IC	OTA5180A	-
LCD TYPE	TFT(16.7M) TRANSMISSIVE	-
INTERFACE	RGB 24BITS	
BACKLIGHT TYPE	LED White	-
VIEWING DIRECTION	6 O'clock	-
GRAY SCALE INVERSION DIRECTION	6 O'clock	

*See attached drawing for details.

2. BLOCK DIAGRAM

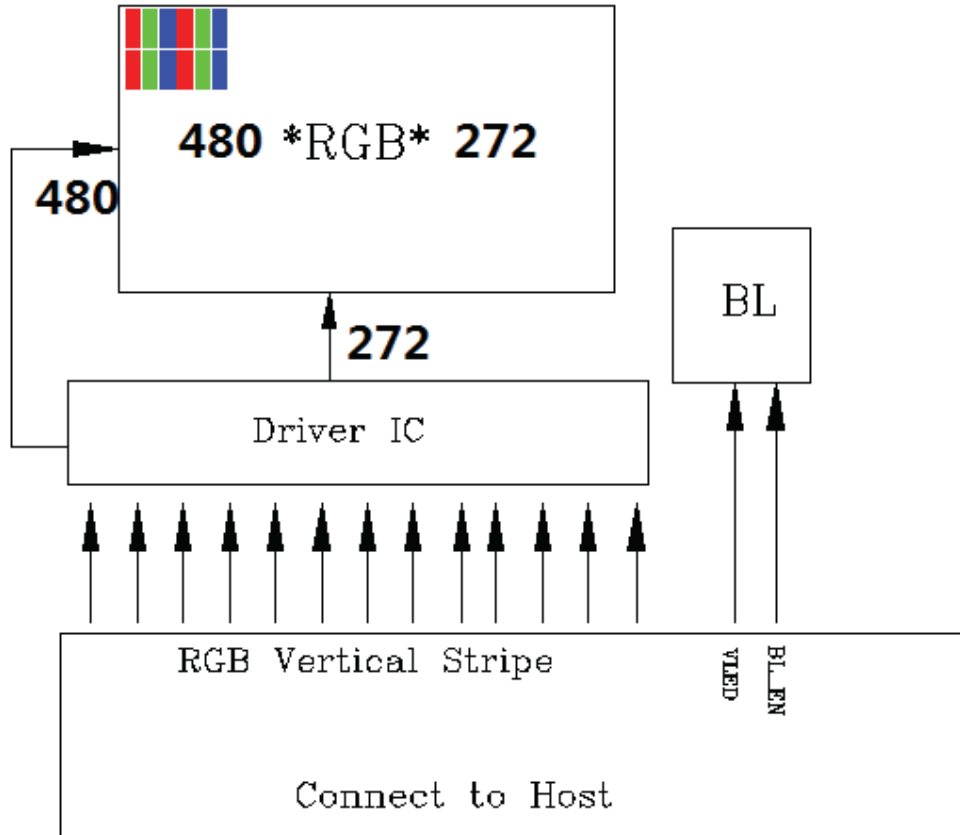

3. DIMENSIONAL OUTLINE

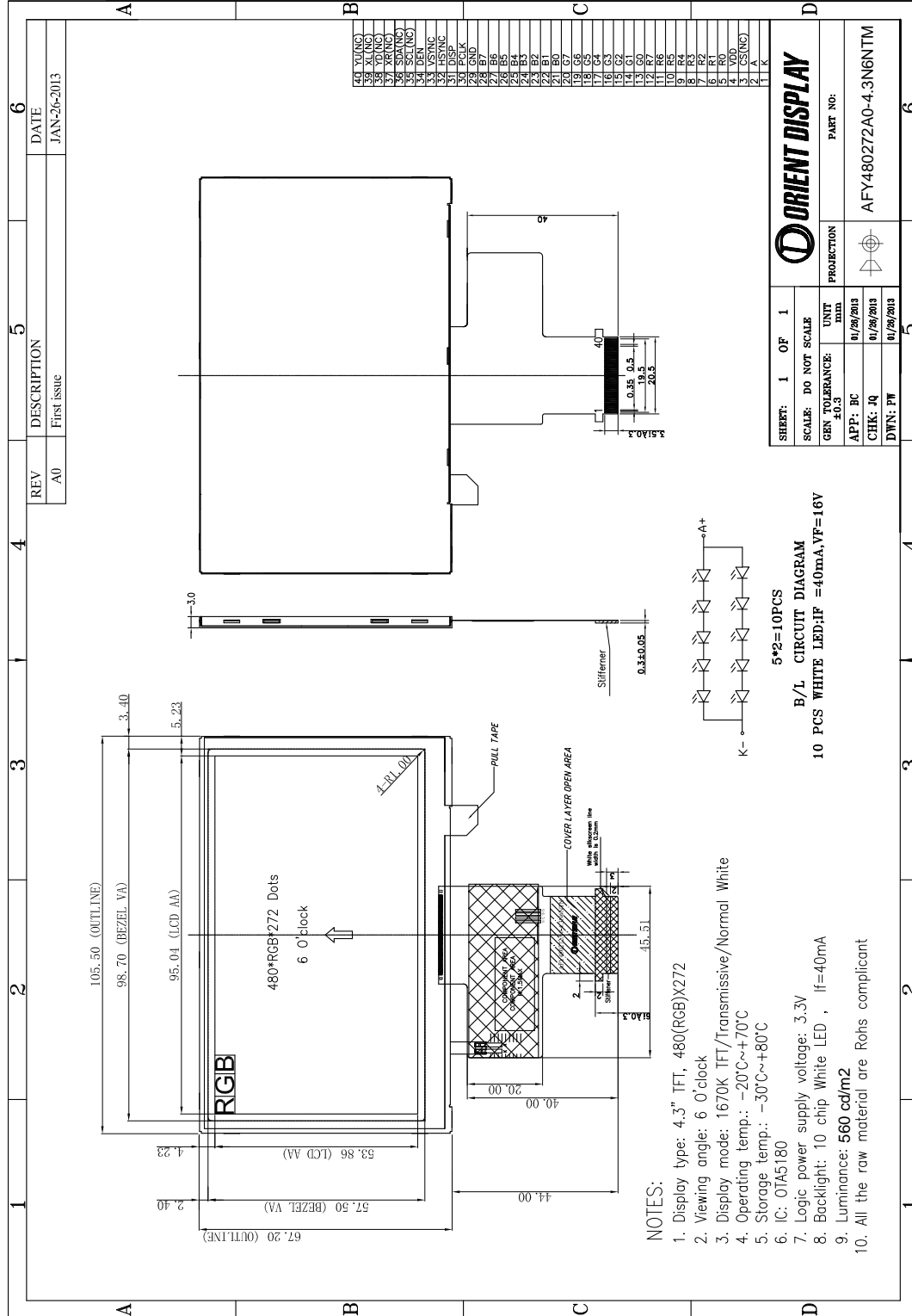

4. PIN DESCRIPTION

NO.	PIN NAME	Type	Description
1	LED-	P	Power supply for LED (Cathode)
2	LED+	P	Power supply for LED (Anode)
3	CS (NC)	-	No connection
4	VDD	P	Power voltage
5	R0	I	RED data signal(LSB)
6	R1	I	RED data signal
7	R2	I	RED data signal
8	R3	I	RED data signal
9	R4	I	RED data signal
10	R5	I	RED data signal
11	R6	I	RED data signal
12	R7	I	RED data signal(MSB)
13	G0	I	GREEN data signal(LSB)
14	G1	I	GREEN data signal
15	G2	I	GREEN data signal
16	G3	I	GREEN data signal
17	G4	I	GREEN data signal
18	G5	I	GREEN data signal
19	G6	I	GREEN data signal
20	G7	I	GREEN data signal(MSB)
21	B0	I	BLUE data signal(LSB)
22	B1	I	BLUE data signal
23	B2	I	BLUE data signal
24	B3	I	BLUE data signal
25	B4	I	BLUE data signal
26	B5	I	BLUE data signal
27	B6	I	BLUE data signal
28	B7	I	BLUE data signal(MSB)
29	GND	P	Ground(0V)
30	DOTCLK	I	Pixel clock signal
31	DISP	I	Display on/ off
32	HSYNC	I	Horizontal synchronizing signal
33	VSYNC	I	Vertical synchronizing signal
34	DE	I	Data enable
35	SCL (NC)	-	No connection
36	SDA (NC)	-	No connection
37	XR (NC)	-	No connection
38	YD (NC)	-	No connection
39	XL (NC)	-	No connection
40	YU (NC)	-	No connection

Note: I: input, O: output, P: Power

5. ELECTRICAL CHARACTERISTICS

5.1 Absolute Maximum Ratings

Item	Symbol	Values		Unit	Remark
		Min	Max		
Power Supply for Pump	VDD	-0.3	4.5	V	

Note: Stresses beyond those given in the Absolute Maximum Rating table may cause operational errors or damage to the device. For normal operational conditions see AC/DC Electrical Characteristics

5.2 DC Characteristics

5.2.1 Operating Conditions

Item	Symbol	Values			Unit	Conditions
		Min	Typ	Max		
Charge Pump Supply Voltage	PVDD	3	3.3	3.6	V	PWR_SEL=H
Digital Supply Voltage	VDD	3	3.3	3.6	V	PWR_SEL=H
Digital Interface Supply	VDDIO	1.65	1.8	VDD	V	
Digital Input Voltage	Di	0	-	VDDIO	V	
OTP Supply Voltage	V_OTP	7.4	7.5	7.6	V	
VCOM AC Voltage	VCOMH-VCOML	3.46	-	6.2	V	

5.2.2 DC Characteristics for Digital Circuit

Item	Symbol	Values			Unit	Conditions
		Min	Typ	Max		
Low Level Input Voltage	Vil	GND	-	0.3xVDDIO	v	
High Level Input Voltage	Vih	0.7xVDDIO	-	VDDIO	uA	
High Level Output Voltage	Voh	VDDIO-0.4	-	VDDIO	ohm	
Low Level Output Voltage	Vol	GND	-	GND+0.4	uA	
Input Leakage Current	Iil			±1.0		
Pull High/Low Resistor	Rp	-	100K	-	ohm	

5.2.3 DC Characteristics for Analog Circuit

VDDIO=1.8V, VDD = 3.3V, AVDD = 6V, AGND = 0V, TA = -20°C to 80°C

Item	Symbol	Values			Unit	Conditions
		Min	Typ	Max		
Analog Supply Voltage	VDD2		5		V	
Positive High-voltage power	VGH	9	15	16	V	No Load. By VGH_SEL setting.
Negative High-voltage power	VGL	-11	-10	-7	V	No Load. By VGL_SEL setting.
VCOMH Output Level	VCOMH	3.26		5.8	V	By VCOMH setting.
VCOML Output Level	VCOML	-2		-0.2	V	By VCOML setting
Output Voltage Deviation	Vod	-	±20	±35	mV	VO = 0.15V ~ 0.5V, 3.45V~3.8V
		-	±15	±20		VO = 0.5V ~ 3.45V
Output Dynamic Range	Vdr	0.2	-	5.3		MVA Mode
		0.15		4.8		TN Mode
VCOM Low Level Output Current	IOLFRP		-10		mA	VCOM AC output = 0.5V
VCOM High Level Output Current	IOHFRP		-10		mA	VCOM AC output = 5.7V
Analog Standby Current	Ilast	-	-	20	uA	
Analog Operation Current	IDD	-	5.0	-	mA	Without panel loading

5.3 DC BackLight Unit

Item	Symbol	Min	Typ	Max	Unit	Remark
Average luminous Intensity	Iv		560		cd/m2	IF=40mA
Chromaticity Coordinates	X	0.234	0.284	0.334		IF=40mA
	Y	0.273	0.323	0.373		IF=40mA
Forward Voltage	VF		16.0	17.0	V	IF=40mA
Reverse Current	IR			50	µA	VR=20V, 1LED
Luminous Tolerance	IV-M	80			%	(MIN/MAX)×100
Power Dissipation	Pd		640		mW	
Peak Forward Current	I _{fp}		100		mA	
Reverse Voltage	VR		5		V	

5.3.1 Internal Circuit Diagram

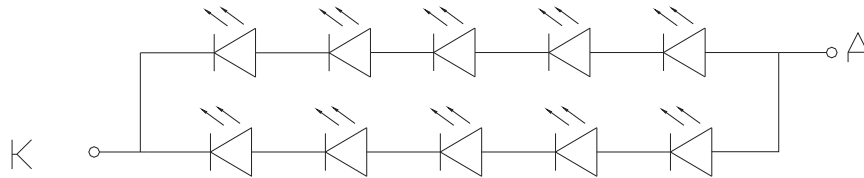

B/L CIRCUIT DIAGRAM

10 PCS WHITE LED; $I_F = 40\text{mA}$, $V_F = 16\text{V}$

5.4 POWER SEQUENCE

Power On Sequence

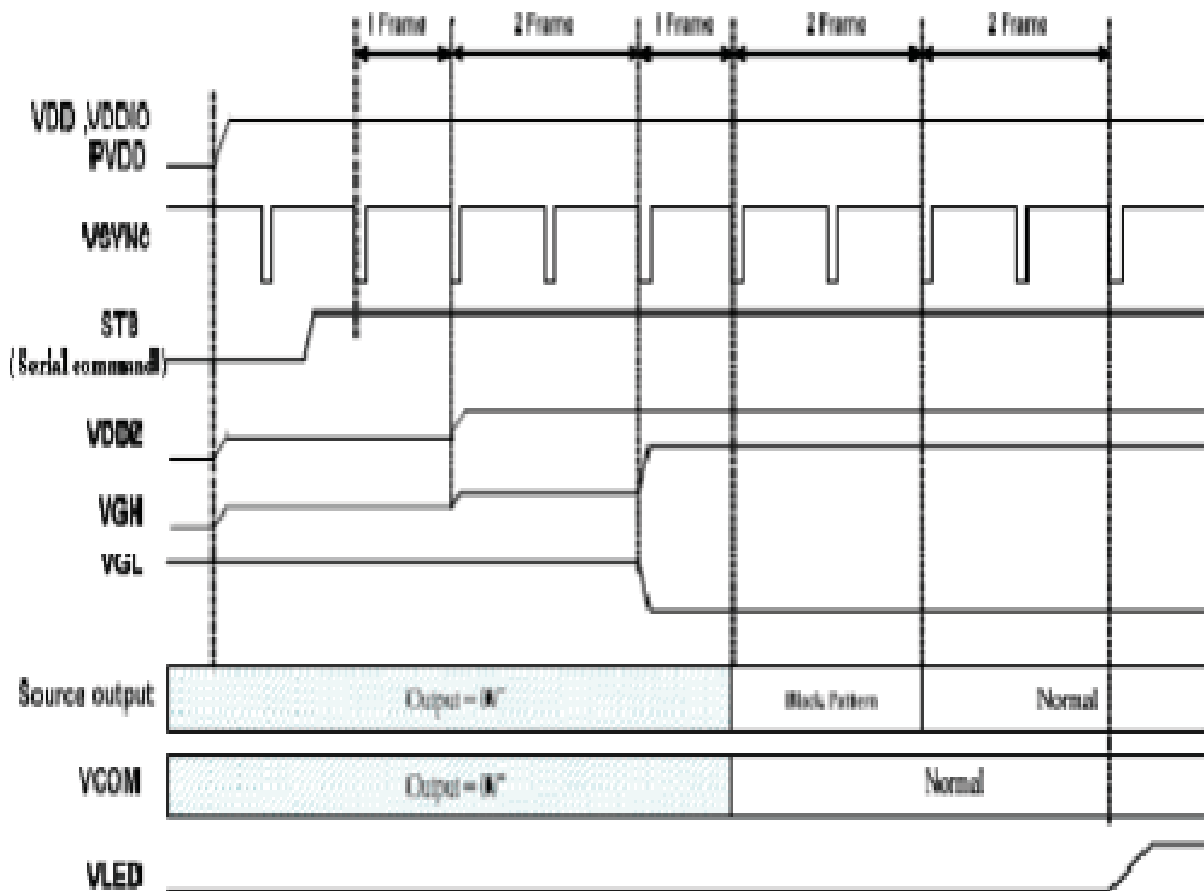

Power Off Sequence

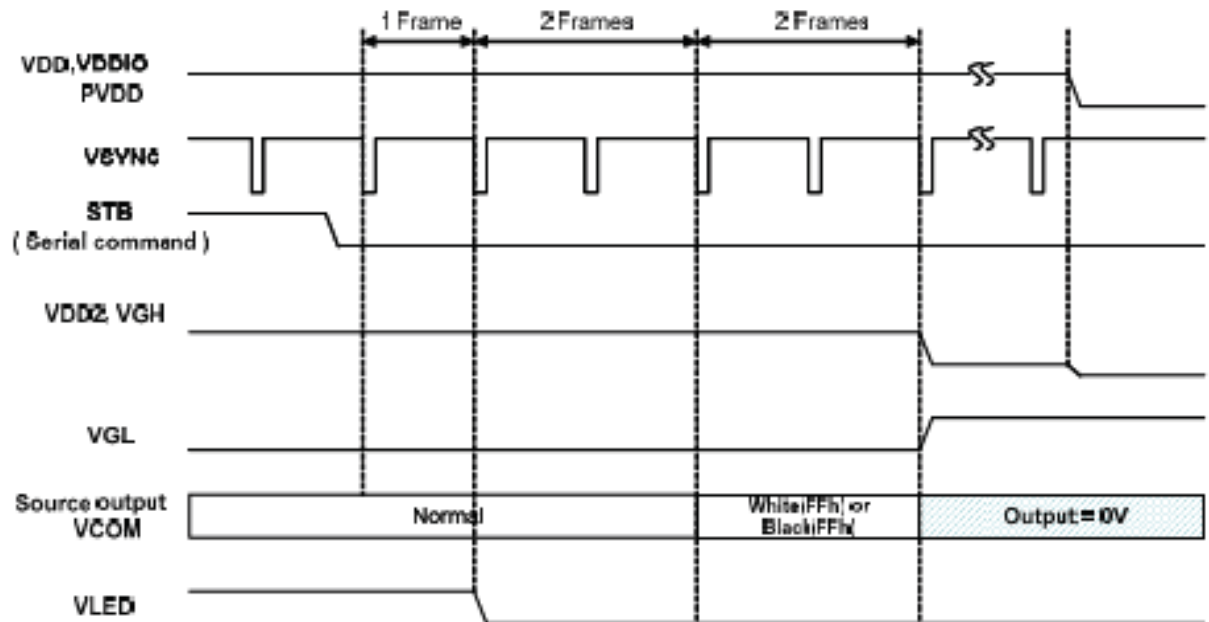

Note:

- When normally-black LC is used, please send black pattern to discharge the panel.
- When normally-white LC is applied, please send white pattern to discharge the pane

6. INPUT SIGNAL TIMING

6.1 AC Characteristics

VDDIO=1.8V, VDD = 3.3V, AVDD = 6V, AGND = 0V, TA = -20°C to 80°C

Item	Symbol	Min	Typ	Max	Unit	Note
CLK pulse duty	T _{cd}	40	50	60	%	
Hsync width	T _{hw}	1.0	-	-	DCLK	
Hsync period	T _h	55	60	65	us	
Vsync setup time	T _{vst}	12	-	-	ns	
Vsync hold time	T _{vhd}	12	-	-	ns	
Hsync setup time	T _{hst}	12	-	-	ns	
Hsync hold time	T _{hhd}	12	-	-	ns	
Data set-up time	T _{dsu}	12	-	-	ns	
Data hold time	T _{dhd}	12	-	-	ns	
DE set-up time	T _{desu}	12	-	-	ns	
DE hold time	T _{dehd}	12	-	-	ns	
SD output stable time	T _{st}	-	10	12	us	
GD output rise and fall time	T _{gst}	-	500	1000	ns	

6.2 AC Timing Diagram

Clock and Data Input Timing Diagram

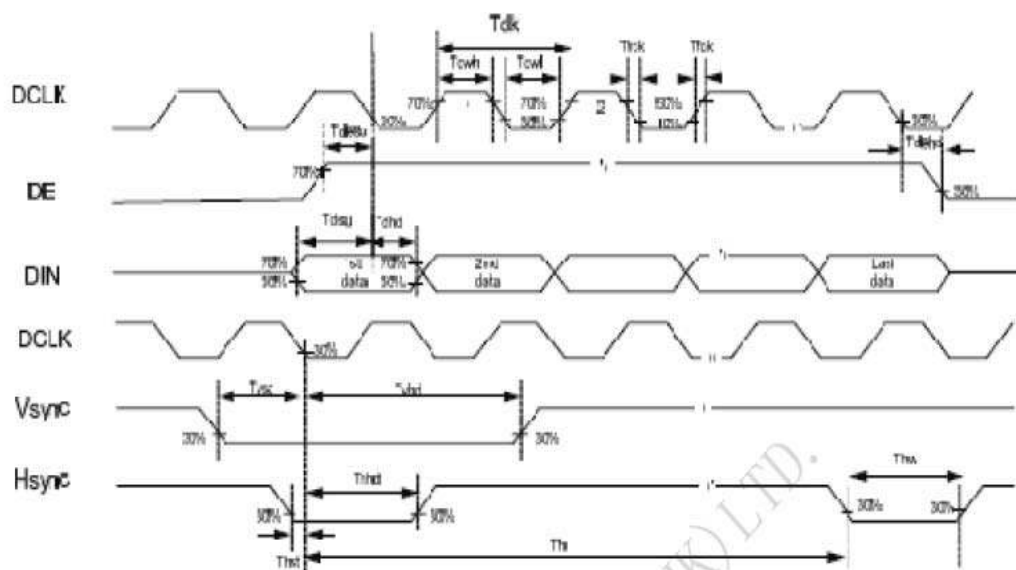

6.3 Parallel RGB Data Format

6.3.1 Parallel RGB Input Timing Table

Item	Symbol	Min	Typ	Max	Unit	Note	
DCLK Frequency	Fclk	5	9	12	MHz		
DCLK Period	Tclk	83	110	200	ns		
Hsync	Period Time	Th	490	531	605	DCLK	
	Display Period	Thdisp		480		DCLK	
	Back Porch	Thbp	8	43		DCLK	By H_BLANKING Setting
	Front Porch	Thfp	2	8		DCLK	
	Pulse Width	Thw	1			DCLK	
Vsync	Period Time	Tv	275	288	335	H	
	Display Period	Tvdisp		272		H	
	Back Porch	Tvbp	2	12		H	By V_BLANKING Setting
	Front Porch	Tvfp	1	4		H	
	Pulse Width	Tvw	1	10		H	

6.3.1 SYNC Mode Timing Diagram

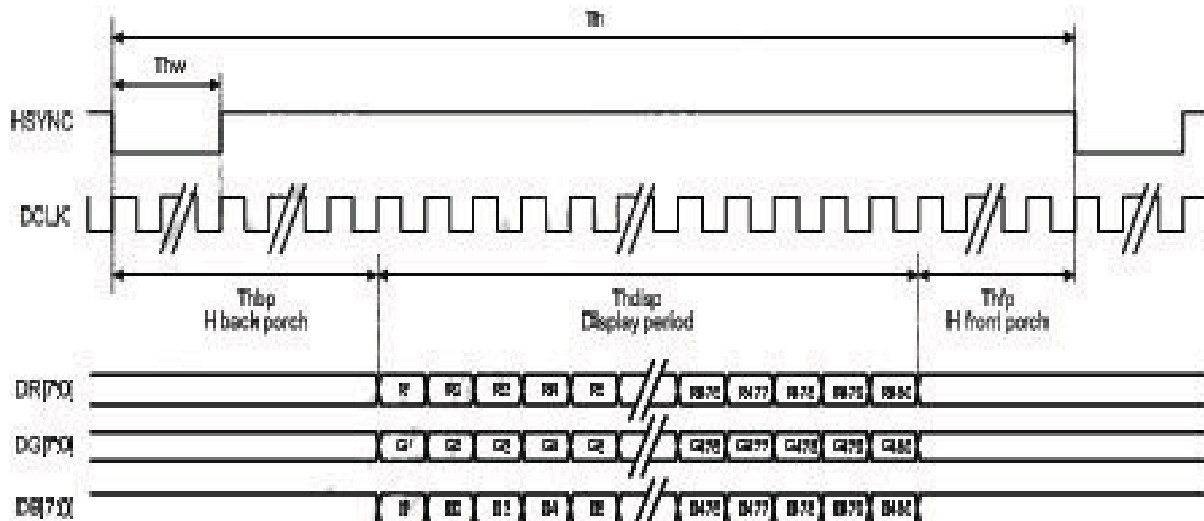

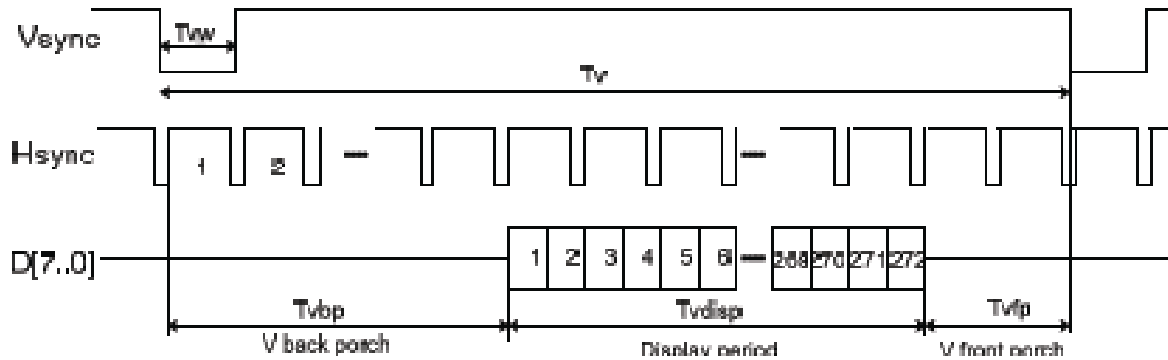

6.3.2 SYNC-DE Mode Timing Diagram

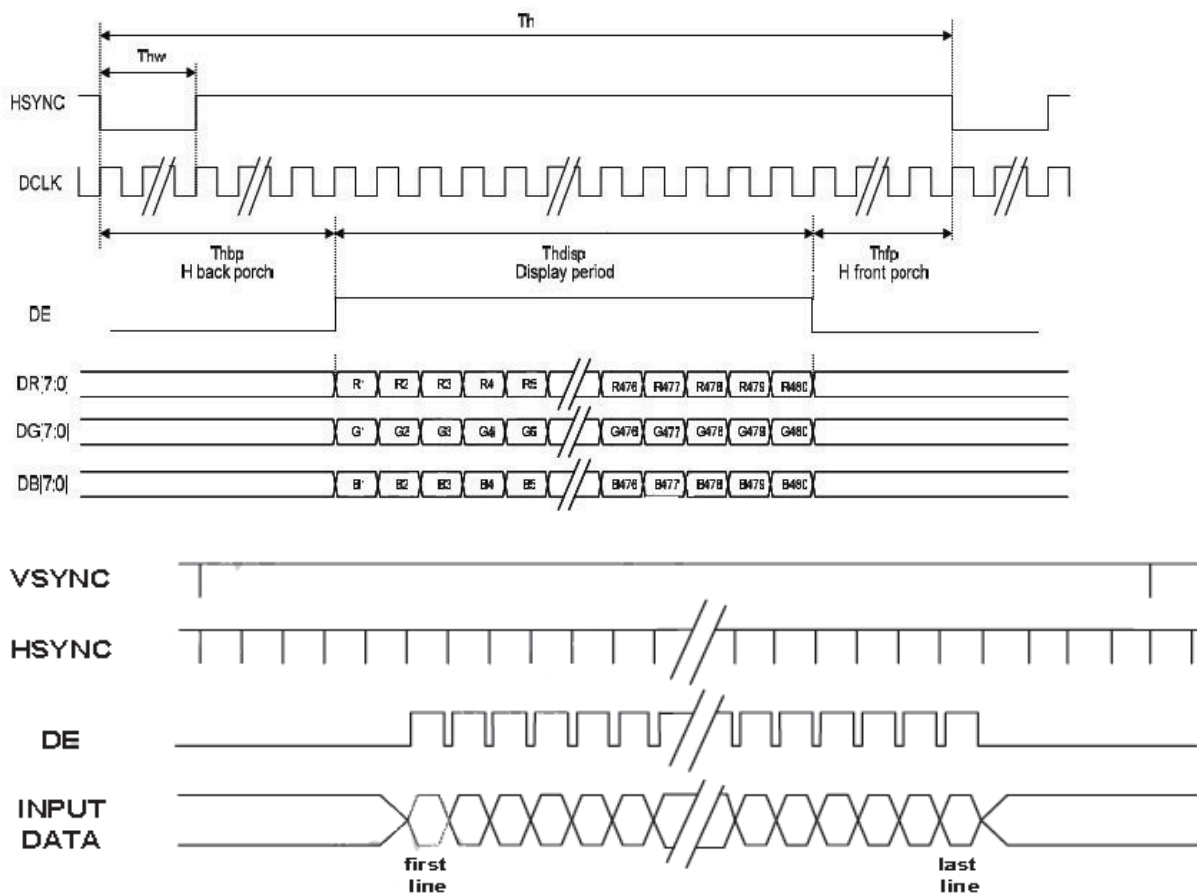

6.4 Controller Information

IC: OTA5180A

Please download IC specification at <http://www.orientdisplay.com/pdf/OTA5180A.pdf>

7. OPTICAL CHARACTERISTICS

Item	Symbol	Condition	Min	Typ	Max	Unit	Note
Contrast Ratio	CR	*1)		400	-	-	Note 3
Luminance	B			560		cd/m ²	
Response Time	Tr+ Tf	*3)	-	30	45	ms	Note 4
Color Filter Chromaticity with C light	White	x	$\Theta=\phi=0^\circ$	0.234	0.284	0.334	Note 6
		y		0.273	0.323	0.373	
	Red	x	$\Theta=\phi=0^\circ$	0.515	0.565	0.615	
		y		0.284	0.334	0.384	
	Green	x	$\Theta=\phi=0^\circ$	0.286	0.336	0.386	
		y		0.520	0.570	0.620	
	Blue	x	$\Theta=\phi=0^\circ$	0.094	0.144	0.194	
		y		0.062	0.112	0.162	
View angle	Ver.	$\theta^{*2)}$	$CR \geq 10$	90	110	-	Note 5
						-	
	Hor.	$\psi^{*2)}$		110	130	-	
						-	

Note1: Ambient condition : 25°C±2°C , 60±10%RH , under 10 Lux in the darkroom.

Note2: Measure device : BM-7 , viewing cone=1° , IL=20mA

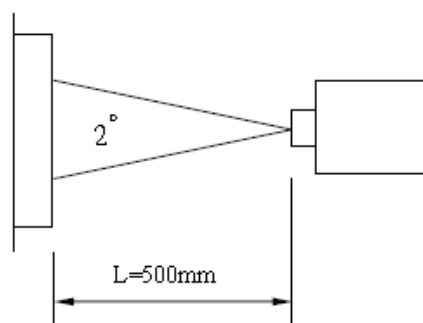

Note3: Definition of Contrast Ratio:

$$CR = \text{White Luminance (ON)} / \text{Black Luminance (OFF)}$$

Note4: Definition of response time : The response time is defined as the time interval between the 10% and 90% amplitudes.

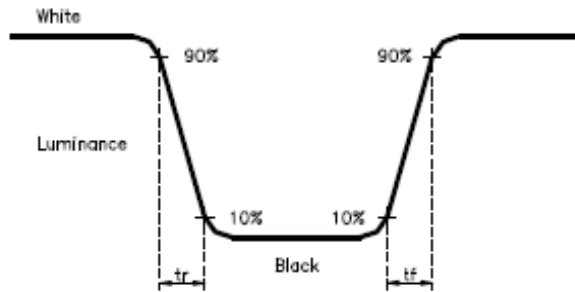

Note5: Definition of viewing angle (θ , ψ):

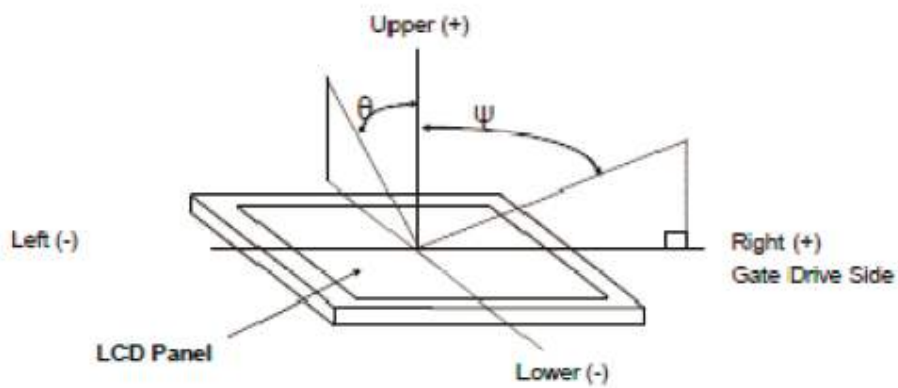

Definition of viewing angle

Note6: Light source: C light



Doc.No.: AFY480272A0-4.3N6NTM

REV : A0

PAGE : 17/18

EFFECTIVE DATE : 2013-01-29

8. RELIABILITY

Please download details at <http://www.orientdisplay.com/Reliability.html>

9. SPECIFICATION OF QUALITY ASSURANCE

Please download details at <http://www.orientdisplay.com/Delivery-TFT.html>

10. GENERAL PRECARUTIONS

Please download details at <http://www.orientdisplay.com/General-Precautions.html>

11. LIMITED WARRANTY

Please download details at <http://www.orientdisplay.com/Warranty.html>

12. PACKAGE

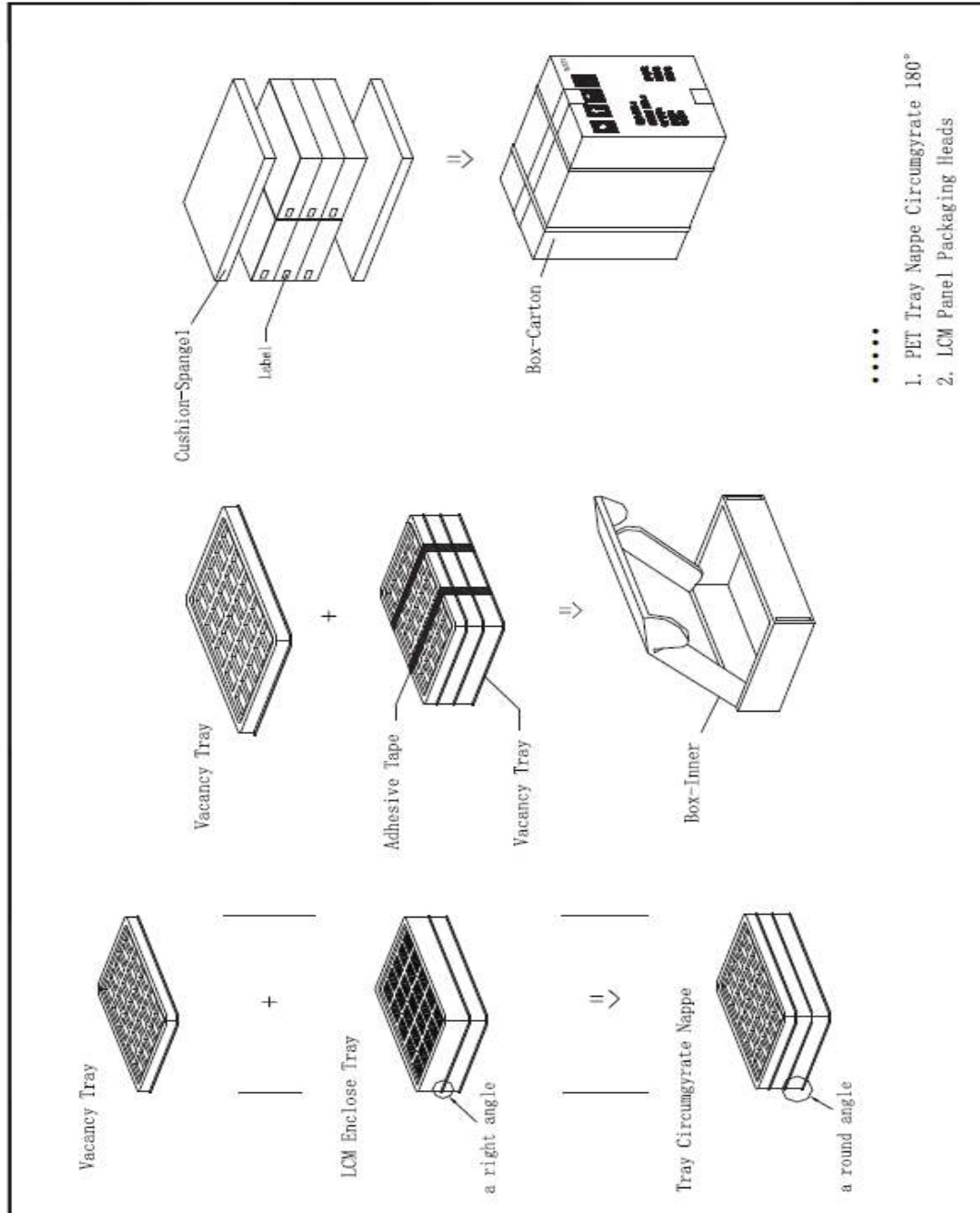

Orient Display Corporation reserves the right to change this specification.