

### FEATURES

- Wideband (20 kHz) single-channel signal conditioning module.**
- Module Bandwidth is user-selectable between 20 kHz and 100Hz, with user-supplied filter caps installed in the optional AC1310 ranging card.**
- Interfaces, amplifies, and filters signals from balanced 4-arm full-bridge strain-gage bridges.**
- Module provides simultaneous precision voltage and current outputs.**
- Module circuitry can withstand 130v rms at the input screw-terminals**
- All 3B18 series modules are mix-and-match and Hot Swappable**

### APPLICATIONS

- Industrial signal conditioning**
- Industrial signal isolation**
- Industrial signal filtering**

### PRODUCT OVERVIEW

The 3B Series of Signal Conditioning I/O Subsystems provide a low-cost, versatile method of transferring analog transducer signals to a data acquisition, monitoring or control system without the inherent noise, non-linearity, drift and extraneous voltages. The modules are designed to directly accept analog signals from Thermocouples, RTD's, AC and DC Strain Gages, Torque Transducers, Frequency Transducers, LVDTs, millivolt or process current signals. The modules amplify, isolate, linearize and convert the transducer output signals to standardized analog inputs for high-level analog I/O subsystems. The 3B Series Subsystem consists of a 10" relay rack with universal mounting backplane and a family of plug-in (up to 16 per rack) input and output signal conditioning modules.

Eight and four channel backplanes are also available. Each backplane incorporates screw terminals for sensor inputs and current outputs and a 26-pin connector for high-level single-ended voltage outputs to the user's equipment.

The input modules feature complete signal conditioning circuitry optimized for specific sensors or analog signals and provide two simultaneous high-level analog outputs: 0 to +10V (or  $\pm 10V$ ) and 4-20 mA (or 0-20 mA).

#### Rev. 0

Information furnished by Analog Devices is believed to be accurate and reliable. However, no responsibility is assumed by Analog Devices for its use, nor for any infringements of patents or other rights of third parties that may result from its use. Specifications subject to change without notice. No license is granted by implication or otherwise under any patent or patent rights of Analog Devices. Trademarks and registered trademarks are the property of their respective companies.

### FUNCTIONAL BLOCK DIAGRAM

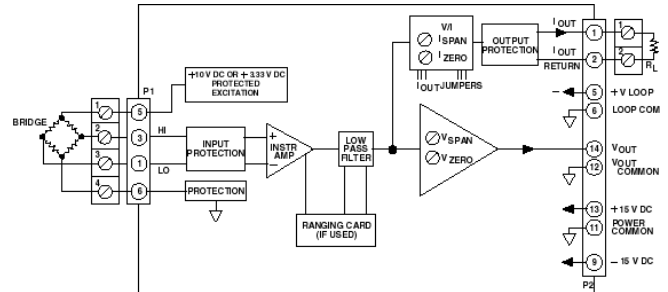

Figure 1. 3B18 Functional Block Diagram

Output modules accept 0 to +10V (or  $\pm 10V$ ) single-ended signals and provide an isolated 4-20 mA (or 0-20 mA) process signal. All modules feature a universal pin-out and may be readily hot-swapped under full power and interchanged without disrupting field wiring.

The Analog Devices 3B Series Signal Conditioning Subsystem is designed to easily handle signal conditioning problems in measurement and control applications. Some typical uses are in microcomputer-based data acquisition systems, programmable controllers, analog recorders, dedicated control systems, and any other applications where monitoring of temperature, pressure, flow and analog signals are required. Since each input module features two simultaneous outputs, the voltage output can be used to provide an input to a microprocessor-based data acquisition or control system while the current output can be used for analog transmission, operator interface, or an analog backup system.

Each input module is a single-channel signal conditioner which plugs into a socket on the backplane and accepts its signal from the input screw terminals. All input modules provide input protection, amplification and filtering of the input signal, accuracy of  $\pm 0.1\%$ , low drift of  $\pm 1 \mu V/^\circ C$  (low-level input modules), and feature two high-level analog outputs that are compatible with most process instrumentation. The isolated input modules also provide  $\pm 1500 V$  peak isolation.

The choice of a specific 3B module depends upon the type of input signal. Input modules are available to accept millivolt, volt, process current, thermocouple, RTD, AC and DC strain gage, frequency and LVDT inputs. The voltage output of each module is available from the system I/O connector while the current output is available on the output screw terminals.

## GENERAL DESCRIPTION

The 3B18 is a wideband (20kHz) single-channel signal conditioning module which interfaces, amplifies, and filters signals from balanced 4-arm full-bridge strain-gage bridges with a resistance from 100 $\Omega$  to 10 k $\Omega$ , providing simultaneous precision voltage and current outputs. The module provides two user-selectable (via front-panel switches) bridge excitation voltages: +10 V for bridges with a load impedance down to 300W or +3.33V for 120W bridges or others below 300W. Module bandwidth is also user-selectable between 20 kHz and 100 Hz, with user-supplied filter capacitors installed in the optional AC1310 ranging card. The 3B18 protects the computer side from damage due to field-side over-voltage faults up to 130V rms. In addition, the current output withstands 130V rms without damage and interfaces user equipment through screw terminals located on the 3B Series backplane. The 3B18 is a plug-in, mix-and-match, hot-swappable module which is easily field calibrated via front-panel zero and span adjustments for

both voltage and current outputs.

**3B Series Custom-Ranging Program** – Externally-programmable Model 3B18-00, enables the user to configure a special input range by using the optional plug-on AC1310 ranging card, which houses user-supplied resistors to determine zero and span. To facilitate selecting resistors, a Windows program, 3B-CUSTOM, calculates resistor values based on the user-desired input/output ranges.

A chopper-stabilized low-drift ( $\pm 1\mu\text{V}/^\circ\text{C}$ ) input amplifier assures long-term stability. For user convenience, the zero and span can be factory configured to meet custom range needs (Model 3B18-CUSTOM) or can be externally programmed (Model 3B18-00) via user supplied resistors inserted in the optional AC1310 plug-on ranging card.



Figure 2

## 3B18 Models Available

| Model       | Input Bridge | Input Range                          | Excitation <sup>1</sup> | Sensitivity                          | Output Ranges                  |
|-------------|--------------|--------------------------------------|-------------------------|--------------------------------------|--------------------------------|
| 3B18-00     | Full Bridge  | Externally Programmable <sup>3</sup> | +10.0 V or +3.33 V      | Externally Programmable <sup>3</sup> | -10 V to +10 V & 0 mA to 20 mA |
| 3B18-01     | Full Bridge  | -30 mV to +30 mV                     | +10.0 V or +3.33 V      | 3 mV/V @ 10 V <sub>exc</sub>         | -10 V to +10 V & 0 mA to 20 mA |
| 3B18-02     | Full Bridge  | -10 mV to +10 mV                     | +10.0 V or +3.33 V      | 3 mV/V @ 3.33 V <sub>exc</sub>       | -10 V to +10 V & 0 mA to 20 mA |
| 3B18-Custom | Full Bridge  | *                                    | +10.0 V or +3.33 V      | *                                    | *                              |

<sup>1</sup> Output current range may be user programmed to 4 mA to 20 mA using jumper supplied.

<sup>2</sup> Requires AC1310 ranging card.

\* Custom Input/Output ranges are available. Refer to configuration guide.

## 3B18 Specifications

(typical @ +25°C and ±15 V dc, and +24 V dc Power)

| Description                                       | Model 3B18  |
|---|---|
|   | <b>Input Range</b>  |
| Standard Range                                    | ±30 mV (3 mV/V sensitivity @ V <sub>exc</sub> = +10V)<br>±10 mV (3 mV/V sensitivity @ V <sub>exc</sub> = +3.33 V) |
| Custom Ranges                                     | ±5 mV to ±500   |
|   | <b>Output Range</b>   |
| Voltage (R <sub>L</sub> > 2 KΩ)                   | -10 V to +10 V  |
| Current (R <sub>L</sub> = 0 to 850Ω) <sup>1</sup> | 4 mA to 20 mA or 0 mA to 20 mA  |
| Maximum Current Output Span                       | 0 mA to 31 mA   |
|   | <b>Accuracy<sup>2</sup></b>   |
| Initial @ +25°C                                   | ±0.1% Span  |
| Nonlinearity <sup>2</sup>                         | ±0.01% Span   |
|   | <b>Stability vs. Temperature</b>  |
| Voltage Output                                    |   |
| Zero  | ±3 μV/°C (RTI)  |
| Span  | ±25 ppm of Reading/°C   |
| Current Output <sup>3</sup>                       |   |
| Zero  | ±25 ppm of Span/°C  |
| Span  | ±25 ppm of Reading/°C   |
|   | <b>Bridge Excitation</b>  |
| Voltage user-selectable                           | +10 V or +3.33 V  |
| Voltage, tolerance                                | ±2%   |
| Voltage vs. Temperature                           | ±0.0015%/°C   |
|   | <b>Bridge Resistance Range</b>  |
| V <sub>exc</sub> = +10.0 V                        | 300 Ω to 1 kΩ   |

|  |  |
|--|--|
| $V_{exc} = +3.33 \text{ V}$                            | 100 $\Omega$ to 10 k $\Omega$                            |
| <b>Zero and Span Adjustment Range<sup>4</sup></b>      | $\pm 5\%$ of Span  |
| <b>Input Bias Current</b>                              | +25 nA   |
| <b>Input Resistance</b>                                | 100 M $\Omega$   |
| <b>Bandwidth, -3 dB</b>                                | 20 kHz   |
| <b>Output Rise Time, 10% to 90% Span</b>               | 24 $\mu$ s   |
| <b>Common-Mode Voltage (CMV)</b>                       |  |
| Input-to-Output, Continuous                            | $\pm 10 \text{ V}$ peak, maximum                         |
| Transient  | ANSI/IEEE C37.90.1- 1989                                 |
| <b>Common Mode Rejection (CMR)</b>                     |  |
| 1 k $\Omega$ Source Imbalance, 50/60 Hz                | 100 dB   |
| <b>Input Protection, Signal and Excitation Voltage</b> |  |
| Continuous   | 130 V rms maximum  |
| Transient  | ANSI/IEEE C37.90.1-1989                                  |
| <b>Voltage Output Protection</b>                       | Continuous Short to Ground                               |
| <b>Current Output Protection</b>                       | 130 V rms, continuous                                    |
| <b>Power Supply Voltages<sup>5</sup></b>               |  |
| $\pm 15 \text{ V}$ dc Supplies                         |  |
| Rated Operation  | $\pm(13.5 \text{ V}$ dc to $16.5 \text{ V}$ dc)          |
| Current  | +50 mA, -15 mA   |
| Sensitivity  | $\pm 0.01\%$ span/V                                      |
| $+24 \text{ V}$ dc Loop Supply                         |  |
| Rated Operation  | +12 V dc to +30 V dc                                     |
| Current  | +27 mA @ $I_{out} = 20 \text{ mA}$                       |
| Sensitivity  | $\pm 0.0002\%$ span/V                                    |
| <b>Mechanical Dimensions</b>                           | 3.15" x 3.395" x 0.775"<br>(80.0 mm x 86.2 mm x 19.7 mm) |
| <b>Environmental</b>                                   |  |
| Temperature Range                                      |  |
| Rated Performance                                      | -25°C to +85°C   |
| Storage  | -55°C to +85°C   |
| Relative Humidity, 24 hours                            | 0 to 95% @ +60°C non-condensing                          |
| RFI Susceptibility                                     | $\pm 0.5\%$ Span error @ 400 MHz, 5 Watt, 3 ft           |

<sup>1</sup> For a 0 mA to 20 mA range, a typical minimum output current is 10  $\mu$ A.

<sup>2</sup> Includes the combined effects of repeatability, hysteresis, and nonlinearity.

<sup>3</sup> With respect to the voltage output.

<sup>4</sup> A wide range of custom zero suppression and span is available with the 3B18-00 model, using the AC1310 ranging card.

<sup>5</sup> +24 V dc loop power is required for driving the current output at loads up to 850 $\Omega$ . If a current output load of 400 $\Omega$  or less is applied, +15 V dc is sufficient for loop power. If only voltage output is used, loop power is not required.

# PIN CONFIGURATIONS AND FUNCTIONAL DESCRIPTIONS

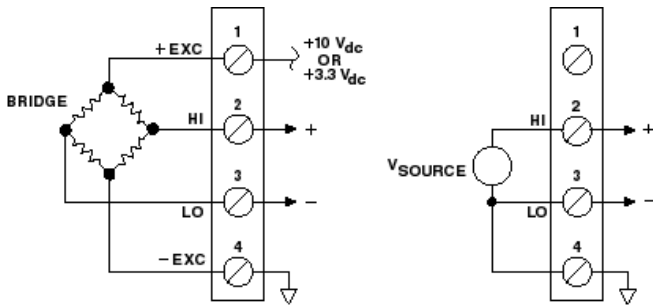

Figure 3 3B18 Input Field Connections

Table 1. Pin Function Descriptions—

| Pin No. | Description |
|---------|-------------|
| 1       | +EXC        |
| 2       | HI          |
| 3       | LO          |
| 4       | -EXC        |

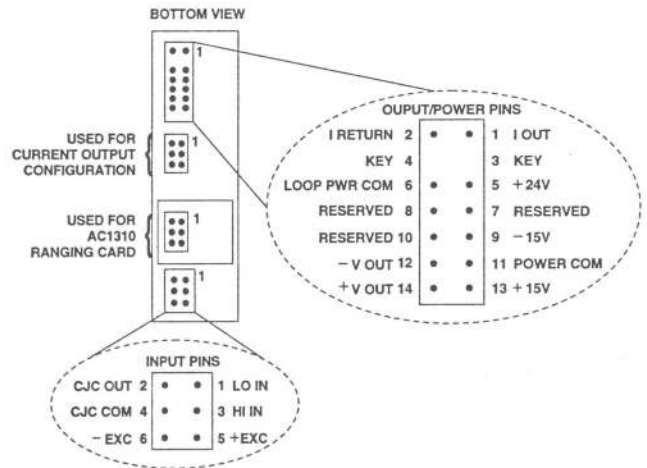

Figure 4 . Model 3B Series Module, with pin-out assignments.

## ESD CAUTION

ESD (electrostatic discharge) sensitive device. Electrostatic charges as high as 4000 V readily accumulate on the human body and test equipment and can discharge without detection. Although this product features proprietary ESD protection circuitry, permanent damage may occur on devices subjected to high energy electrostatic discharges. Therefore, proper ESD precautions are recommended to avoid performance degradation or loss of functionality.



## OUTLINE DIMENSIONS

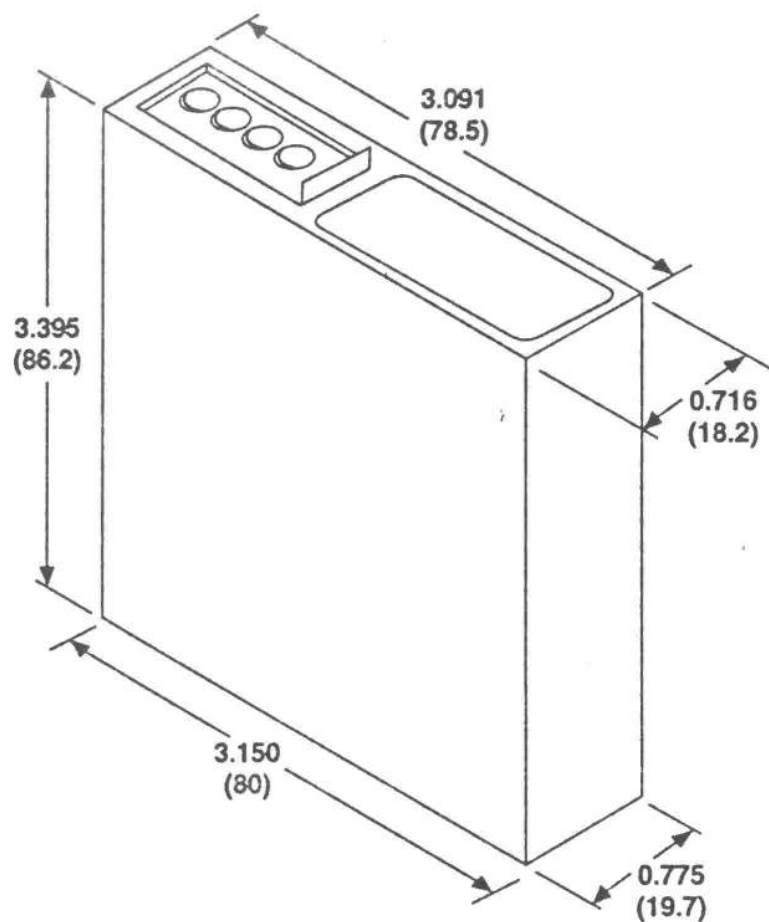

Figure 5. Outline Dimensions

**NOTES**

**NOTES**