

13 12 11 10 9 8 7 6 5 4 3 2 1

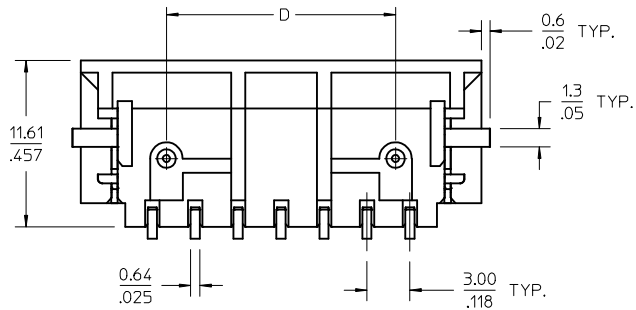
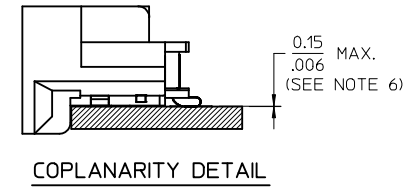
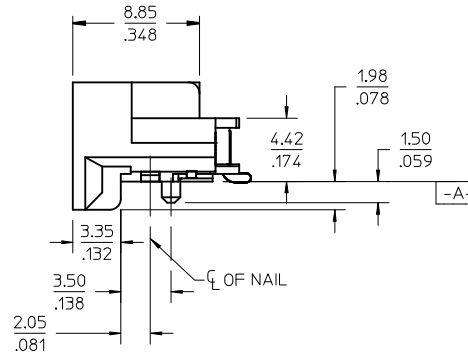
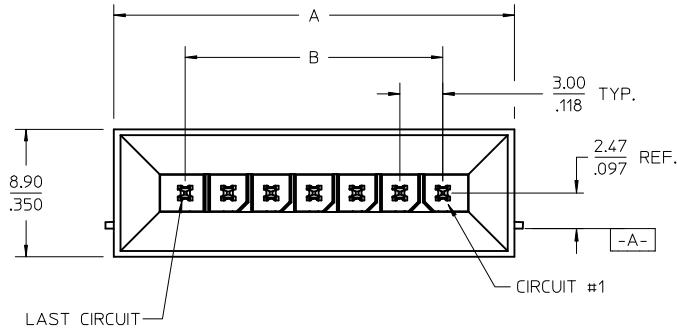
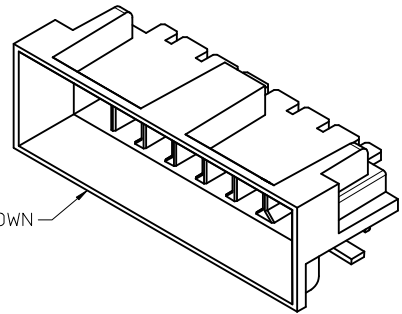
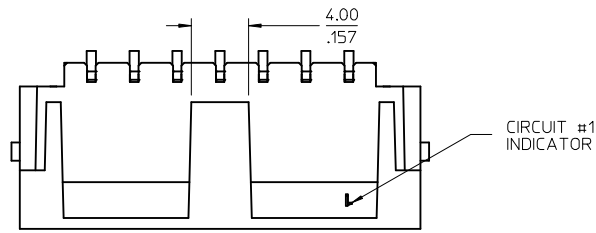

NOTES:

- MATERIALS -
HOUSING: LCP, GLASS FILLED, UL94V-0, COLOR - BLACK
TERMINAL: BRASS ALLOY
- FINISH:
A = 0.00152/.000060 MIN REFLOWED MATTE TIN OVER 0.00127/.000050 MIN NICKEL (FINISH IS BRIGHT IN APPEARANCE. THICKNESS AS APPLIED PRIOR TO REFLOW.)
B = 0.00038/.000015 MIN. SELECT GOLD IN CONTACT AREA.
0.00254/.000100 MIN. SELECT MATTE TIN ON SOLDER TAILS.
BOTH OVER 0.00127/.000050 MIN. NICKEL.
C = 0.00076/.000030 MIN. SELECT GOLD IN CONTACT AREA;
0.00254/.000100 MIN. SELECT MATTE TIN ON SOLDER TAILS;
BOTH OVER 0.00127/.000050 MIN. NICKEL.
- PRODUCT SPECIFICATION: PS-44300-001
- PACKAGING SPECIFICATION: TAPE AND REEL PACKAGED PER PK-46622-001
- THIS ASSEMBLY MATES WITH MOLEX BMI SINGLE ROW PANEL MOUNT RECEPTACLE (SEE DRAWING SD-46623-001) AND FEMALE CRIMP TERMINAL (SEE DRAWING SD-43030-**** OR SD-46235-001).
- THE COPLANARITY DIMENSION IS ESTABLISHED BY PLACING THE ASSEMBLY ON A FLAT SURFACE. THE DISTANCE FROM THAT SURFACE TO THE BOTTOM OF ANY TERMINAL OR NAIL MUST NOT EXCEED 0.15/.006.
- THIS PART CONFORMS TO CLASS B REQUIREMENTS OF COSMETIC SPECIFICATION PS-45499-002.

SEE PCB LAYOUTS SHT. 2

ADD PCB LAYOUTS EC NO: UCP2017-1972 DRWN: JSCHAFFER 2016/03/02 CHKD: APPR: FSMITH 2017/06/28 REV	QUALITY SYMBOLS	GENERAL TOLERANCES (UNLESS SPECIFIED)		DIMENSION STYLE MM/IN		SCALE 4:1	DESIGN UNITS METRIC	THIRD ANGLE PROJECTION
	▽=0	mm	INCH	DRAWN BY JSCHAFFER	DATE 2016/03/02	TITLE MICRO-FIT (3.0) BMI SINGLE ROW 2-12 CKTS SMT HEADER - NAIL		
	▽=0	4 PLACES ± --- ± ---	3 PLACES ± --- ± .010	CHECKED BY	DATE	MATERIAL NO. SD-46622-0000		
	▽=0	2 PLACES ± 0.25 ± .015	1 PLACE ± 0.38 ± ---	APPROVED BY FSMITH	DATE 2017/06/28	DOCUMENT NO. 1 OF 2		
		ANGULAR ±1/2°		SEE CHART		SHEET NO. 1 OF 2		
		DRAFT WHERE APPLICABLE MUST REMAIN WITHIN DIMENSIONS		THIS DRAWING CONTAINS INFORMATION THAT IS PROPRIETARY TO MOLEX INCORPORATED AND SHOULD NOT BE USED WITHOUT WRITTEN PERMISSION				

12 11 10 9 8 7 6 5 4 3 2 1

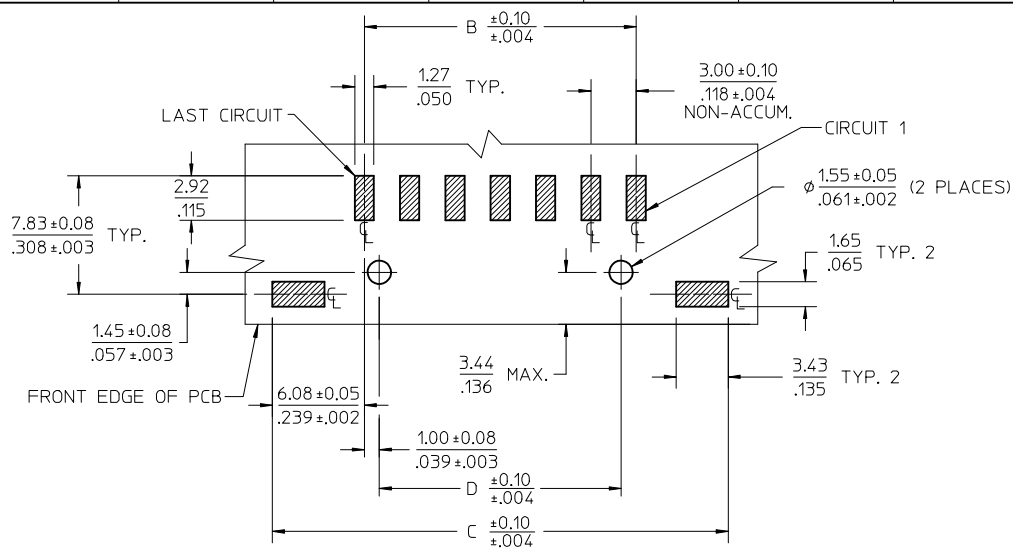

PCB LAYOUT: COMPONENT SIDE
4-12 CKT CONFIGURATION

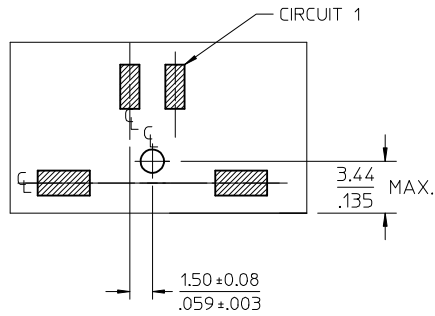

2 CKT CONFIGURATION
SEE 4-12 CKT LAYOUT FOR ADDITIONAL DIMENSIONS

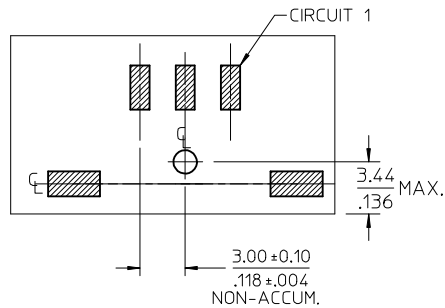

3 CKT CONFIGURATION
SEE 4-12 CKT LAYOUT FOR ADDITIONAL DIMENSIONS

CIRCUIT SIZE	MATERIAL NUMBER	PLATING OPTION	A	B	C	D
02	46622-0200	A	13.00	3.00	15.16	N/A
	46622-0201	B	.512	.118	.597	N/A
	46622-0202	C				
03	46622-0300	A	16.00	6.00	18.16	N/A
	46622-0301	B	.630	.236	.715	N/A
	46622-0302	C				
04	46622-0400	A	19.00	9.00	21.16	7.00
	46622-0401	B	.748	.354	.833	.276
	46622-0402	C				
05	46622-0500	A	22.00	12.00	24.16	10.00
	46622-0501	B	.866	.472	.951	.394
	46622-0502	C				
06	46622-0600	A	25.00	15.00	27.16	13.00
	46622-0601	B	.984	.591	1.069	.512
	46622-0602	C				
07	46622-0700	A	28.00	18.00	30.16	16.00
	46622-0701	B	1.102	.709	1.187	.630
	46622-0702	C				
08	46622-0800	A	31.00	21.00	33.16	19.00
	46622-0801	B	1.220	.827	1.306	.748
	46622-0802	C				
09	46622-0900	A	34.00	24.00	36.16	22.00
	46622-0901	B	1.339	.945	1.424	.866
	46622-0902	C				
10	46622-1000	A	37.00	27.00	39.16	25.00
	46622-1001	B	1.457	1.063	1.542	.984
	46622-1002	C				
11	46622-1100	A	40.00	30.00	42.16	28.00
	46622-1101	B	1.575	1.181	1.660	1.102
	46622-1102	C				
12	46622-1200	A	43.00	33.00	45.16	31.00
	46622-1201	B	1.693	1.299	1.778	1.220
	46622-1202	C				

SEE SHT 1 EC NO: UCP2017-1972 DRWN: JSCHAER 2016/03/02 CHKD: CHKD: APPR: FSMITH 2017/06/28	QUALITY SYMBOLS ∇=0 ∇=0 ∇=0	GENERAL TOLERANCES (UNLESS SPECIFIED) <table border="1"> <tr> <td></td> <td>mm</td> <td>INCH</td> </tr> <tr> <td>4 PLACES ±</td> <td>---</td> <td>---</td> </tr> <tr> <td>3 PLACES ±</td> <td>---</td> <td>±.010</td> </tr> <tr> <td>2 PLACES ±</td> <td>0.25</td> <td>±.015</td> </tr> <tr> <td>1 PLACE ±</td> <td>0.38</td> <td>---</td> </tr> <tr> <td>0 PLACE ±</td> <td>---</td> <td>---</td> </tr> </table>		mm	INCH	4 PLACES ±	---	---	3 PLACES ±	---	±.010	2 PLACES ±	0.25	±.015	1 PLACE ±	0.38	---	0 PLACE ±	---	---	DIMENSION STYLE MM/IN	SCALE 4:1	DESIGN UNITS METRIC	THIRD ANGLE PROJECTION
		mm	INCH																					
	4 PLACES ±	---	---																					
	3 PLACES ±	---	±.010																					
2 PLACES ±	0.25	±.015																						
1 PLACE ±	0.38	---																						
0 PLACE ±	---	---																						
DRAFT WHERE APPLICABLE MUST REMAIN WITHIN DIMENSIONS		DRAWN BY JSCHAER	DATE 2016/03/02	TITLE MICRO-FIT (3.0) BMI SINGLE ROW 2-12 CKTS SMT HEADER - NAIL																				
APPROVED BY FSMITH		DATE 2017/06/28		molex																				
MATERIAL NO. SEE CHART		DOCUMENT NO. SD-46622-0000		SHEET NO. 2 OF 2																				

13 12 11 10 9 8 7 6 5 4 3 2 1

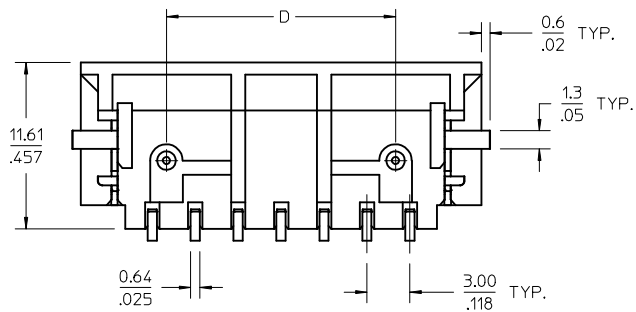
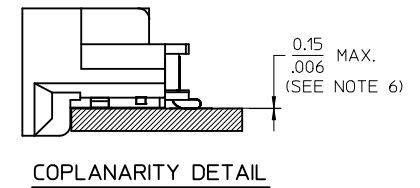
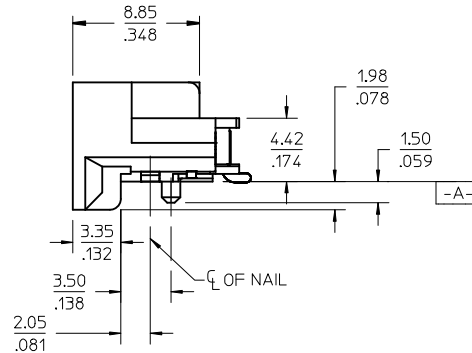
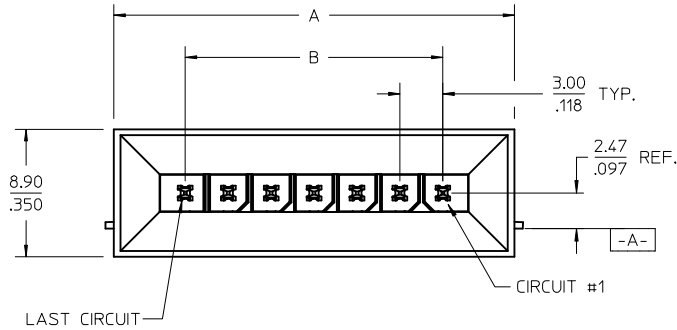
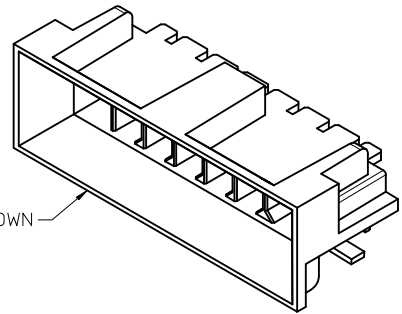
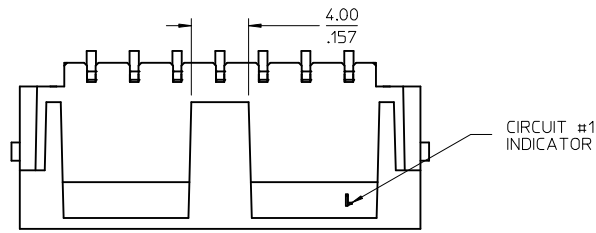

NOTES:

- MATERIALS -
HOUSING: LCP, GLASS FILLED, UL94V-0, COLOR - BLACK
TERMINAL: BRASS ALLOY
- FINISH:
A = 0.00152/.000060 MIN REFLOWED MATTE TIN OVER 0.00127/.000050 MIN NICKEL (FINISH IS BRIGHT IN APPEARANCE. THICKNESS AS APPLIED PRIOR TO REFLOW.)
B = 0.00038/.000015 MIN. SELECT GOLD IN CONTACT AREA.
0.00254/.000100 MIN. SELECT MATTE TIN ON SOLDER TAILS.
BOTH OVER 0.00127/.000050 MIN. NICKEL.
C = 0.00076/.000030 MIN. SELECT GOLD IN CONTACT AREA;
0.00254/.000100 MIN. SELECT MATTE TIN ON SOLDER TAILS;
BOTH OVER 0.00127/.000050 MIN. NICKEL.
- PRODUCT SPECIFICATION: PS-44300-001
- PACKAGING SPECIFICATION: TAPE AND REEL PACKAGED PER PK-46622-001
- THIS ASSEMBLY MATES WITH MOLEX BMI SINGLE ROW PANEL MOUNT RECEPTACLE (SEE DRAWING SD-46623-001) AND FEMALE CRIMP TERMINAL (SEE DRAWING SD-43030-**** OR SD-46235-001).
- THE COPLANARITY DIMENSION IS ESTABLISHED BY PLACING THE ASSEMBLY ON A FLAT SURFACE. THE DISTANCE FROM THAT SURFACE TO THE BOTTOM OF ANY TERMINAL OR NAIL MUST NOT EXCEED 0.15/.006.
- THIS PART CONFORMS TO CLASS B REQUIREMENTS OF COSMETIC SPECIFICATION PS-45499-002.

SEE PCB LAYOUTS SHT. 2

ADD PCB LAYOUTS EC NO: UCP2017-1972 DRWN: JSCHAFFER 2016/03/02 CHKD: APPR: FSMITH 2017/06/28 REV: A	DESCRIPTION	QUALITY SYMBOLS	GENERAL TOLERANCES (UNLESS SPECIFIED)		DIMENSION STYLE		SCALE	DESIGN UNITS	THIRD ANGLE PROJECTION
		▽=0	mm	INCH	MM/IN	4:1	METRIC	TITLE MICRO-FIT (3.0) BMI SINGLE ROW 2-12 CKTS SMT HEADER - NAIL molex MATERIAL NO. SD-46622-0000 DOCUMENT NO.	SHEET NO. 1 OF 2
		▽=0	4 PLACES ± .010	± .010	DRAWN BY JSCHAFFER	DATE 2016/03/02	TITLE		
		▽=0	3 PLACES ± .025	± .015	CHECKED BY	DATE			
▽=0	2 PLACES ± .038	± .015	APPROVED BY FSMITH	DATE 2017/06/28					
		1 PLACE ± .038	± .015	ANGULAR ±1/2°		MATERIAL NO.		DOCUMENT NO.	
		0 PLACE ± .038	± .015	DRAFT WHERE APPLICABLE MUST REMAIN WITHIN DIMENSIONS		SIZE C		THIS DRAWING CONTAINS INFORMATION THAT IS PROPRIETARY TO MOLEX INCORPORATED AND SHOULD NOT BE USED WITHOUT WRITTEN PERMISSION	

12 11 10 9 8 7 6 5 4 3 2 1

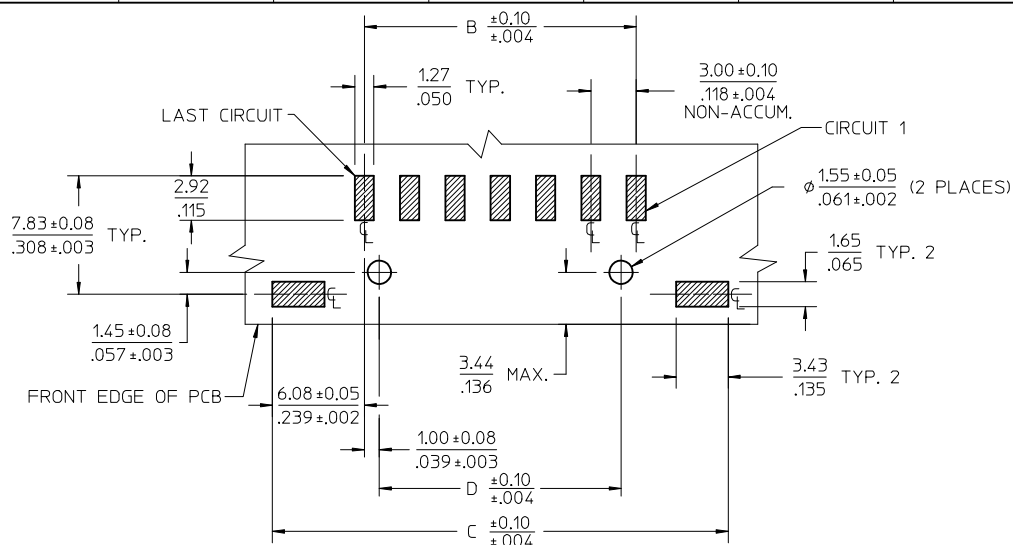

PCB LAYOUT: COMPONENT SIDE

4-12 CKT CONFIGURATION

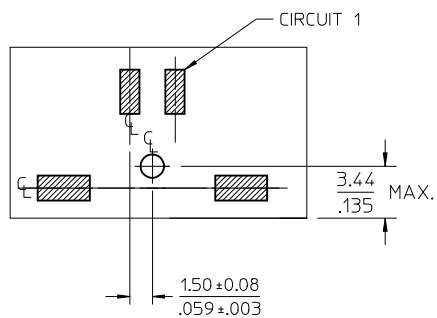

2 CKT CONFIGURATION

SEE 4-12 CKT LAYOUT FOR ADDITIONAL DIMENSIONS

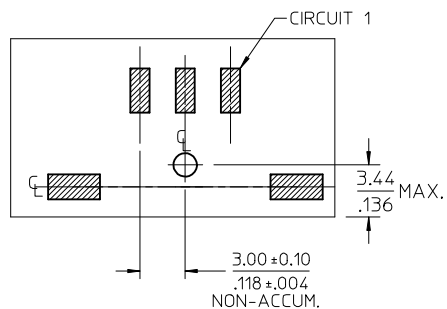

3 CKT CONFIGURATION

SEE 4-12 CKT LAYOUT FOR ADDITIONAL DIMENSIONS

CIRCUIT SIZE	MATERIAL NUMBER	PLATING OPTION	A	B	C	D
02	46622-0200	A	13.00	3.00	15.16	N/A
	46622-0201	B	.512	.118	.597	N/A
	46622-0202	C				
03	46622-0300	A	16.00	6.00	18.16	N/A
	46622-0301	B	.630	.236	.715	N/A
	46622-0302	C				
04	46622-0400	A	19.00	9.00	21.16	7.00
	46622-0401	B	.748	.354	.833	.276
	46622-0402	C				
05	46622-0500	A	22.00	12.00	24.16	10.00
	46622-0501	B	.866	.472	.951	.394
	46622-0502	C				
06	46622-0600	A	25.00	15.00	27.16	13.00
	46622-0601	B	.984	.591	1.069	.512
	46622-0602	C				
07	46622-0700	A	28.00	18.00	30.16	16.00
	46622-0701	B	1.102	.709	1.187	.630
	46622-0702	C				
08	46622-0800	A	31.00	21.00	33.16	19.00
	46622-0801	B	1.220	.827	1.306	.748
	46622-0802	C				
09	46622-0900	A	34.00	24.00	36.16	22.00
	46622-0901	B	1.339	.945	1.424	.866
	46622-0902	C				
10	46622-1000	A	37.00	27.00	39.16	25.00
	46622-1001	B	1.457	1.063	1.542	.984
	46622-1002	C				
11	46622-1100	A	40.00	30.00	42.16	28.00
	46622-1101	B	1.575	1.181	1.660	1.102
	46622-1102	C				
12	46622-1200	A	43.00	33.00	45.16	31.00
	46622-1201	B	1.693	1.299	1.778	1.220
	46622-1202	C				

SEE SHT 1 EC NO: UCP2017-1972 DRWN: JSCHAER 2016/03/02 CHKD: CHKD: APPR: FSMITH 2017/06/28	QUALITY SYMBOLS ▽=0 ▽=0 ▽=0	GENERAL TOLERANCES (UNLESS SPECIFIED) <table border="1"> <tr> <th></th> <th>mm</th> <th>INCH</th> </tr> <tr> <td>4 PLACES ±</td> <td>---</td> <td>---</td> </tr> <tr> <td>3 PLACES ±</td> <td>---</td> <td>±.010</td> </tr> <tr> <td>2 PLACES ±</td> <td>0.25</td> <td>±.015</td> </tr> <tr> <td>1 PLACE ±</td> <td>0.38</td> <td>---</td> </tr> <tr> <td>0 PLACE ±</td> <td>---</td> <td>---</td> </tr> </table>		mm	INCH	4 PLACES ±	---	---	3 PLACES ±	---	±.010	2 PLACES ±	0.25	±.015	1 PLACE ±	0.38	---	0 PLACE ±	---	---	DIMENSION STYLE MM/IN DRAWN BY JSCHAER DATE 2016/03/02 CHECKED BY DATE	SCALE 4:1 DESIGN UNITS METRIC	THIRD ANGLE PROJECTION
		mm	INCH																				
	4 PLACES ±	---	---																				
	3 PLACES ±	---	±.010																				
2 PLACES ±	0.25	±.015																					
1 PLACE ±	0.38	---																					
0 PLACE ±	---	---																					
ANGULAR ±1/2°		APPROVED BY FSMITH DATE 2017/06/28	TITLE MICRO-FIT (3.0) BMI SINGLE ROW 2-12 CKTS SMT HEADER - NAIL																				
DRAFT WHERE APPLICABLE MUST REMAIN WITHIN DIMENSIONS		MATERIAL NO. SEE CHART	DOCUMENT NO. SD-46622-0000	SHEET NO. 2 OF 2																			
THIS DRAWING CONTAINS INFORMATION THAT IS PROPRIETARY TO MOLEX INCORPORATED AND SHOULD NOT BE USED WITHOUT WRITTEN PERMISSION																							