

# HAL<sup>®</sup> 15xy

Hall-Effect Switches  
with Open-Drain Output (3-Wire)  
in TO92 Package

**ASIL**|ready

## Copyright, Warranty, and Limitation of Liability

The information and data contained in this document are believed to be accurate and reliable. The software and proprietary information contained therein may be protected by copyright, patent, trademark and/or other intellectual property rights of TDK-Micronas. All rights not expressly granted remain reserved by TDK-Micronas.

TDK-Micronas assumes no liability for errors and gives no warranty representation or guarantee regarding the suitability of its products for any particular purpose due to these specifications.

By this publication, TDK-Micronas does not assume responsibility for patent infringements or other rights of third parties which may result from its use. Commercial conditions, product availability and delivery are exclusively subject to the respective order confirmation.

Any information and data which may be provided in the document can and do vary in different applications, and actual performance may vary over time.

All operating parameters must be validated for each customer application by customers' technical experts. Any mention of target applications for our products is made without a claim for fit for purpose as this has to be checked at system level.

Any new issue of this document invalidates previous issues. TDK-Micronas reserves the right to review this document and to make changes to the document's content at any time without obligation to notify any person or entity of such revision or changes. For further advice please contact us directly.

Do not use our products in life-supporting systems, military, aviation, or aerospace applications! Unless explicitly agreed to otherwise in writing between the parties, TDK-Micronas' products are not designed, intended or authorized for use as components in systems intended for surgical implants into the body, or other applications intended to support or sustain life, or for any other application in which the failure of the product could create a situation where personal injury or death could occur.

No part of this publication may be reproduced, photocopied, stored on a retrieval system or transmitted without the express written consent of TDK-Micronas.

## TDK-Micronas Trademarks

– HAL

## Third-Party Trademarks

All other brand and product names or company names may be trademarks of their respective companies.

---

**Contents**

<b>Page</b>	<b>Section</b>	<b>Title</b>
<b>4</b>	<b>1.</b>	<b>Introduction</b>
5	1.1.	Features of HAL 15xy
<b>6</b>	<b>2.</b>	<b>Ordering Information</b>
6	2.1.	Device-Specific Ordering Codes
<b>8</b>	<b>3.</b>	<b>Functional Description of HAL 15xy</b>
9	3.1.	Functional Safety According to ISO 26262
9	3.1.1.	Diagnostic Features
9	3.2.	Power-On Self-Test
<b>11</b>	<b>4.</b>	<b>Specifications</b>
11	4.1.	Outline Dimensions
15	4.2.	Soldering, Welding and Assembly
15	4.3.	Pin Connections (from Top Side, example HAL 1502) and Short Descriptions
15	4.4.	Dimensions of Sensitive Area
16	4.5.	Absolute Maximum Ratings
17	4.6.	ESD and Latch-up
17	4.7.	Storage and Shelf Life
17	4.8.	Recommended Operating Conditions
18	4.9.	Characteristics
20	4.10.	HAL 1501 Magnetic Characteristics
22	4.11.	HAL 1502 Magnetic Characteristics
24	4.12.	HAL 1503 Magnetic Characteristics
26	4.13.	HAL 1504 Magnetic Characteristics
28	4.14.	HAL 1505 Magnetic Characteristics
30	4.15.	HAL 1506 Magnetic Characteristics
32	4.16.	HAL 1507 Magnetic Characteristics
34	4.17.	HAL 1508 Magnetic Characteristics
36	4.18.	HAL 1509 Magnetic Characteristics
38	4.19.	HAL 1510 Magnetic Characteristics
<b>40</b>	<b>5.</b>	<b>Application Notes</b>
40	5.1.	Application Circuits
41	5.1.1.	ESD System Level Application Circuit (ISO10605-2008)
41	5.2.	Ambient Temperature
42	5.3.	Start-Up Behavior
42	5.4.	EMC and ESD
<b>43</b>	<b>6.</b>	<b>Document History</b>

## Hall-Effect Switches with Open-Drain Output (3-Wire) in TO92 Package

---

**Release Note: Revision bars indicate significant changes to the previous edition.**

---

### 1. Introduction

The HAL 15xy Hall-switch family members produced in CMOS technology as 3-wire device with open-drain output transistor include a temperature-compensated Hall plate with active offset compensation, a comparator, and an output stage.

The comparator compares the actual magnetic flux through the Hall plate (Hall voltage) with the fixed reference values (switching points). Accordingly, the output transistor is switched on or off.

The active offset compensation leads to constant magnetic characteristics over supply voltage and temperature range. In addition, the magnetic parameters are robust against mechanical stress effects.

The sensors are designed for industrial and automotive applications and operate with supply voltages from 2.7 V to 24 V in the junction temperature range from  $-40\text{ }^{\circ}\text{C}$  up to  $170\text{ }^{\circ}\text{C}$ .

HAL 15xy is available in TO92UA leaded package.

## 1.1. Features of HAL 15xy

- TO92UA leaded package
- ISO 26262 compliant as ASIL B ready device
- Short-circuit protected open-drain output and thermal shutdown
- Low current consumption of typ. 1.6 mA
- Operates with supply voltages from 2.7 V to 24 V
- Overvoltage protection capability up to 40 V
- Reverse-voltage protected VSUP-pin (–18 V)
- High ESD performance of  $\pm 8$  kV (HBM)
- Diagnostic features: power-on self test
- Sample frequency of 500 kHz, 2  $\mu$ s output refresh time
- Operates with static and dynamic magnetic fields up to 12 kHz
- High resistance to mechanical stress by active offset compensation
- Constant switching points over a wide supply voltage and temperature range
- Wide junction temperature range from –40 °C to 170 °C
- Built-in temperature coefficient
- Optimized for applications in extreme automotive and industrial environments
- Qualified according to AEC-Q100 test standard for automotive electronics industry to provide high-quality performance
- Robust EMC performance, corresponding to different standards, such as ISO 7637, ISO 16750, IEC 61967, ISO 11452, and ISO 62132

## 2. Ordering Information

A Micronas device is available in a variety of delivery forms. They are distinguished by a specific ordering code:

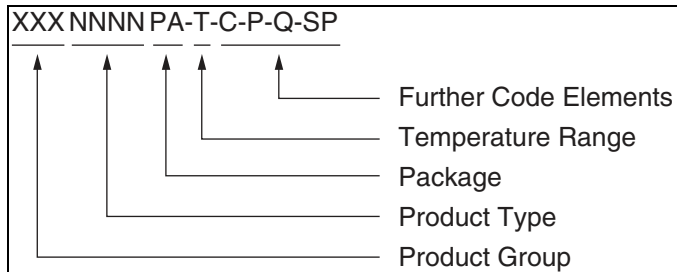

**Fig. 2–1:** Ordering Code Principle

For detailed information, please refer to the brochure: “Sensors and Controllers: Ordering Codes, Packaging, Handling”.

### 2.1. Device-Specific Ordering Codes

HAL 15xy is available in the following package and temperature range.

**Table 2–1:** Available packages

Package Code (PA)	Package Type
UA	TO92UA

**Table 2–2:** Available temperature ranges

Temperature Code (T)	Temperature Range
A	$T_J = -40\text{ °C to }170\text{ °C}$

The relationship between ambient temperature ( $T_A$ ) and junction temperature ( $T_J$ ) is explained in **Section 5.2. on page 41**.

For available variants for Configuration (C), Packaging (P), Quantity (Q) and Special Procedure (SP) please contact TDK-Micronas.

**Table 2–3:** Available ordering codes

Available Ordering Codes
HAL1501UA-A-[C-P-Q-SP]
HAL1502UA-A-[C-P-Q-SP]
HAL1503UA-A-[C-P-Q-SP]
HAL1504UA-A-[C-P-Q-SP]
HAL1505UA-A-[C-P-Q-SP]
HAL1506UA-A-[C-P-Q-SP]
HAL1507UA-A-[C-P-Q-SP]
HAL1508UA-A-[C-P-Q-SP]
HAL1509UA-A-[C-P-Q-SP]
HAL1510UA-A-[C-P-Q-SP]

This data sheet is valid for HAL 15xy derivatives with the product specific marking “3”, as shown in the example below.

**Table 2–4:** Example for Product Marking

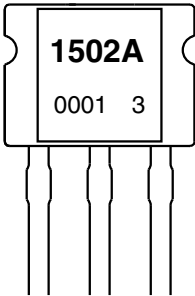
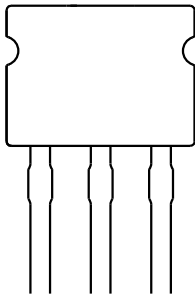
Package Top Surface Marking	Package Bottom Surface Marking
	
1502 = Product Typ A = Temperature Range 0001 = Date Code 3 = Product Specific Marking	No Marking

### 3. Functional Description of HAL 15xy

The HAL 15xy sensors are monolithic integrated circuits which switch in response to magnetic fields. If a magnetic field with flux lines perpendicular to the sensitive area is applied to the sensor, the biased Hall plate forces a Hall voltage proportional to this field. The Hall voltage is compared with the actual threshold level in the comparator. If the magnetic field exceeds the threshold levels, the output stage is switched to the appropriate state.

The built-in hysteresis eliminates oscillation and provides switching behavior of the output without bouncing.

Offsets caused by mechanical stress are compensated by using the “switching offset compensation technique”.

A diode on the supply line is not required thanks to the built-in reverse voltage protection.

The open drain output is forced to a safe, High-Z (high-impedance) state, in any of the following fault conditions: overtemperature and functional safety related diagnoses (see Section 3.1.). In addition, the output current is limited (short-circuit protection).

The device is able to withstand a maximum supply voltage of 24 V over lifetime and features overvoltage capability (40 V load dump).

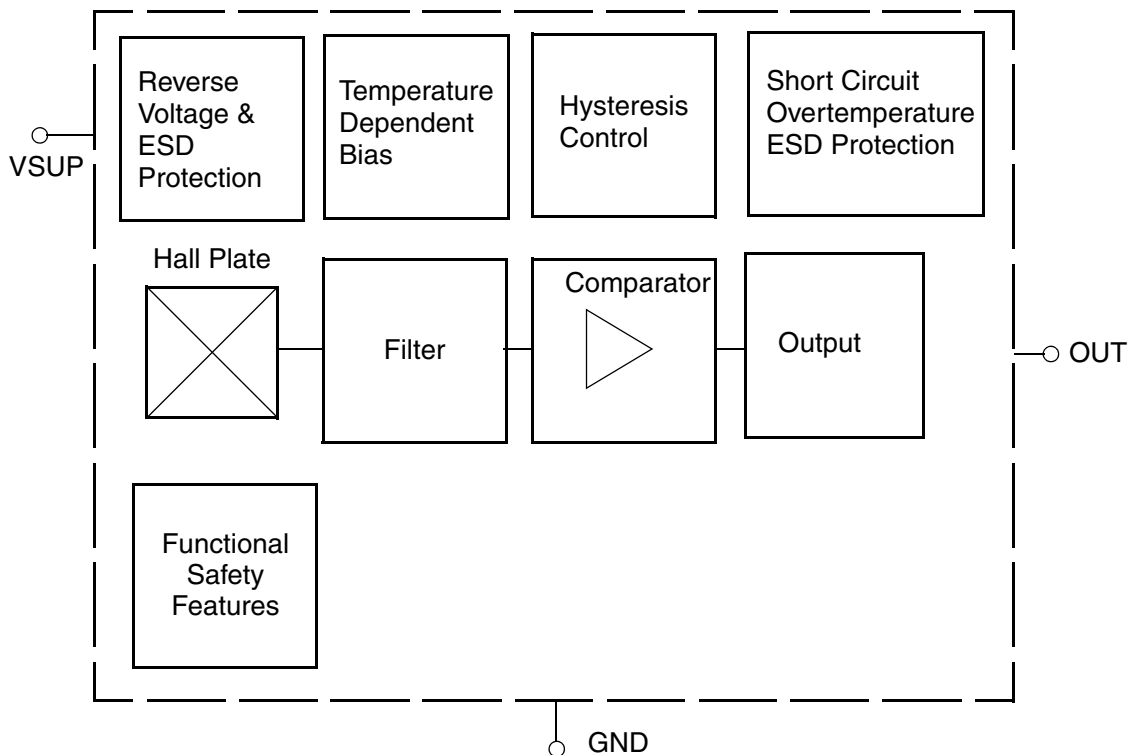

Fig. 3–1: HAL 15xy block diagram



---

## 3.1. Functional Safety According to ISO 26262

HAL 15xy is ISO 26262 compliant as an ASIL B ready device.

Magnetic and switching performance is defined as a hardware safety requirement.

The safe state is defined as High-Z output.

### 3.1.1. Diagnostic Features

Internal states are monitored and in an error condition flagged with a High-Z at the output:

- Internal voltage regulator: over voltage detection
- Monitoring of internal bias and current levels
- Monitoring of the internal reference voltage
- Monitoring of the Hall plate voltage

---

**Note** For further documentation regarding functional safety please contact TDK-Micronas.

---

## 3.2. Power-On Self-Test

The power-on self-test allows the customer to execute a functional check of the device, as well as to detect wire breaks as long as the host controls the power supply of the device.

In order to start the test, the host has to power on the sensor and to pull down its output pin to a logically zero level (below  $V_{OL\ max.}$ ) at least during the enable time ( $t_{en}$ ). Triggering of the power-on self-test is initiated when the output pin voltage exceeds the triggering voltage  $V_{OUTtrig}$  (see Section 4.8. on page 17). This order of events is the criteria for the sensor to start the power-on self-test.

The self-test can be enabled only once after power-on.

During the power-on self-test, the sensor simulates a magnetic field for a pre-defined period of time (see first observation window in Fig. 3–2), driving the sensor's output to Low-Z, detectable by the host.

Subsequently, the sensor simulates an opposite magnetic field during the second observation window (see Fig. 3–2), driving the sensor's output to High-Z, also detectable by the host. The described self-test behavior is not impacted by external magnetic fields up to about 300 mT.

After self-test completion, the sensor always returns to normal operation regardless of the test result.

---

**Note** In order to prevent an unintended triggering of the power-on self-test, the voltage at the OUT pin must exceed  $V_{OUTtrig}$  before the minimum enable time has elapsed.

---

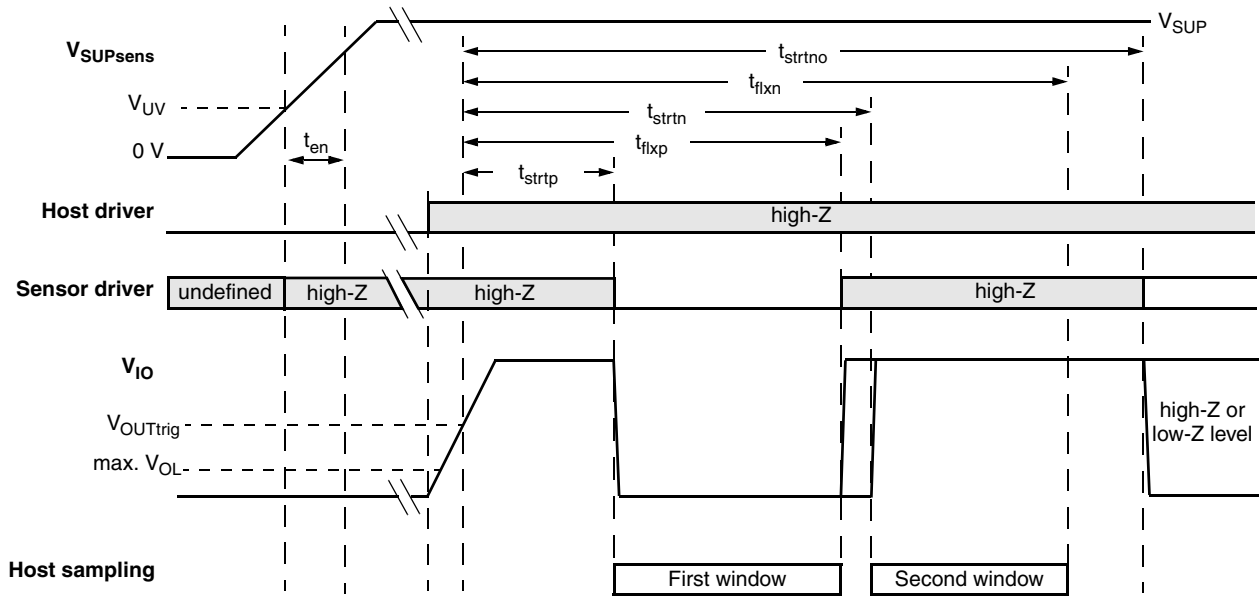

Fig. 3–2: Self-test timing diagram

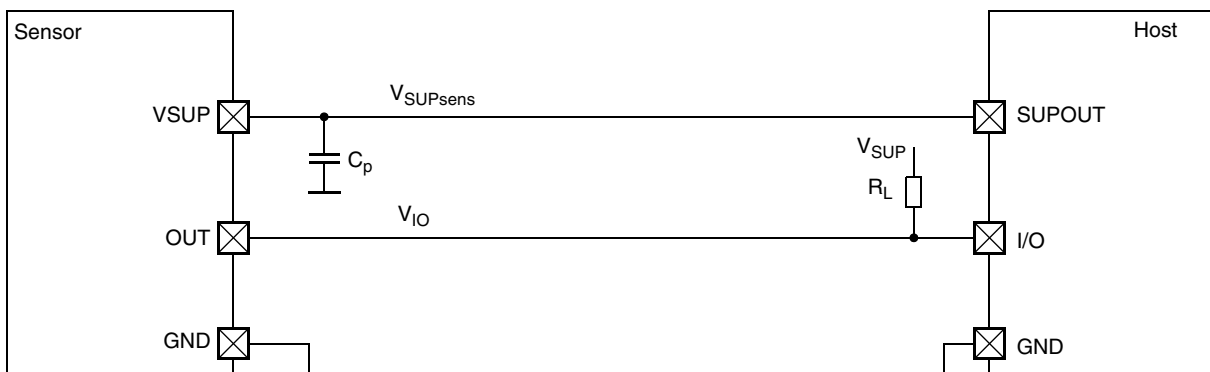
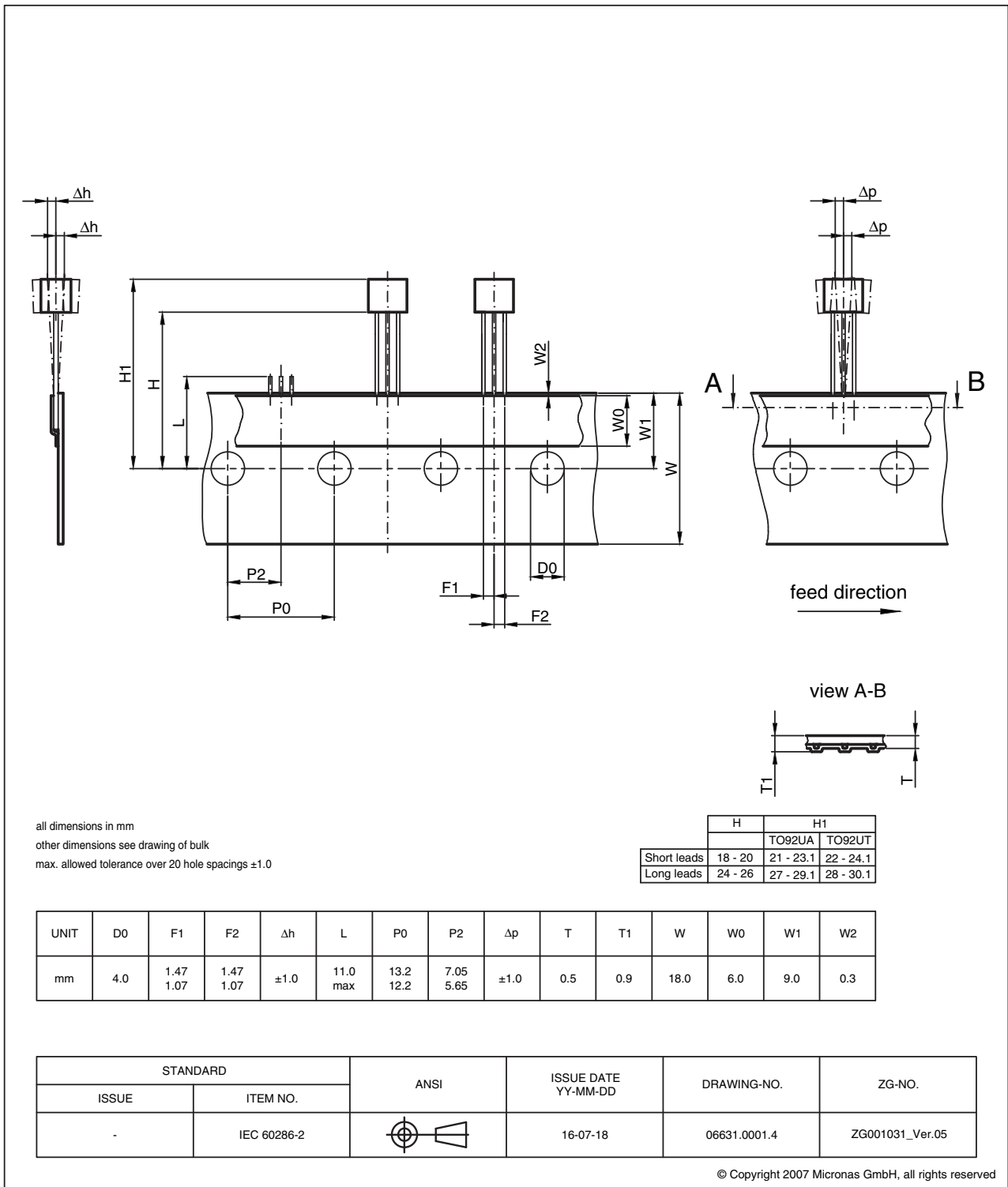
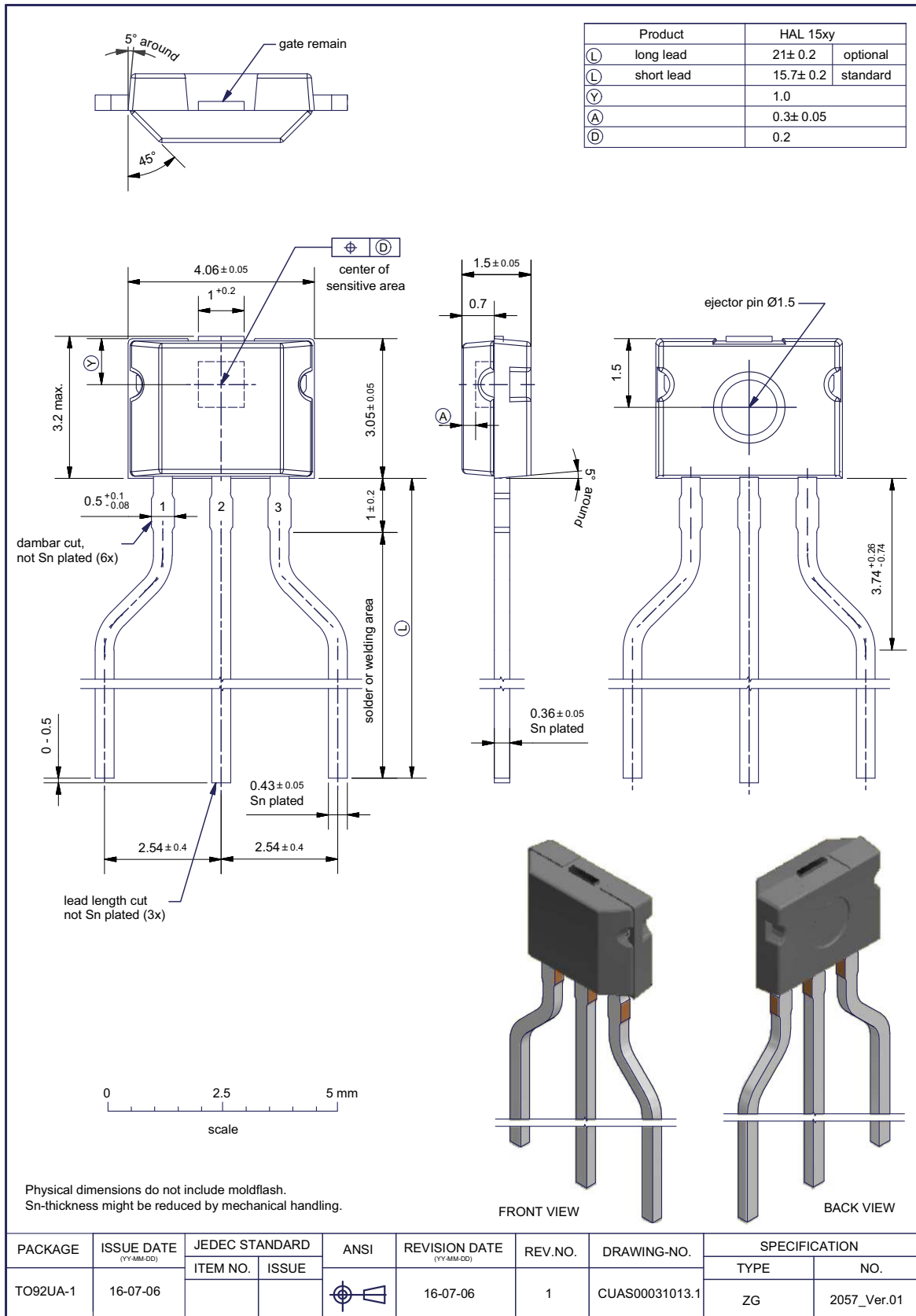

Fig. 3–3: External circuit diagram with switchable supply



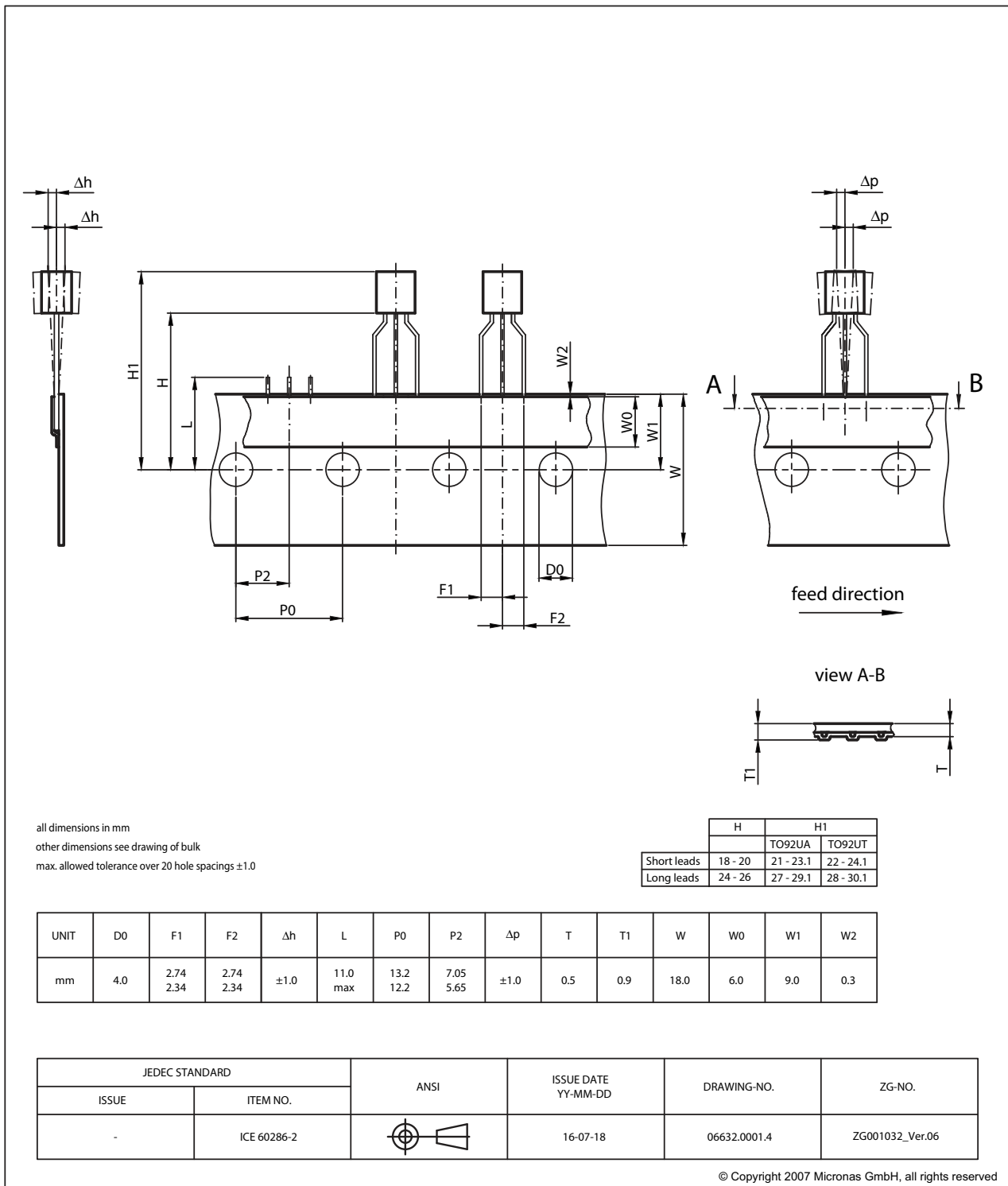

**Fig. 4–2:**  
 TO92UA/UT: Dimensions ammpack inline, non-spread



© Copyright 2016 Micronas GmbH, all rights reserved

**Fig. 4-3:**  
**TO92UA-1: Plastic Transistor Standard UA package, 3 leads, spread**  
Weight approximately 0.106 g



**Fig. 4-4:**  
**TO92UA/UT: Dimensions ammpack inline, spread**

## 4.2. Soldering, Welding and Assembly

Information related to solderability, welding, assembly, and second-level packaging is included in the document “Guidelines for the Assembly of Micronas Packages”.

It is available on the TDK-Micronas website (<http://www.micronas.com/en/service-center/downloads>) or on the service portal (<http://service.micronas.com>).

## 4.3. Pin Connections (from Top Side, example HAL 1502) and Short Descriptions

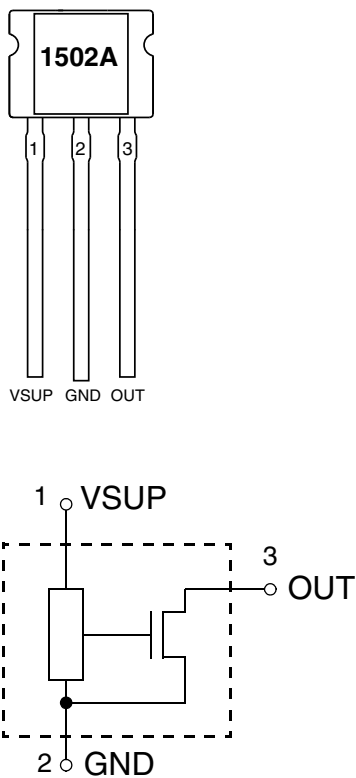

**Fig. 4–5:** Pin configuration

**Table 4–1:** Pin assignment.

Pin number	Name	Function
1	VSUP	Supply voltage
2	GND	Ground
3	OUT	Output

## 4.4. Dimensions of Sensitive Area

Parameter	Min.	Typ.	Max.	Unit
Dimension of sensitive area	–	100 x 100	–	$\mu\text{m}^2$

## 4.5. Absolute Maximum Ratings

Stresses beyond those listed in the “Absolute Maximum Ratings” may cause permanent damage to the device. This is a stress rating only. Functional operation of the device at these conditions is not implied. Exposure to absolute maximum rating conditions for extended periods will affect device reliability.

This device contains circuitry to protect the inputs and outputs against damage due to high static voltages or electric fields; however, it is advised that normal precaution must be taken to avoid application of any voltage higher than absolute maximum-rated voltages to this circuit.

All voltages listed are referenced to ground (GND).

Symbol	Parameter	Pin No	Min.	Max.	Unit	Conditions
$T_J$	Junction temperature range A	–	–40	190	°C	$t < 96 \text{ h}^{1)}$
$T_{\text{storage}}$	Transportation/Short-Term Storage Temperature	–	–55	150	°C	Device only without packing material
$V_{\text{SUP}}$	Supply voltage	1	–18	28	V	$t < 96 \text{ h}^{1)}$
			–	32	V	$t < 5 \text{ min}^{1)}$
			–	40	V	$t < 10 \times 400 \text{ ms}$ “Load-Dump” <sup>1)</sup> with series resistor $R_V > 100 \Omega$ .
$V_{\text{OUT}}$	Output voltage	3	–0.5	28	V	$t < 96 \text{ h}^{1)}$
$I_O$	Output current	3	–	65	mA	
$I_{\text{OR}}$	Reverse output current	3	–50	–	mA	
1) No cumulative stress						



## 4.6. ESD and Latch-up

The output pin has to be in High-Z for ESD measurements.

**Table 4–2:** ESD and latch-up

Symbol	Parameter	Min.	Max.	Unit
$I_{\text{latch}}$	Maximum latch-up free current at any pin (measurement according to AEC Q100-004), class 1	–100	100	mA
$V_{\text{HBM}}$	Human body model (according to AEC Q100-002)	–8	8	kV
$V_{\text{CDM}}$	Charged device model (according to AEC Q100-011)	–1	1	kV
$V_{\text{SYSTEM\_LEVEL}}$	Unpowered Gun Test (150 pF / 330 $\Omega$ or 330 pF / 2 k $\Omega$ ) according to ISO 10605-2008 <sup>1)</sup>	–15	15	kV

<sup>1)</sup> Only valid with ESD System Level Application Circuit (see Fig. 5–2 on page 41)

## 4.7. Storage and Shelf Life

Information related to storage conditions of Micronas sensors is included in the document “Guidelines for the Assembly of Micronas Packages”. It gives recommendations linked to moisture sensitivity level and long-term storage. It is available on the TDK-Micronas website (<http://www.micronas.com/en/service-center/downloads>) or on the service portal (<http://service.micronas.com>).

## 4.8. Recommended Operating Conditions

Functional operation of the device beyond those indicated in the “Recommended Operating Conditions” of this specification is not implied, may result in unpredictable behavior of the device, and may reduce reliability and lifetime.

All voltages listed are referenced to ground (GND).

Symbol	Parameter	Pin No.	Min.	Typ.	Max.	Unit	Conditions
$V_{\text{SUP}}$	Supply voltage	1	2.7	–	24	V	
$T_{\text{J}}$	Junction temperature range A <sup>1)</sup>	–	–40	–	170 150 125	°C	t < 1000 h <sup>2)</sup> t < 2500 h <sup>2)</sup> t < 8000 h <sup>2)</sup>
$V_{\text{OUT}}$	Output voltage	3	–	–	24	V	
$I_{\text{OUT}}$	Output current	3	–	–	25	mA	

<sup>1)</sup> Depends on the temperature profile of the application. Please contact TDK-Micronas for life time calculations.

<sup>2)</sup> No cumulative stress

## 4.9. Characteristics

at  $T_J = -40\text{ °C}$  to  $170\text{ °C}$ ,  $V_{SUP} = 2.7\text{ V}$  to  $24.0\text{ V}$ ,

at Recommended Operating Conditions if not otherwise specified in the column “Conditions”.

Typical Characteristics for  $T_J = 25\text{ °C}$  and  $V_{SUP} = 12.0\text{ V}$

Symbol	Parameter	Pin No.	Min.	Typ.	Max.	Unit	Conditions
<b>Supply</b>							
$V_{UV}$	Undervoltage threshold	1	2.0	–	2.7	V	
$I_{SUP}$	Supply current	1	1.1	1.6	2.4	mA	
$I_{SUPR}$	Reverse current	1	–1	–	–	mA	for $V_{SUP} = -18\text{ V}$
<b>Port Output</b>							
$V_{ol}$	Port low output voltage	3	–	0.13	0.4	V	$I_O = 20\text{ mA}$
			–	–	0.5	V	$I_O = 25\text{ mA}$
$I_{oleak}$	Output leakage current	3	–	0.1	10	$\mu\text{A}$	
$t_f$	Output fall time <sup>1)</sup>	3	–	–	1	$\mu\text{s}$	$V_{SUP} = 12\text{ V}$ $R_L = 820\ \Omega$ $C_L = 20\text{ pF}$
$t_r$	Output rise time <sup>1)</sup>	3	–	–	1	$\mu\text{s}$	
$B_{noise}$	Effective noise of magnetic switching points (RMS) <sup>2)</sup>	–	–	72	–	$\mu\text{T}$	For square wave signal with 12 kHz
$t_j$	Output jitter (RMS) <sup>1)</sup>	3	–	$\pm 0.58$	$\pm 0.72$	$\mu\text{s}$	For square wave signal with 1 kHz. Jitter is evenly distributed between $-1\ \mu\text{s}$ and $+1\ \mu\text{s}$
$t_d$	Delay time <sup>2) 3)</sup>	3	–	16	21	$\mu\text{s}$	
$t_{samp}$	Output refresh period <sup>2)</sup>	3	1.6	2.2	3.0	$\mu\text{s}$	
$t_{en}$	Enable time of output after exceeding of $V_{UV}$ <sup>4)</sup>	3	20	50	60	$\mu\text{s}$	$V_{SUP} = 12\text{ V}$ $B > B_{on} + 2\text{ mT}$ or $B < B_{off} - 2\text{ mT}$
<sup>1)</sup> Characterized on small sample size, not tested. <sup>2)</sup> Guaranteed by design <sup>3)</sup> Systematic delay between magnetic threshold reached and output switching <sup>4)</sup> If power-on self-test is executed, $t_{en}$ will be extended by power-on self-test period (see Section 3.2. on page 9)							

Symbol	Parameter	Pin No.	Min.	Typ.	Max.	Unit	Conditions
<b>Power-on Self-Test</b>							
$V_{OUTtrig}$	Triggering Voltage at output <sup>2)</sup>	3	1.7	–	–	V	
$t_{dsamp}$	Double sample period <sup>2)</sup>	–	3.2	4.4	6.0	$\mu$ s	
$t_{strtp}$	Start of first sampling window <sup>2)</sup>	–	–	–	4	$t_{dsamp}$	
$t_{flxp}$	End of first sampling window <sup>2)</sup>	–	9	–	–	$t_{dsamp}$	
$t_{strtn}$	Start of second sampling window <sup>2)</sup>	–	–	–	10	$t_{dsamp}$	
$t_{flxn}$	End of second sampling window <sup>2)</sup>	–	31	–	–	$t_{dsamp}$	
$t_{strtno}$	Start of first normal operation value <sup>2)</sup>	–	–	36.5	37	$t_{dsamp}$	
<b>Package</b>							
$R_{thja}$	Thermal Resistance junction to air	–	–	–	234	K/W	Determined with a 1s0p board
		–	–	–	180	K/W	Determined with a 1s1p board
		–	–	–	159	K/W	Determined with a 2s2p board
$R_{thjc}$	Thermal Resistance junction to case	–	–	–	58	K/W	Determined with a 1s0p board
		–	–	–	55	K/W	Determined with a 1s1p board
		–	–	–	53	K/W	Determined with a 2s2p board
<sup>2)</sup> Guaranteed by design							

## 4.10. HAL 1501 Magnetic Characteristics

The HAL 1501 bipolar Hall-switch provides highest sensitivity (see Fig. 4–6 on page 20).

The output turns to Low-Z with the magnetic south pole on the top side of the package and turns to High-Z with the magnetic north pole on the top side. The output state is not defined if the magnetic field is removed again.

For correct functioning in the application, the sensor requires both magnetic polarities (north and south) on the top side of the package.

### Magnetic Features:

- switching type: bipolar
- very high sensitivity
- typical  $B_{ON}$ : 0.4 mT at room temperature
- typical  $B_{OFF}$ : –0.4 mT at room temperature
- operates with static magnetic fields and dynamic magnetic fields up to 12 kHz
- typical temperature coefficient of magnetic switching points is 0 ppm/K at room temperature

### Applications

The HAL 1501 is the optimal sensor for all applications with alternating magnetic signals and weak magnetic amplitude at the sensor position such as:

- applications with large air gap or weak magnets
- revolutions per minute (RPM) or other counting measurement, e.g. window lifter and sunroof
- commutation of brushless DC motors
- position detection, such as for gear-shift lever and electric parking brake
- magnetic encoders

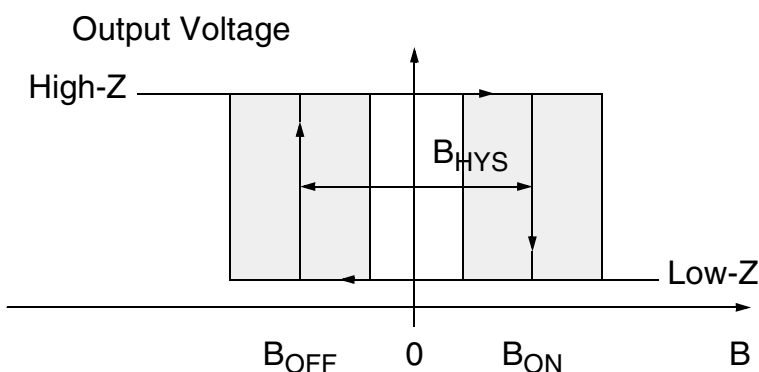

**Fig. 4–6:** Definition of magnetic switching points for the HAL 1501

## Magnetic Characteristics

at  $T_J = -40\text{ °C}$  to  $170\text{ °C}$ ,  $V_{SUP} = 2.7\text{ V}$  to  $24.0\text{ V}$ ,  
 Typical Characteristics for  $V_{SUP} = 12.0\text{ V}$

Magnetic flux density values of switching points:

Positive flux density values refer to the magnetic south pole at the top side of the package.

Parameter $T_J$	On point $B_{ON}$			Off point $B_{OFF}$			Hysteresis $B_{HYS}$			Unit
	Min.	Typ.	Max.	Min.	Typ.	Max.	Min.	Typ.	Max.	
$-40\text{ °C}$	-0.6	0.5	1.6	-1.6	-0.5	0.6	-	1.0	-	mT
$25\text{ °C}$	-0.5	0.4	1.5	-1.5	-0.4	0.5	-	0.8	-	mT
$170\text{ °C}$	-1.0	0.35	2.0	-2.0	-0.35	1.0	-	0.7	-	mT

The hysteresis is the difference between the switching points  $B_{HYS} = |B_{ON} - B_{OFF}|$

**Note** Regarding switching points, temperature coefficients, and B-field switching frequency, customized derivatives via mask option are possible. For more information contact TDK-Micronas.

## 4.11. HAL 1502 Magnetic Characteristics

The HAL 1502 Hall-latch provides highest sensitivity (see Fig. 4–7 on page 22).

The output turns to Low-Z with the magnetic south pole on the top side of the package and turns to High-Z with the magnetic north pole on the top side. The output does not change if the magnetic field is removed. For changing the output state, the opposite magnetic field polarity must be applied.

For correct functioning in the application, the sensor requires both magnetic polarities (north and south) on the top side of the package.

### Magnetic Features:

- switching type: latching
- high sensitivity
- typical  $B_{ON}$ : 2.5 mT at room temperature
- typical  $B_{OFF}$ : –2.5 mT at room temperature
- operates with static magnetic fields and dynamic magnetic fields up to 12 kHz
- typical temperature coefficient of magnetic switching points is –1000 ppm/K at room temperature

### Applications

The HAL 1502 is the optimal sensor for all applications with alternating magnetic signals and weak magnetic amplitude at the sensor position such as:

- applications with large air gap or weak magnets
- revolutions per minute (RPM) or other counting measurement, e.g. window lifter and sunroof
- commutation of brushless DC motors
- position detection, such as for adaptive front lighting and electric parking brake
- magnetic encoders

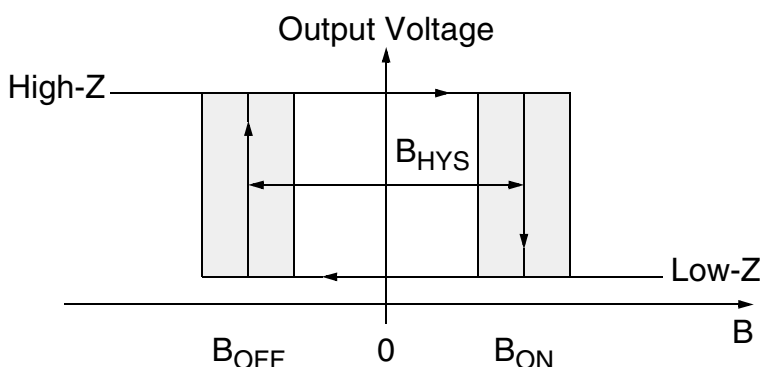

**Fig. 4–7:** Definition of magnetic switching points for the HAL 1502

## Magnetic Characteristics

at  $T_J = -40\text{ °C}$  to  $170\text{ °C}$ ,  $V_{SUP} = 2.7\text{ V}$  to  $24.0\text{ V}$ ,  
 Typical Characteristics for  $V_{SUP} = 12.0\text{ V}$

Magnetic flux density values of switching points:

Positive flux density values refer to the magnetic south pole at the top side of the package.

Parameter $T_J$	On point $B_{ON}$			Off point $B_{OFF}$			Hysteresis $B_{HYS}$			Unit
	Min.	Typ.	Max.	Min.	Typ.	Max.	Min.	Typ.	Max.	
$-40\text{ °C}$	1.3	2.8	4.3	-4.3	-2.8	-1.3	–	5.6	–	mT
$25\text{ °C}$	1.0	2.5	4.0	-4.0	-2.5	-1.0	–	5.0	–	mT
$170\text{ °C}$	0.8	2.3	3.8	-3.8	-2.3	-0.8	–	4.6	–	mT

The hysteresis is the difference between the switching points  $B_{HYS} = |B_{ON} - B_{OFF}|$

**Note** Regarding switching points, temperature coefficients and B-field switching frequency, customized derivatives via mask option are possible. For more information contact TDK-Micronas.

## 4.12. HAL 1503 Magnetic Characteristics

The HAL 1503 unipolar Hall-switch provides high sensitivity (see Fig. 4–8 on page 24).

The output turns to Low-Z with the magnetic south pole on the top side of the package and turns to High-Z if the magnetic field is removed. The sensor does not respond to the magnetic north pole on the top side of the package.

For correct functioning in the application, the sensor requires only the magnetic south pole on the top side of the package.

### Magnetic Features:

- switching type: unipolar
- high sensitivity
- typical  $B_{ON}$ : 5.5 mT at room temperature
- typical  $B_{OFF}$ : 3.7 mT at room temperature
- operates with static magnetic fields and dynamic magnetic fields up to 12 kHz
- typical temperature coefficient of magnetic switching points is  $-1000$  ppm/K at room temperature

### Applications

The HAL 1503 is the optimal sensor for all applications with one magnetic polarity and weak magnetic amplitude at the sensor position, such as:

- clutch position detection
- electric parking brake
- brake light switch
- brake pedal position detection
- steering wheel lock
- door handle

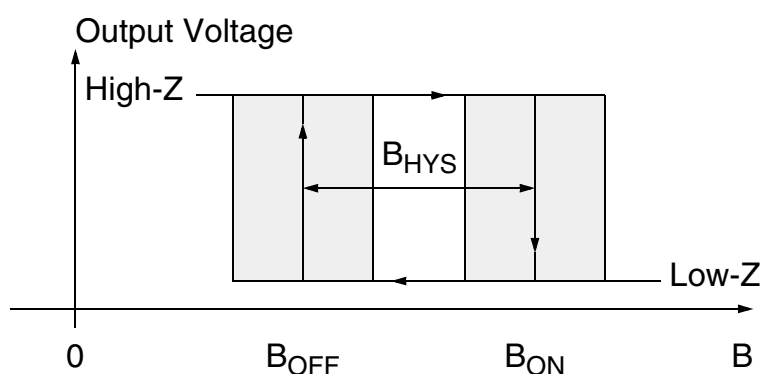

**Fig. 4–8:** Definition of magnetic switching points for the HAL 1503



## Magnetic Characteristics

at  $T_J = -40\text{ °C}$  to  $170\text{ °C}$ ,  $V_{SUP} = 2.7\text{ V}$  to  $24.0\text{ V}$ ,  
 Typical Characteristics for  $V_{SUP} = 12.0\text{ V}$

Magnetic flux density values of switching points:

Positive flux density values refer to the magnetic south pole at the top side of the package.

Parameter $T_J$	On point $B_{ON}$			Off point $B_{OFF}$			Hysteresis $B_{HYS}$			Unit
	Min.	Typ.	Max.	Min.	Typ.	Max.	Min.	Typ.	Max.	
$-40\text{ °C}$	4.4	6.1	7.6	2.4	4.0	5.7	–	2.1	–	mT
$25\text{ °C}$	3.8	5.5	7.1	2.1	3.7	5.5	–	1.8	–	mT
$170\text{ °C}$	3.0	5.0	6.7	1.8	3.6	5.5	–	1.4	–	mT

The hysteresis is the difference between the switching points  $B_{HYS} = |B_{ON} - B_{OFF}|$

**Note** Regarding switching points, temperature coefficients and B-field switching frequency, customized derivatives via mask option are possible. For more information contact TDK-Micronas.

### 4.13. HAL 1504 Magnetic Characteristics

The HAL 1504 Hall latch provides high sensitivity (see Fig. on page 26).

The output turns to Low-Z with the magnetic south pole on the top side of the package and turns to High-Z with the magnetic north pole on the top side. The output does not change if the magnetic field is removed. For changing the output state, the opposite magnetic field polarity must be applied.

For correct functioning in the application, the sensor requires both magnetic polarities (north and south) on the top side of the package.

#### Magnetic Features:

- switching type: latching
- high sensitivity
- typical B<sub>ON</sub>: 7.6 mT at room temperature
- typical B<sub>OFF</sub>: –7.6 mT at room temperature
- operates with static magnetic fields and dynamic magnetic fields up to 12 kHz
- typical temperature coefficient of magnetic switching points is –1200 ppm/K at room temperature

#### Applications

The HAL 1504 is the optimal sensor for all applications with alternating magnetic signals such as:

- applications with large air gap or weak magnets
- revolutions per minute (RPM) or other counting measurement, e.g. window lifter and sunroof
- commutation of brushless DC motors
- position detection, such as for gear-shift lever and electric parking brake
- magnetic encoders

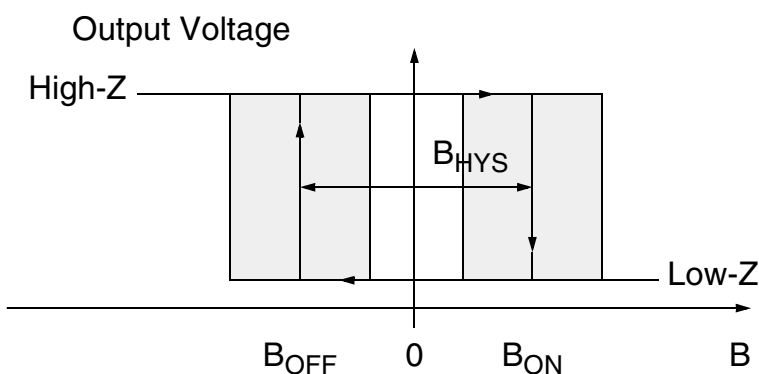

**Fig. 4–9:** Definition of magnetic switching points for the HAL 1504

## Magnetic Characteristics

at  $T_J = -40\text{ °C}$  to  $170\text{ °C}$ ,  $V_{SUP} = 2.7\text{ V}$  to  $24.0\text{ V}$ ,  
 Typical Characteristics for  $V_{SUP} = 12.0\text{ V}$

Magnetic flux density values of switching points:

Positive flux density values refer to the magnetic south pole at the top side of the package.

Parameter $T_J$	On point $B_{ON}$			Off point $B_{OFF}$			Hysteresis $B_{HYS}$			Unit
	Min.	Typ.	Max.	Min.	Typ.	Max.	Min.	Typ.	Max.	
$-40\text{ °C}$	6.4	8.4	10.8	-10.8	-8.6	-6.4	–	17.0	–	mT
$25\text{ °C}$	6.0	7.6	10.0	-10	-7.6	-6.0	–	15.2	–	mT
$170\text{ °C}$	4.0	6.4	8.9	-8.9	-6.4	-4.0	–	12.8	–	mT

The hysteresis is the difference between the switching points  $B_{HYS} = | B_{ON} - B_{OFF} |$

**Note** Regarding switching points, temperature coefficients, and B-field switching frequency, customized derivatives via mask option are possible. For more information contact TDK-Micronas.

#### 4.14. HAL 1505 Magnetic Characteristics

The HAL 1505 Hall-latch provides medium sensitivity (see Fig. 4–10 on page 28).

The output turns to Low-Z with the magnetic south pole on the top side of the package and turns to High-Z with the magnetic north pole on the top side. The output does not change if the magnetic field is removed. For changing the output state, the opposite magnetic field polarity must be applied.

For correct functioning in the application, the sensor requires both magnetic polarities (north and south) on the top side of the package.

##### Magnetic Features:

- switching type: latching
- medium sensitivity
- typical B<sub>ON</sub>: 13.5 mT at room temperature
- typical B<sub>OFF</sub>: –13.5 mT at room temperature
- operates with static magnetic fields and dynamic magnetic fields up to 12 kHz
- typical temperature coefficient of magnetic switching points is –1200 ppm/K at room temperature

##### Applications

The HAL 1505 is the optimal sensor for all applications with alternating magnetic signals such as:

- applications with large air gap or weak magnets
- revolutions per minute (RPM) or other counting measurement, e.g. window lifter and sunroof
- commutation of brushless DC motors
- position detection, such as for adaptive front lighting and electric parking brake
- magnetic encoders

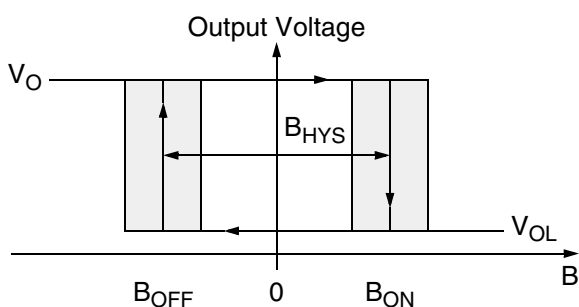

**Fig. 4–10:** Definition of magnetic switching points for the HAL 1505

## Magnetic Characteristics

at  $T_J = -40\text{ °C}$  to  $170\text{ °C}$ ,  $V_{SUP} = 2.7\text{ V}$  to  $24.0\text{ V}$ ,  
 Typical Characteristics for  $V_{SUP} = 12.0\text{ V}$

Magnetic flux density values of switching points:

Positive flux density values refer to the magnetic south pole at the top side of the package.

Parameter $T_J$	On point $B_{ON}$			Off point $B_{OFF}$			Hysteresis $B_{HYS}$			Unit
	Min.	Typ.	Max.	Min.	Typ.	Max.	Min.	Typ.	Max.	
$-40\text{ °C}$	11.8	15.0	18.3	-18.3	-15.0	-11.8	–	30.0	–	mT
$25\text{ °C}$	11.0	13.5	17.0	-17.0	-13.5	-11.0	–	27.0	–	mT
$170\text{ °C}$	9.4	11.7	16.1	-16.1	-11.7	-9.4	–	23.4	–	mT

The hysteresis is the difference between the switching points  $B_{HYS} = |B_{ON} - B_{OFF}|$

### Note

Regarding switching points, temperature coefficients, and B-field switching frequency, customized derivatives via mask option are possible. For more information contact TDK-Micronas.

## 4.15. HAL 1506 Magnetic Characteristics

The HAL 1506 unipolar Hall-switch provides medium sensitivity (see Fig. 4–11 on page 30).

The output turns to Low-Z with the magnetic south pole on the top side of the package and turns to High-Z if the magnetic field is removed. The sensor does not respond to the magnetic north pole on the top side of the package.

For correct functioning in the application, the sensor requires only the magnetic south pole on the top side of the package.

### Magnetic Features:

- switching type: unipolar
- medium sensitivity
- typical  $B_{ON}$ : 18.9 mT at room temperature
- typical  $B_{OFF}$ : 17.3 mT at room temperature
- operates with static magnetic fields and dynamic magnetic fields up to 12 kHz
- typical temperature coefficient of magnetic switching points is  $-1200$  ppm/K at room temperature

### Applications

The HAL 1506 is the optimal sensor for applications with one magnetic polarity, such as:

- clutch pedal position
- wiper position
- door lock
- trunk lock

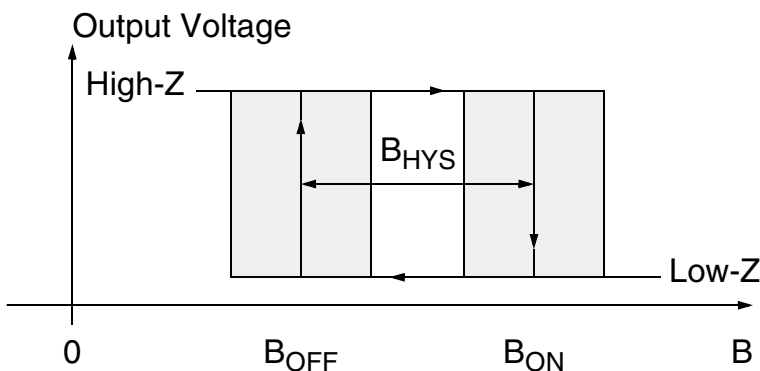

**Fig. 4–11:** Definition of magnetic switching points for the HAL 1506

## Magnetic Characteristics

at  $T_J = -40\text{ °C}$  to  $170\text{ °C}$ ,  $V_{SUP} = 2.7\text{ V}$  to  $24.0\text{ V}$ ,  
 Typical Characteristics for  $V_{SUP} = 12.0\text{ V}$

Magnetic flux density values of switching points:

Positive flux density values refer to the magnetic south pole at the top side of the package.

Parameter $T_J$	On point $B_{ON}$			Off point $B_{OFF}$			Hysteresis $B_{HYS}$			Unit
	Min.	Typ.	Max.	Min.	Typ.	Max.	Min.	Typ.	Max.	
$-40\text{ °C}$	16.5	20.8	24.8	14.0	18.9	22.5	–	1.9	–	mT
$25\text{ °C}$	15.4	18.9	22.6	13.8	17.3	21.0	–	1.6	–	mT
$170\text{ °C}$	13.0	17.0	19.5	11.8	15.8	18.2	–	1.2	–	mT

The hysteresis is the difference between the switching points  $B_{HYS} = |B_{ON} - B_{OFF}|$

**Note** Regarding switching points, temperature coefficients and B-field switching frequency, customized derivatives via mask option are possible. For more information contact TDK-Micronas.

## 4.16. HAL 1507 Magnetic Characteristics

The HAL 1507 unipolar Hall-switch provides low sensitivity (see Fig. 4–12 on page 32).

The output turns to Low-Z with the magnetic south pole on the top side of the package and turns to High-Z if the magnetic field is removed. The sensor does not respond to the magnetic north pole on the top side of the package.

For correct functioning in the application, the sensor requires only the magnetic south pole on the top side of the package.

### Magnetic Features:

- switching type: unipolar
- low sensitivity
- typical  $B_{ON}$ : 28.2 mT at room temperature
- typical  $B_{OFF}$ : 23.9 mT at room temperature
- operates with static magnetic fields and dynamic magnetic fields up to 12 kHz
- typical temperature coefficient of magnetic switching points is  $-300$  ppm/K at room temperature

### Applications

The HAL 1507 is the optimal sensor for applications with one magnetic polarity and strong magnetic fields at the sensor position, such as:

- gear position detection
- rooftop open/close
- sliding door

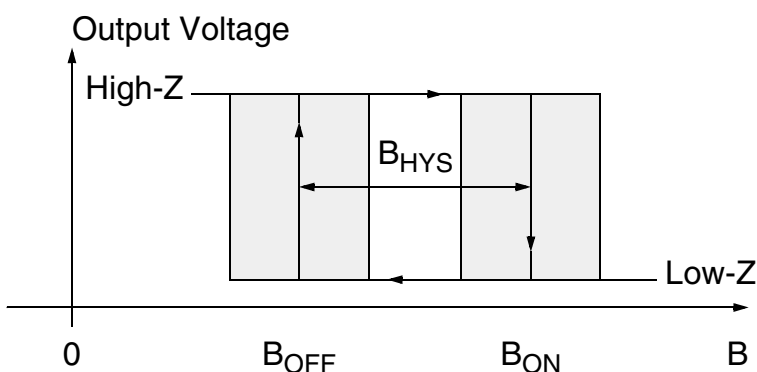

**Fig. 4–12:** Definition of magnetic switching points for the HAL 1507



## Magnetic Characteristics

at  $T_J = -40\text{ °C}$  to  $170\text{ °C}$ ,  $V_{SUP} = 2.7\text{ V}$  to  $24\text{ V}$ ,  
 Typical Characteristics for  $V_{SUP} = 12.0\text{ V}$

Magnetic flux density values of switching points:

Positive flux density values refer to the magnetic south pole at the top side of the package.

Parameter $T_J$	On point $B_{ON}$			Off point $B_{OFF}$			Hysteresis $B_{HYS}$			Unit
	Min.	Typ.	Max.	Min.	Typ.	Max.	Min.	Typ.	Max.	
$-40\text{ °C}$	24.0	29.5	35.0	18.7	24.7	30.7	–	4.8	–	mT
$25\text{ °C}$	23.7	28.2	32.7	19.0	23.9	28.8	–	4.3	–	mT
$170\text{ °C}$	22.5	27.7	32.9	18.6	23.9	29.2	–	3.8	–	mT

The hysteresis is the difference between the switching points  $B_{HYS} = |B_{ON} - B_{OFF}|$

**Note** Regarding switching points, temperature coefficients, and B-field switching frequency, customized derivatives via mask option are possible. For more information contact TDK-Micronas.

## 4.17. HAL 1508 Magnetic Characteristics

The HAL 1508 unipolar Hall-switch provides high sensitivity (see Fig. 4–13 on page 34).

The output turns to Low-Z with the magnetic north pole on the top side of the package and turns to High-Z if the magnetic field is removed. The sensor does not respond to the magnetic south pole.

For correct functioning in the application, the sensor requires only the magnetic north pole on the top side of the package.

### Magnetic Features:

- switching type: unipolar
- high sensitivity
- typical  $B_{ON}$ : –5.5 mT at room temperature
- typical  $B_{OFF}$ : –3.7 mT at room temperature
- operates with static magnetic fields and dynamic magnetic fields up to 12 kHz
- typical temperature coefficient of magnetic switching points is –1000 ppm/K at room temperature

### Applications

The HAL 1508 is the optimal sensor for all applications with one magnetic polarity and weak magnetic amplitude at the sensor position. In combination with HAL 1503 it is often used for clutch pedal position detection, for instance. Other examples are:

- electric parking brake
- wiper position
- door lock

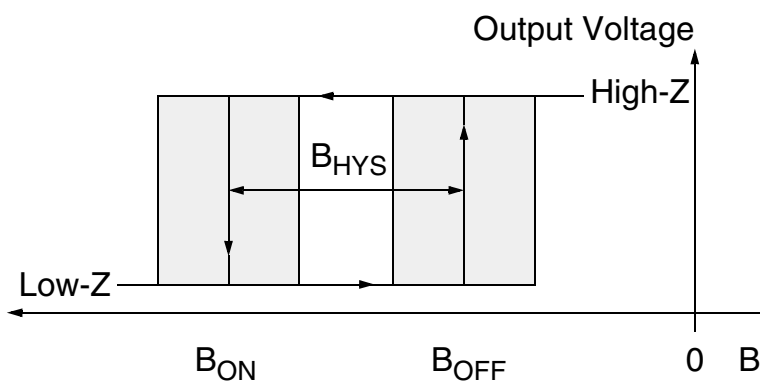

**Fig. 4–13:** Definition of magnetic switching points for the HAL 1508

## Magnetic Characteristics

at  $T_J = -40\text{ °C}$  to  $170\text{ °C}$ ,  $V_{SUP} = 2.7\text{ V}$  to  $24\text{ V}$ ,  
 Typical Characteristics for  $V_{SUP} = 12.0\text{ V}$

Magnetic flux density values of switching points:

Positive flux density values refer to the magnetic south pole at the top side of the package.

Parameter $T_J$	On point $B_{ON}$			Off point $B_{OFF}$			Hysteresis $B_{HYS}$			Unit
	Min.	Typ.	Max.	Min.	Typ.	Max.	Min.	Typ.	Max.	
$-40\text{ °C}$	-7.6	-6.1	-4.4	-5.7	-4.0	-2.4	-	2.1	-	mT
$25\text{ °C}$	-7.1	-5.5	-3.8	-5.5	-3.7	-2.1	-	1.8	-	mT
$170\text{ °C}$	-6.7	-5.0	-3.0	-5.5	-3.6	-1.8	-	1.4	-	mT

The hysteresis is the difference between the switching points  $B_{HYS} = |B_{ON} - B_{OFF}|$

**Note** Regarding switching points, temperature coefficients, and B-field switching frequency, customized derivatives via mask option are possible. For more information contact TDK-Micronas.

## 4.18. HAL 1509 Magnetic Characteristics

The HAL 1509 unipolar inverted Hall-switch provides high sensitivity (see Fig. 4–14 on page 36).

The output turns to High-Z with the magnetic south pole on the top side of the package and turns to Low-Z if the magnetic field is removed. The sensor does not respond to the magnetic north pole on the top side of the package.

For correct functioning in the application, the sensor requires only the magnetic south pole on the top side of the package.

### Magnetic Features:

- switching type: unipolar inverted
- high sensitivity
- typical  $B_{ON}$ : 3.7 mT at room temperature
- typical  $B_{OFF}$ : 5.5 mT at room temperature
- operates with static magnetic fields and dynamic magnetic fields up to 12 kHz
- typical temperature coefficient of magnetic switching points is  $-1000$  ppm/K at room temperature

### Applications

The HAL 1509 is the optimal sensor for all applications with one magnetic polarity and weak magnetic amplitude at the sensor position where an inverted output signal is required, such as:

- electric valve actuation
- door lock
- brake position detection

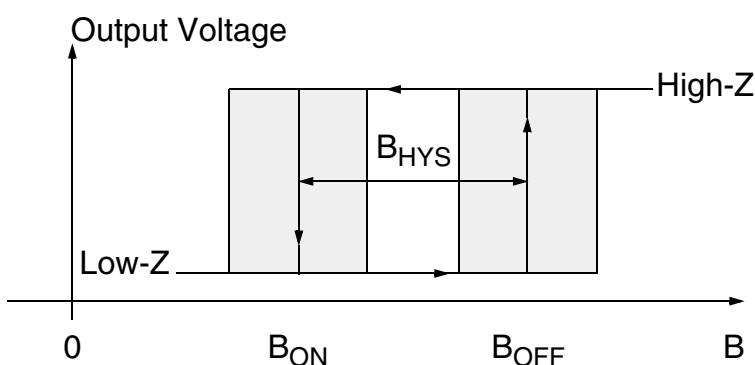

**Fig. 4–14:** Definition of magnetic switching points for the HAL 1509

## Magnetic Characteristics

at  $T_J = -40\text{ °C}$  to  $170\text{ °C}$ ,  $V_{SUP} = 2.7\text{ V}$  to  $24\text{ V}$ ,  
 Typical Characteristics for  $V_{SUP} = 12.0\text{ V}$

Magnetic flux density values of switching points:

Positive flux density values refer to the magnetic south pole at the top side of the package.

Parameter $T_J$	On point $B_{ON}$			Off point $B_{OFF}$			Hysteresis $B_{HYS}$			Unit
	Min.	Typ.	Max.	Min.	Typ.	Max.	Min.	Typ.	Max.	
$-40\text{ °C}$	2.4	4.0	5.7	4.4	6.1	7.6	–	2.1	–	mT
$25\text{ °C}$	2.1	3.7	5.5	3.8	5.5	7.1	–	1.8	–	mT
$170\text{ °C}$	1.8	3.6	5.5	3.0	5.0	6.7	–	1.4	–	mT

The hysteresis is the difference between the switching points  $B_{HYS} = |B_{ON} - B_{OFF}|$

**Note** Regarding switching points, temperature coefficients, and B-field switching frequency, customized derivatives via mask option are possible. For more information contact TDK-Micronas.

## 4.19. HAL 1510 Magnetic Characteristics

The HAL 1510 unipolar Hall switch provides medium sensitivity (see Fig. 4–15 on page 38).

The output turns to Low-Z with the magnetic south pole on the top side of the package and turns to High-Z if the magnetic field is removed. The sensor does not respond to the magnetic north pole on the top side of the package.

For correct functioning in the application, the sensor requires only the magnetic south pole on the top side of the package.

### Magnetic Features:

- switching type: unipolar
- medium sensitivity
- typical  $B_{ON}$ : 12.0 mT at room temperature
- typical  $B_{OFF}$ : 7.0 mT at room temperature
- operates with static magnetic fields and dynamic magnetic fields up to 12 kHz
- typical temperature coefficient of magnetic switching points is  $-1200$  ppm/K at room temperature

### Applications

The HAL 1510 is the optimal sensor for all applications with one magnetic polarity, such as:

- clutch position detection
- electric parking brake
- brake light switch
- brake pedal position detection
- steering wheel lock
- door handle

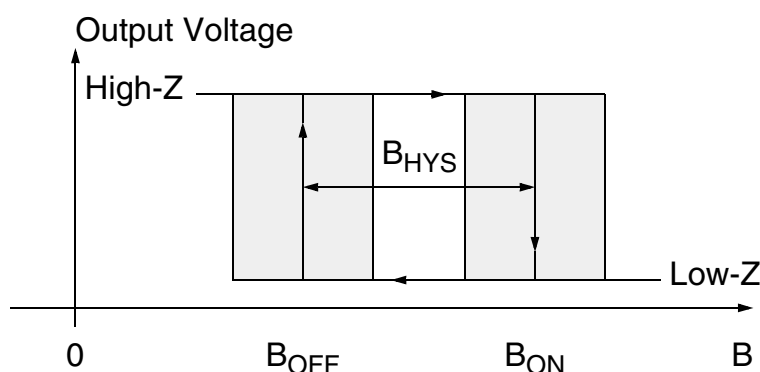

**Fig. 4–15:** Definition of magnetic switching points for the HAL 1510

## Magnetic Characteristics

at  $T_J = -40\text{ °C}$  to  $170\text{ °C}$ ,  $V_{SUP} = 2.7\text{ V}$  to  $24.0\text{ V}$ ,  
 Typical Characteristics for  $V_{SUP} = 12.0\text{ V}$

Magnetic flux density values of switching points:

Positive flux density values refer to the magnetic south pole at the top side of the package.

Parameter $T_J$	On point $B_{ON}$			Off point $B_{OFF}$			Hysteresis $B_{HYS}$			Unit
	Min.	Typ.	Max.	Min.	Typ.	Max.	Min.	Typ.	Max.	
$-40\text{ °C}$	10.3	13.0	16.0	5.3	7.5	10.0	–	5.5	–	mT
$25\text{ °C}$	9.5	12.0	14.5	5.0	7.0	9.0	–	5.0	–	mT
$170\text{ °C}$	8.5	10.2	13.7	4.2	5.9	8.5	–	4.3	–	mT

The hysteresis is the difference between the switching points  $B_{HYS} = | B_{ON} - B_{OFF} |$

**Note** Regarding switching points, temperature coefficients, and B-field switching frequency, customized derivatives via mask option are possible. For more information contact TDK-Micronas.

## 5. Application Notes

### 5.1. Application Circuits

For applications with disturbances on the supply line or radiated disturbances, a series resistor  $R_V$  and two capacitors  $C_P$  and  $C_L$  all placed close to the sensor are recommended (see Fig. 5–1).

For example:  $R_V = 100 \Omega$ ,  $C_P = 10 \text{ nF}$ , and  $C_L = 4.7 \text{ nF}$ .

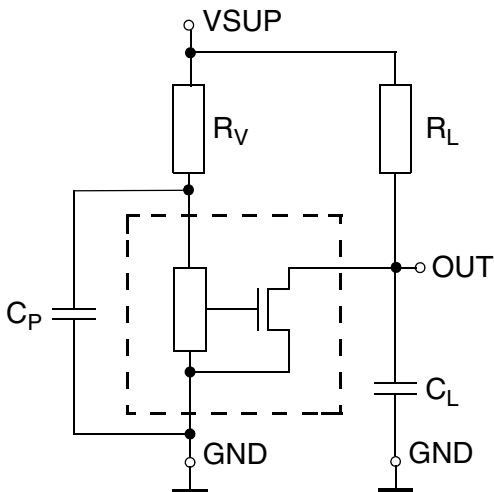

**Fig. 5–1:** Example for a recommended application circuit

$R_L$  is the open-drain pull-up resistor and has to be placed close to the input of the host controller to enable wire-break detection.



### 5.1.1. ESD System Level Application Circuit (ISO10605-2008)

For an ESD system level application circuit according to ISO10605-2008 a 100 nF capacitor at VSUP and an additional TVS diode at OUT are necessary.

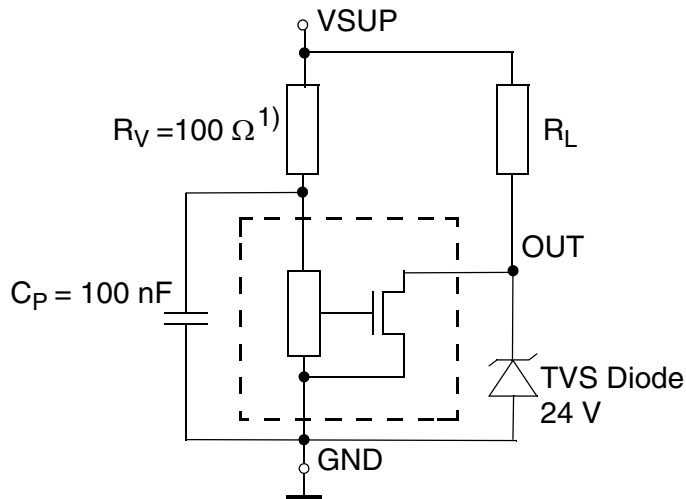

<sup>1)</sup> required for 40 V load dump capability

**Fig. 5–2:** Application circuit with external resistor

## 5.2. Ambient Temperature

Due to the internal power dissipation, the temperature on the silicon chip (junction temperature  $T_J$ ) is higher than the temperature outside the package (ambient temperature  $T_A$ ).

$$T_J = T_A + \Delta T$$

Under static conditions and continuous operation, the following equation applies:

$$\Delta T = (I_{SUP} \times V_{SUP} \times R_{thja}) + (I_{OUT} \times V_{OUT} \times R_{thja})$$

For all sensors, the junction temperature range  $T_J$  is specified. The maximum ambient temperature  $T_{Amax}$  can be calculated as:

$$T_{Amax} = T_{Jmax} - \Delta T$$

For typical values, use the typical parameters. For worst case calculation, use the max. parameters for  $I_{SUP}$ ,  $I_{OUT}$ , and  $R_{thja}$ , and the max. value for  $V_{OUT}$  and  $V_{SUP}$  from the application.

### 5.3. Start-Up Behavior

For supply voltages below the undervoltage threshold  $V_{UV}$  the output is undefined. After exceeding  $V_{UV}$ , the sensor has an enable time ( $t_{en}$ ). During the enable time, the output state is defined as High-Z.

After  $t_{en}$ , the output will be Low-Z if the applied magnetic field  $B$  is above  $B_{ON}$ . The output will be High-Z if  $B$  is below  $B_{OFF}$ . In case of sensors with an inverted switching behavior, the output state will be High-Z if  $B > B_{OFF}$  and Low-Z if  $B < B_{ON}$ .

After  $t_{en}$  and magnetic fields between  $B_{OFF}$  and  $B_{ON}$ , the output state of the HAL 15xy sensor will be either High-Z or Low-Z. Any transition of magnetic switching points above  $B_{ON}$ , respectively, below  $B_{OFF}$  will switch to the corresponding output state.

### 5.4. EMC and ESD

For applications with disturbances on the supply line or radiated disturbances, a series resistor and a capacitor are recommended. The series resistor and the capacitor should be placed as close as possible to the HAL sensor.

Special application arrangements were evaluated to pass EMC tests according to different standards, such as ISO 7637, ISO 16750, IEC 61967, ISO 11452 and ISO 62132.

## 6. Document History

1. Data Sheet: "HAL 150y, Hall-Effect Switches with Open-Drain Output (3-Wire) in TO92 Package", March 12, 2018; DSH000196\_001EN. First release of the data sheet.
2. Data Sheet: "HAL 15xy, Hall-Effect Switches with Open-Drain Output (3-Wire) in TO92 Package", Oct. 8, 2018; DSH000196\_002EN. Second release of the data sheet.

Major Changes:

- Information of product derivatives HAL 1504, HAL 1505 and HAL 1510 added
- According to this, the document name changed from HAL 150y to HAL 15xy
- Section 4.9. 'Characteristics': pin numbers added

3. Data Sheet: "HAL 15xy, Hall-Effect Switches with Open-Drain Output (3-Wire) in TO92 Package", March 30, 2022; DSH000196\_003EN. Third release of the data sheet.

Major Changes:

- ASIL A to ASIL B changed