

5

4

3

2

1

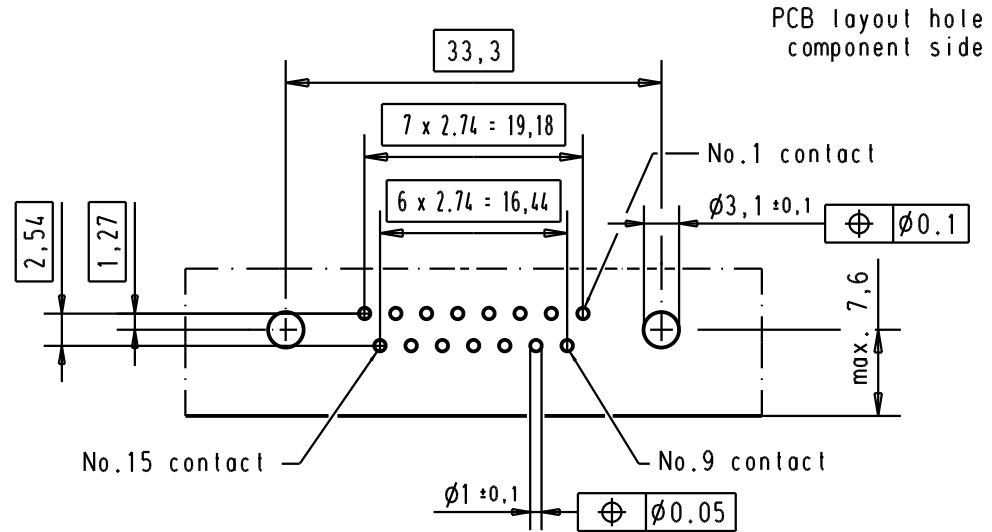
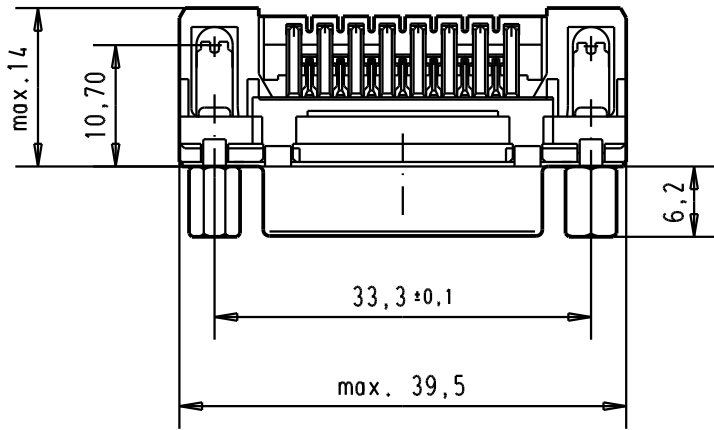
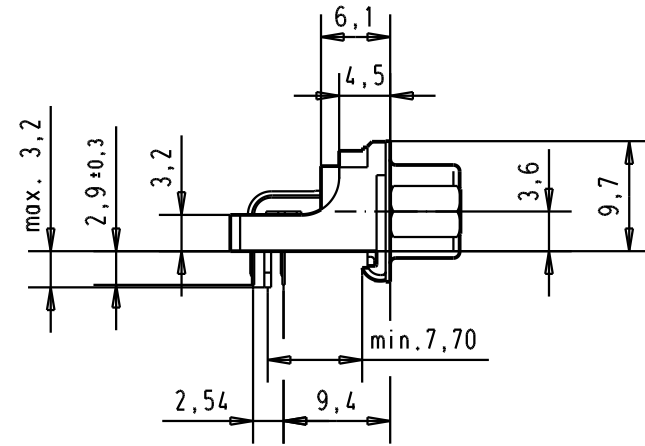
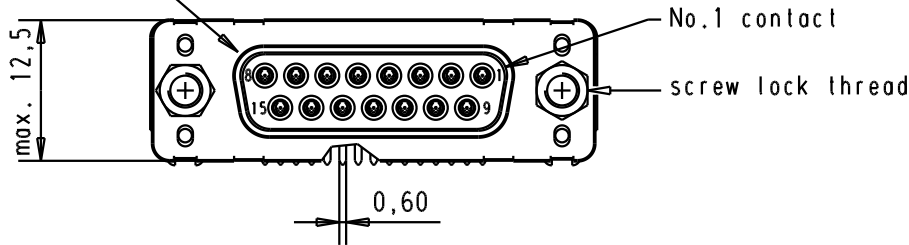

Mating face according to : MIL-C-24308 / DIN 41652 / CECC 75301-802



PCB layout hole component side

Connector retention and insertion forces on the PCB = 25 / 80 newtons

A

			31892	05/05/04	JH	Detail.	02/sept/00	jfb	 <p>All Dim. in mm Orig. Size DIN A 4</p>	D-Sub 15 poles low profil angle female, solder pin with screw lock and grounding board lock.	Maßstab/ Scale 1.5:1		
			31084	04/SEP/02	YT	Insp.							
09 66 252 3617	4-40 UNC	1	27961	24/nov/00	jfb	Stand.							
09 66 252 6617	4-40 UNC	2	27952	26/oct/00	jfb	HARTING EURL F-95972 Paris				TB 0966252x61x	Blatt/ Page 3 / 5		
09 66 252 7617	4-40 UNC	3	27948	02/sept/00	jfb								
Part number	Screw lock thread	Performance level	Mod.	Dat.	Name				Sub.				