

FAA-PMA

REVISIONS		RELEASED	
SYM	DESCRIPTION	DATE	APPROVED
T	22490 REDRAWN TO CAEDS FILE NO CHANGE	93/01/06	WS
U	24147 ADD FIND 17-19: FIND 1 P/N WAS 001	93/06/28	WS
V	35443 NOTE 2 ADDED	98/05/04	RS
W	0438-03 RELOCATED BALLOON 17	03/04/28	CC
Y	11-022329 ADDED VENT "LOCATION OPTIONAL"	10/08/27	CB

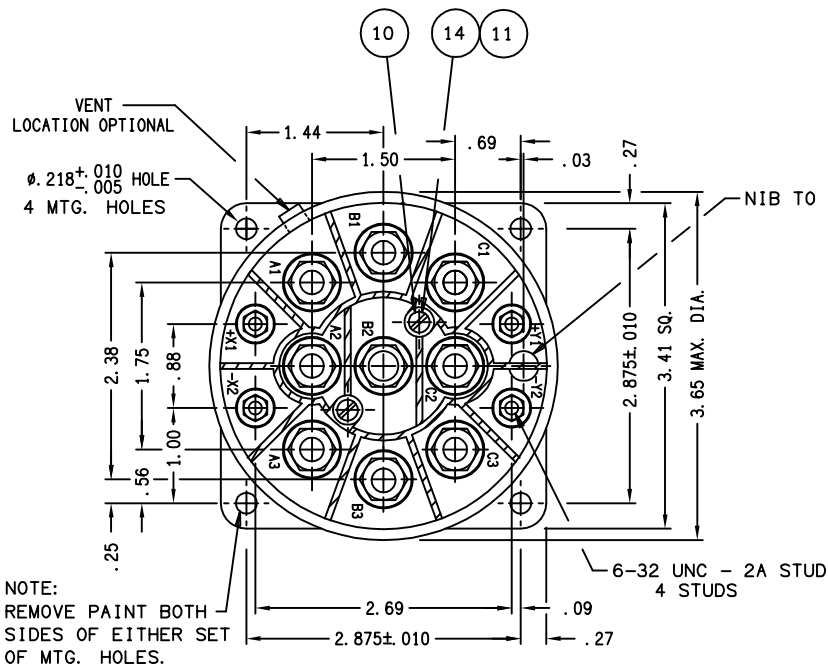

NOTE:
REMOVE PAINT BOTH
SIDES OF EITHER SET
OF MTG. HOLES.

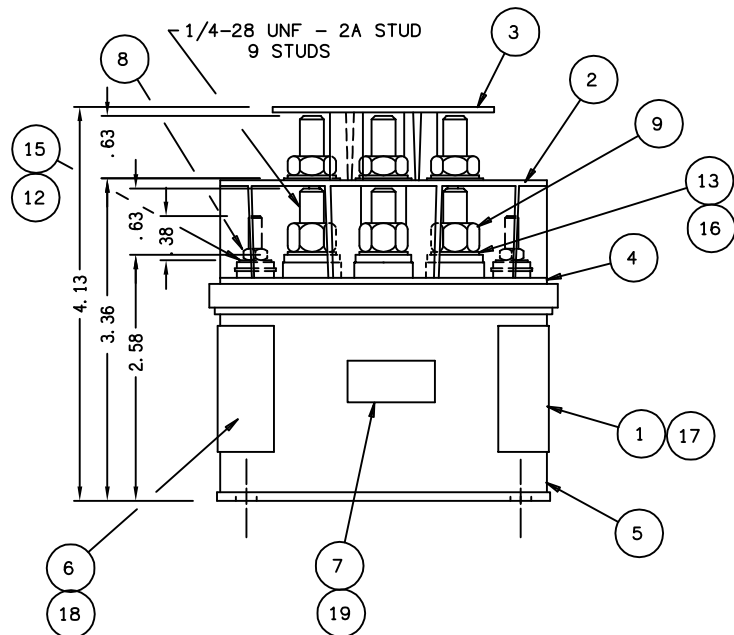

CONSTRUCTION CONTACTS
 NOMINAL CONTACT VOLTAGE 115/200V, 400 HZ
 MAIN CONTACT CONFIGURATION 3PDT CENTER OFF
 RATING: RESISTIVE 100 AMP, 400HZ
 NOMINAL COIL VOLTAGE 28 VDC
 PICKUP VOLTAGE 18 VDC MAX (HOT)
 DROPOUT VOLTAGE 7 +0
 -5.5 VDC
 TEMPERATURE RANGE -55°C TO +71°C
 MIN. OPERATING CYCLES 50,000
 MAX. WEIGHT 2 LBS. 5OZ.
 MAX. INTERRUPTING CAPACITY 10 TIMES RATED
 COIL RES. -EACH 160Ω ±20%
 PICKUP TIME .040 SEC. AT 28 VDC
 DROPOUT TIME .020 SEC. AT 28 VDC
 BOUNCE TIME .002 SEC.

GASKET SEALED

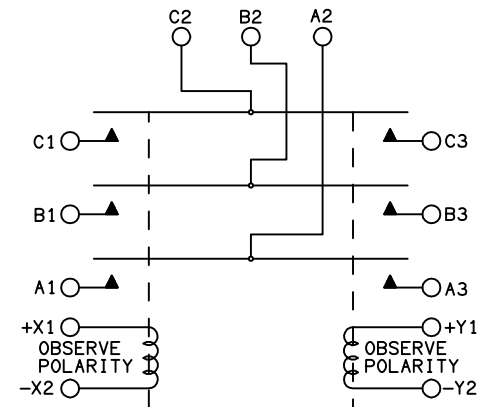

NOTES:
 1. ALL UNITS STARTING WITH S/N CD 43103A AND IDENTIFIED WITH THE LETTER "A" AFTER THE SERIAL NUMBER HAVE 160 OHM COILS.
 2. FAA/PMA PLATE (AND OVERLAY) NOT REQUIRED ON UNITS SUPPLIED TO ORIGINAL EQUIPMENT MANUFACTURERS.

19	1	39529-017	OVERLAY			
18	1	39529-009	OVERLAY			
17	1	39529-023	OVERLAY			
16	9	51807-034	WASHER-LOCK NO.1/4 SPLIT	MS 35338-101	BRONZE	
15	4	51806-014	WASHER-LOCK NO.6 SPLIT	MS 35338-98	BRONZE	
14	2	51805-011	WASHER-LOCK NO.5 SPLIT	AN935B5L	BRONZE	
13	9	51703-064	WASHER-FLAT 1/2X17/64X.032	AN960B416	BRASS	
12	4	51702-204	WASHER-FLAT 3/8X9/64X.032	AN960B-6	BRASS	
11	2	51701-180	WASHER, .015X.103X3/16		FISHPAPER	
10	2	51205-411	SCREW, 5-40X1 3/8 RD. HD.		STEEL	
9	9	50407-074	NUT, 1/4-28 X 3/8 X 3/16HEX.		BRASS	
8	4	50406-034	NUT, 6-32 X 1/4 X 5/64 HEX.	MS35649-265	BRASS	
7	1	58400-037	PLATE-FAA/PMA			
6	1	20397-001	PLATE-WIRING DIAGRAM			
5	1	20074-030	CONTACTOR ASSEMBLY PRI.			
4	1	17542-008	PLATE - BASE COVER			
3	1	17540-001	SHIELD - TERMINAL, TOP ZYTEL			
2	1	17539-001	SHIELD - TERMINAL ZYTEL			
1	1	16043-063	PLATE - NAME			

FIND NO	QTY REQD	PART OR IDENTIFYING NO	NOMENCLATURE OR DESCRIPTION	FSCM NO	DRAWING OR SPECIFICATION	MATERIAL OR NOTE
---------	----------	------------------------	-----------------------------	---------	--------------------------	------------------

UNLESS OTHERWISE SPECIFIED DIMENSIONS ARE IN INCHES TOLERANCES ON

2 PL DEC.	3 PL DEC.	ANGLES
±.06	±.010	± 1°

MATERIAL

DR BY	CSC	03/05/14
CHK BY	CC	03/05/14
ENGR	EJV	03/05/14
MFG	MH	03/05/14
SIZE	CODE IDENT	
C	74063	
SCALE	NONE	SHEET

TE
Hartman™ Division, 175 N. DIAMOND STREET MANSFIELD, OHIO 44902

CONTACTOR - 3PDT CENTER OFF
28 VDC COILS 093

DWG NO. D-31C

REF TE P/N 1616049-1